

TECHNICAL MANUAL

**OPERATOR'S, ORGANIZATION,
DIRECT SUPPORT AND GENERAL
SUPPORT MAINTENANCE MANUAL
FPR**

**SIGNAL GENERATOR AN/USM-47
(NSN 6625-00-445-6917)**

**This copy is a reprint which includes current
pages from Changes 1.**

HEADQUARTERS, DEPARTMENT OF THE ARMY

OCTOBER 1978

WARNING
DANGEROUS VOLTAGES
EXIST IN THIS EQUIPMENT

Voltages as high as -1250 volts exist inside the cabinet. Be careful when signal generator is removed from cabinet.

DON'T TAKE CHANCES!

CHANGE }
No. 1 }

TM 11-6625-2910-14
C1
HEADQUARTERS
DEPARTMENT OF THE ARMY
WASHINGTON, DC 23 November 1979

**Operator's, Organizational, Direct Support,
and General Support Maintenance Manual
for
SIGNAL GENERATOR AN/USM-47
(NSN 6625-00-445-6917)**

TM 11-6625-2910-14, 2 October 1978, is changed as follows:

1. New or changed material is indicated by a vertical bar in the margin of the page.
2. Remove and insert pages as indicated in the page list below:

<i>Remove</i>	<i>Insert</i>
i and ii.....	i and ii
0-1 and 1-0	0-1 and 1-0
A-1	A-1(A-2 blank)
B-1 and B-2	B-1 and B-2

3. File this change sheet in the front of the publication for reference purposes.

By Order of the Secretary of the Army:

Official:

E. C. MEYER
*General, United States Army
Chief of Staff*

J. C. PENNINGTON
*Major General, United States Army
The Adjutant General*

DISTRIBUTION:

Active Army

TSG (1)	USAERDAA (1)
USAARENBD (1)	USAERDAW (1)
USAINSCOM (2)	Army Dep (1) except
TRADOC (2)	LBAD (10)
DARCOM (1)	SAAD (30)
TECOM (2)	TOAD (14)
OS Maj Comd (2)	SHAD (3)
HISA (Ft Monmouth) (21)	USA Dep (1)
USACC (2)	Sig Sec USA Dep (1)
Armies (1)	Units org under fol TOE:
Svc Colleges (1)	29-134 (1)
USASIGS (10)	29-136 (1)
Ft Richardson (CERCOM Ofc) (1)	29-207 (2)
Ft Carson (5)	29-610 (2)
Ft Gillem (10)	32-52 (1)
WSMR (1)	32-57 (1)

NG: State AG (0); Units - (0)
USAR: (0)

For explanation of abbreviations used, see AR 310-50.

TECHNICAL MANUAL
NO. 11 - 6625 - 2910 -14



HEADQUARTERS
DEPARTMENT OF THE ARMY
WASHINGTON, DC, 2 October 1978

**OPERATOR'S, ORGANIZATIONAL, DIRECT SUPPORT,
AND GENERAL SUPPORT MAINTENANCE MANUAL
FOR**

**SIGNAL GENERATOR AN/USM-47
(NSN 6625-00-445-6917)**

REPORTING OF ERRORS

You can improve this manual by recommending improvements using DA Form 2028-2 located in the back of the manual. Simply tear out the self-addressed form, fill it out as shown on the sample, fold it where shown, and drop it in the mail.

If there are no blank DA Forms 20282 in the back of your manual, use the standard DA Form 2028 (Recommended Changes to Publications and Blank Forms) and forward to the Commander, US Army Communications and Electronics Materiel Readiness Command, ATTN: DRSEL-ME-MQ, Fort Monmouth, NJ 07703.

In either case a reply will be furnished direct to you.

	Page
O. INTRODUCTION	O-1
I. GENERAL INFORMATION	1-1
1-1. Description	1-1
1-6. Accessories Furnished	1-2
1-8. Accessories Available	1-2
1-10. Instrument Identification	1-2
II. INSTALLATION	2-1
2-1. Inspection	2-1
2-4. Air Filter	2-1
2-6. Power Requirements	2-1
2-8. Power Cable	2-1
2-11. 230-Volt Operation	2-1
2-13. Repackaging for Shipment	2-1
III. OPERATING INSTRUCTIONS	3-1
3-1. Introduction	3-1
3-3. Harmonics	3-1
3-6. Operating Procedure	3-1
3-9. CW Output	3-1
3-10. Square-Wave Output	3-1
3-11. Internal Pulse Modulation	3-1
3-12. External Pulse Modulation	3-1
3-13. Internal FM at Line Frequency	3-1
3-15. External FM	3-2
IV. PRINCIPLES OF OPERATION	4-1
4-1. Introduction	4-1
4-3. Pulse Section	4-1
4-5. Input Amplifier and Pulse Rate Multivibrator	4-1
4-10. Schmitt Trigger	4-3
4-17. Sync Out Thyatron 43	4-3
4-19. Delay Multivibrator	4-3
4-27. Delayed Sync Out Thyatron	4-4
4-29. Pulse Width Multivibrator	4-4

	Page
4-33. Modulator Section	4-5
4-36. RF Oscillator Section	4-6
4-38. Reflex Klystron Operation	4-7
4-45. RF Oscillator Tube	4-7
4-50. Power-Monitor Section	4-9
4-54. Output Attenuator Section	4-10
SECTION V. MAINTENANCE	5-1
5-1. Introduction	5-1
5-3. Cleaning the Air Filter	5-1
5-5. Test Equipment	5-1
5-7. Troubleshooting	5-1
5-8. Locating Trouble	5-1
5-11. Troubleshooting Charts	5-1
5-14. Power Supply	5-1
5-22. Repair	5-3
5-23. Cabinet Removal	5-3
5-25. Tube Replacement Chart	5-3
5-27. Servicing Etched Circuit Boards	5-3
5-29. Klystron Tube Replacement	5-5
5-36. Reflector Potentiometer Replacement	5-8
5-38. Replacing RT1	5-10
5-40. Adjustments	5-11
5-41. Zero Set Control Adjustment	5-11
5-43. Schmitt Trigger Level Adjustment	5-11
5-45. Adjustments Following Klystron Replacement	5-11
5-54. Calibration	5-18
5-55. Calibrating Pulse Rate Dial	5-18
5-57. Calibrating Pulse Delay Dial	5-19
5-58. Calibrating Pulse Width Dial	5-19
5-59. Power-Monitor Meter Calibration	5-19
5-62. Performance Checks	5-20
5-64. Frequency Calibration Check	5-20
5-65. Output Power Check	5-20
VI. REPLACEABLEPARTS	6-1
6-1. Introduction	6-1
6-4. Ordering Information	6-1
APPENDIX A. REFERENCES	A-1
APPENDIX B. COMPONENTS OF END ITEM LIST	
SECTION I. Introduction	B-1
II. Integral Components of End Item	B-2
III. Basic Issue Items	B-3
APPENDIX C. ADDITIONAL AUTHORIZATION LIST (Not Applicable)	
APPENDIX D. MAINTENANCE ALLOCATION	
SECTION I. Introduction	D-1
II. Maintenance Allocation Chart for Signal Generator AN/USM-47	D-3
III. Tool and Test Equipment Requirement for Signal Generator AN/USM-47	D-4
IV. Remarks	D-5
APPENDIX E. EXPENDABLE SUPPLIES AND MATERIALS LIST (Not Applicable)	
APPENDIX F. CODE LIST OF MANUFACTURERS	F-1
APPENDIX G. BACKDATING MODEL 626A	G-1
APPENDIX H. MANUALCHANGES	H-1
APPENDIX I. ILLUSTRATED PARTS IDENTIFICATION	I-1

LIST OF ILLUSTRATIONS

Number	Title	Page	Number	Title	Page
1-1.	(Model 626A SHF Signal Generator.....	1-0	5-10.	Top View Showing Location of Reflector Tracking Pots.	5-13
1-2.	Klystron Tube Warranty	1-2	5-11.	Test Setup for Observing Reflector Modes.....	5-14
3-1.	Operating Controls and Connectors	3-0	5-12.	Typical Mode Patterns	5-15
4-1.	Timing Sequence in Pulse Section.....	4-1	5-13.	Adjustment of Mode Suppressors and Output Matching Screw	5-16
4-2.	Block Diagram	4-2	5-14.	Calibration Test Setup.....	5-17
4-3.	Block Diagram of Pulse Section		5-15.	Typical Pulse and Square Wave Oscillograms.....	5-18
	Showing Waveforms	4-2	5-16.	Test Setup for Adjusting Output Power.....	5-19
4-4.	Input Amplifier and Pulse Rate.....		5-17.	Power Supply, V & R Diagram.....	5-22
	Multivibrator	4-3	5-18.	Power Supply, Schematic Diagram.....	5-23
4-5.	Schmitt Trigger and Sync Out Thyatron.....	4-3	5-19.	Pulse Section, V & R Diagram	5-24
4-6.	Delay Multivibrator	4-4	5-20.	Pulse Generator, Schematic Diagram	5-25
4-7.	Waveform Comparison	4-4	5-21.	Modulator and RF Generator Sections, V& R Diagram.....	5-26
4-8.	Delay Multivibrator Grid and Plate Waveforms	4-4	5-22.	Modulator and RF Generator, Schematic Diagram	5-27
4-9.	Delayed Sync Out Thyatron and Pulse Width Multivibrator	4-5			
4-10.	Modulator V18 and MOD SELECTOR Switch S3	4-5		ILLUSTRATED PARTS IDENTIFICATION	
4-11.	RF Oscillator and Waveguide System	4-6	1.	HP Model 626A, S. H. F. Signal Generator, General Arrangement.....	2
4-12.	Bunching of Electrons in a Reflex Klystron	4-7	2.	HP Model 626A, S. H. F. Signal Generator, Control Panel, Front View	4
4-13.	Equivalent Circuits of RF Oscillator	4-8	3.	HP Model 626A, S. H. F. Signal Generator, Control Panel, Rear View	6
4-14.	Graph Showing Klystron Oscillation Modes	4-9	4.	HP Model 626A, S. H. F. Signal Generator, Frequency Drive Assembly,	8
4-15.	Power-Monitor Section	4-9	5.	HP Model 626A, S. H. F. Signal Generator, Cavity Assembly	10
4-16.	Phantom View Showing Output Attenuator	4-10	6.	HP Model 626A, S. H. F. Signal Generator, Directional Coupler Assembly	12
5-1.	Block Diagram of Power Supply.....	5-3	7.	HP Model 626A, S. H. F. Signal Generator, Attenuator Assembly	14
5-2.	Rear View of Instrument Showing Power Supply and Pulse Sections.....	5-4	8.	HP Model 626A, S. H. F. Signal Generator, Chassis Front View.....	16
5-3.	View of Klystron Cavity and Frequency Drive Mechanism	5-7	9.	HP Model 626A, S. H. F. Signal Generator, Chassis, Rear View	18
5-4.	Cutaway Views of Klystron Cavity.....	5-9	10.	HP Model 626A, S. H. F. Signal Generator, Cabinet	20
5-5.	Exploded View of Klystron Cavity and Plunger Drive Mechanism.....	5-10			
5-6.	Detail Showing Reflector Potentiometer Removal	5-10			
5-7.	Right Side View Showing Power Monitoring Bridge Adjustments.....	5-11			
5-8.	Test Setup for Schmitt Trigger Level Adjustment	5-12			
5-9.	Graph Showing Reflector Tracking Voltage vs Frequency	5-12			

LIST OF TABLES

Number	Title	Page	Number	Title	Page
1-1.	Specifications	1-0	5-4.	Pulse Section Troubleshooting	5-5
5-2.	Power Supply Troubleshooting.....	5-2	5-5.	Tube Complement	5-6
5-3.	RF Generator Troubleshooting.....	5-4	6-1.	Reference Designation Index	6-2
			6-2.	Replaceable Parts.....	6-9

SECTION O INTRODUCTION

O-1. Scope.

This manual describes Signal Generator AN/ USM-47 (Hewlett-Packard Model 626A), and provides instructions for operation and maintenance. The manual includes a components of end item list (COEIL) (app B) and a maintenance allocation chart (MAC) (app D). Repair parts and special tools lists (RPSTL) are included in TM 11-6625-2190-24P. Calibration procedures are contained in TB 9-6625-776-50. The manual applies directly to HF Model 626A signal generators having serial number prefix 1210A- below 01731. For serial numbers prefixed 1202A or lower, see appendix G; for serial numbers 1210A01731 and above, see appendix H.

O-2. INDEXES OF PUBLICATIONS.

a. *DA Pam 310-4.* Refer to the latest issue of DA Pam 310-4 to determine whether there are new editions, changes, or additional publications pertaining to the equipment.

b. *DA Pam 310-7.* Refer to DA Pam 310-7 to determine whether there are modification work orders (MWO's) pertaining to the equipment.

O-3. FORMS AND RECORDS.

a. *Reports of Maintenance and Unsatisfactory Equipment.* Maintenance forms, records and reports which are to be used by maintenance personnel at all maintenance levels are listed in and prescribed by TM 38-750.

b. *Report of Packaging and Handling Deficiencies.* Fill out and forward DD Form 6 (Packaging Improvement Report) as prescribed in AR 700-58/NAVSUPINST 4030.29/AFR 71-13/MCO P4030.29A and DLAR 4145.8.

c. *Discrepancy in Shipment Report (DISREP) (SF 361).* Fill out and forward Discrepancy in Shipment Report (DISREP) (SF 361) as prescribed in AR 55-

38/NAVSUPINST 4610.33BiAFR 75-18, ' MCO P4610.19B and DLAR 4500.15.

O-4. REPORTING EQUIPMENT IMPROVEMENT RECOMMENDATIONS (EIR).

EIR's will be prepared using SF 368 (Quality Deficiency Report). Instructions for preparing EIR's are provided in TM 38-750, The Army Maintenance Management System. EIR's should be mailed direct to Commander, US Army Communications and Electronics Materiel Readiness Command, ATTN: DRSEL-ME-MQ, Fort Monmouth, NJ 07703. A reply will be furnished direct to you.

O-5. ADMINISTRATIVE STORAGE.

Administrative storage of equipment issued to and used by Army activities shall be in accordance with TM 740-90-1.

O-6. DESTRUCTION OF ARMY ELECTRONICS MATERIEL.

Destruction of Army electronics materiel to prevent enemy use shall be in accordance with TM 750-244-2.

O-7. HAND RECEIPTS.

Hand receipts for Components of End Item (COEI), Basic Issue Items (BII), and Additional Authorization List (AAL) items are published in a hand receipt manual, TM 11-6625-2910-14-HR. This manual is published to aid in property accountability and is available through: Commander, US Army Adjutant General Publications Center, ATTN: AGDL-OD, 1655 Woodson Road, St. Louis, MO 63114.

Change 1 O-1

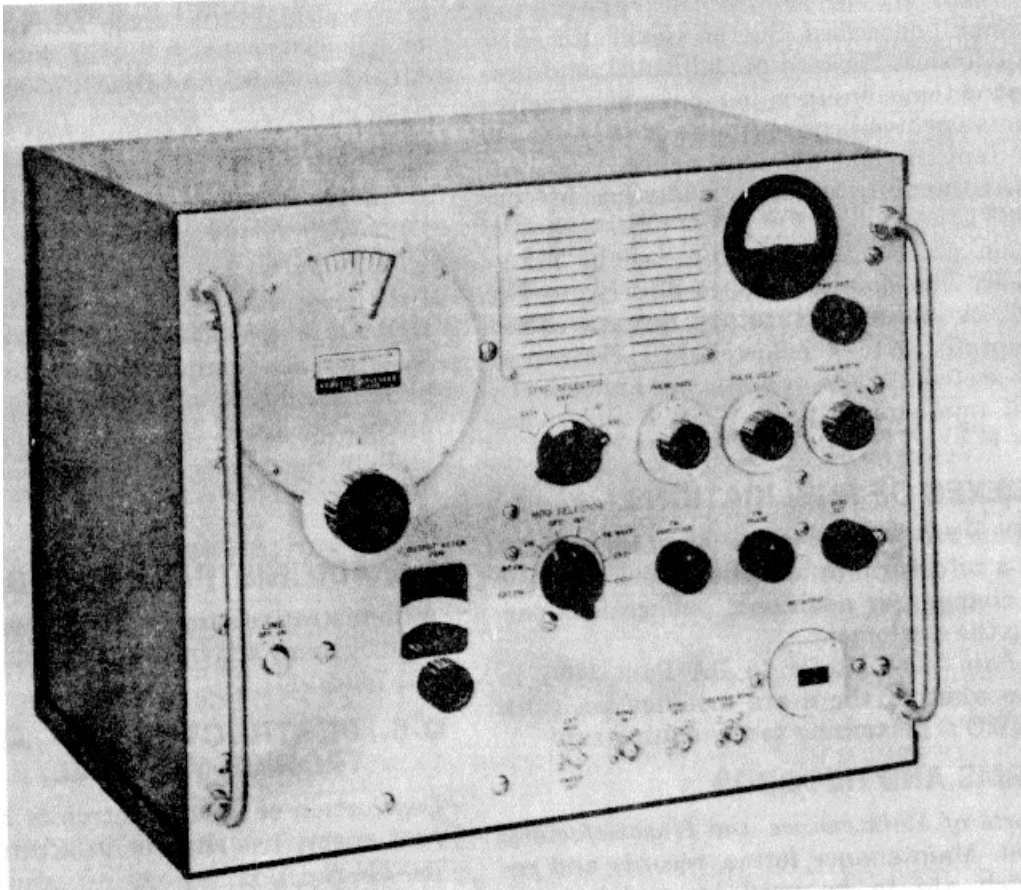

Figure 1-1. HP Model 626A SHF Signal Generator

Table 1-1. Specifications

Frequency Range: 10 to 15.5 GHz	Leakage: Less than minimum calibrated signal generator output
Frequency Calibration: Dial read directly in GHz; accuracy better than $\pm 1\%$	Modulation: Internal or external pulsed, FM or square wave
Output Range: 10 mW to 1 pW (+10dBm to -90dBm); attenuator dial directly calibrated in output dbm; swr less than 2.5 at +10 dBm; 1.35 at 0 dBm and lower	Internal Pulse Modulation: Repetition rate variable from 40 to 4000 pps; pulse width variable 0.5 to 10 microseconds
Output Monitor Accuracy: Better than +1 dB	Sync Out Signal: 20 to 50 volts amplitude into 1000-ohm load. Better than one microsecond rise time (1) Simultaneous with RF pulse - positive (2) In advance of RF pulse - positive, variable 5 to 300 microseconds
Output Attenuator Accuracy: Better than $\pm 2\%$ of attenuation in dB introduced by output attenuator	External Synchronization: (1) Sine wave, 40 to 4000 Hz, amplitude 5 to 50 volts rms (2) Pulse signals 0 to 4000 pps, 5 to 50 volts amplitude, positive or negative; pulse width 0.5 to 5 microseconds; rise time 0.1 to 1 microsecond
Output Connector: 0.850 in. by 0.475 in. waveguide, WR-75 Flat Cover Flange	

SECTION I GENERAL INFORMATION

1-1. DESCRIPTION.

1-2. The HP Model 626A SHF Signal Generator (Figure 1-1) is a general purpose broadband signal generator which produces RF output voltages from 10 to 15.5 GHz. The output frequency is set with a single control and is directly read on a dial calibrated to an accuracy of 1% or better. The output power level is continuously adjustable from -90 dBm (1 pW to above 10 milliwatts) over the full frequency range. The attenuator calibration is accurate within +2% of the attenuation in dB introduced by the attenuator.

1-3. The Model 626A is provided with versatile modulation characteristics. The output can be frequency modulated, square-wave modulated, or pulse modulated by internally or externally generated signals. The Model 626A also provides synchronizing pulses for external equipment being used.

1-4. In addition to producing an accurate and controllable radio-frequency test signal, the Model 626A is useful for the following:

- a. Testing pulse systems.

- b. Measuring sensitivity and selectivity of amplifiers, receivers, and other tuned systems.

- c. Measuring signal-to-noise ratio of RF signals.

- d. Making slotted line measurements.

- e. Investigation of microwave impedances and other transmission line characteristics.

- f. Measuring frequency response of microwave systems.

- g. Determining resonant frequency and Q of waveguide cavities.

1-5. The Model 626A has a self-contained modulator and power supply located on a deck at the rear of the instrument. The entire chassis and cabinet are fabricated from aluminum alloy. Guard rails are provided on the front panel to facilitate handling, and to protect the operating controls. Front panel connectors are of the BNC type except for the output connector which is rectangular waveguide. Etched circuit construction is used extensively, and circuit accessibility is very good.

Table 1-1. Specifications (Cont'd)

<p>Internal Square Wave Modulation: Variable 40 to 4000 Hz controlled by "pulse rate" control</p> <p>Internal Frequency Modulation: Power line frequency, deviation up to ± 5 MHz.</p> <p>External Pulse Modulation: Pulse Requirements: Amplitude 15 to 70 volts peak positive or negative; width 1.0 to 2500 microseconds</p> <p>External Frequency Modulation: Provides capacitive coupling to repeller of klystron; maximum deviation approximately ± 5 MHz.</p> <p>Power Source: 115 or 230 volts $\pm 10\%$, 50 to 60 Hz, approximately 200 watts</p> <p>Accessories Furnished: HP MX292B, M to X band waveguide adapter, WR-75 to WR-90 guide HP MP292B, M to P band waveguide adapter, WR-75 to WR-62 guide</p>	<p>Dimensions: Cabinet Mount: 17 in. wide, 14 in. high, 15 in. deep Rack Mount:</p> <div style="text-align: center;"> </div> <p>Weight: Net 65 lb</p> <p>Accessories Available: M362A Low Pass Filter</p>
--	--

1-6. ACCESSORIES FURNISHED.

1-7. The Model 626A is supplied with two different waveguide adapters for connecting the rf output waveguide to either X- or P-band waveguide. The adapters are as follows: Model MX292B used to connect to X-band waveguide; and Model MP292B used to connect to P-band waveguide.

1-8. ACCESSORIES AVAILABLE.

1-9. To suppress second and third harmonics an additional 40dB, an HP Model M362A Low Pass Filter is recommended.

1-10. INSTRUMENT IDENTIFICATION.

1-11. Refer to paragraph O-1 for coverage on instrument identification and differences. Refer to the ERRATA section of appendix H for changes coverage applicable to all instruments.

SECTION II INSTALLATION

2-1. INSPECTION.

2-2. Unpack the instrument upon receipt and inspect it for signs of physical damage such as scratched panel surfaces, broken knobs, etc. If there is any apparent damage, file a claim with the carrier and refer to the warranty page in this manual.

2-3. An electrical inspection should be performed as soon as possible after receipt. See Section V, paragraph 5-62 for performance checks. These procedures make a good test as part of incoming quality control inspection.

2-4. AIR FILTER.

2-5. This instrument is equipped with a renewable type air filter. When first placing the instrument into service, the filter must be coated with a dirt-gathering adhesive. We recommend a water-soluble adhesive such as Super Filter Coat from Research Products Corporation. This adhesive comes in a convenient spray can and is available from most heating supply stores or from your authorized Hewlett Packard sales representative (HP Part No. 3150-0002). For preventive maintenance on the air filter, refer to paragraph 5-3.

2-6. POWER REQUIREMENTS.

2-7. The Model 626A requires a power source of 115 or 230 volts +10%, 50to60 Hz, which can deliver approximately 200 watts.

2-8. POWER CABLE.

2-9. This instrument is equipped with a three-prong conductor power cable which, when plugged into an appropriate receptacle, grounds the instrument. The offset pin on the power cable three-prong connector is the ground pin.

2-10. To preserve the protection feature when operating the instrument from a two contact outlet, use a three-prong to two-prong adapter and connect the pigtail on the adapter to ground (HP Part No. 12510048).

2-11. 230-VOLT OPERATION.

2-12. To operate the Model 626A from a 230-volt +10% source, proceed as follows:

- a. Turn unit off.
- b. Place 115/230 switch on rear to 230 volt position.
- c. Change the line fuse to 2 ampere.

2-13. REPACKAGING FOR SHIPMENT.

2-14. The following list is a general guide for repackaging an instrument for shipment. If you have any questions, contact your authorized Hewlett Packard sales representative.

- a. If possible, use the original container designed for the instrument.
- b. Wrap the instrument in heavy paper or plastic before placing it in the shipping container.
- c. Use plenty of packing material around all sides of the instrument and protect the panel with cardboard strips.
- d. Use a heavy cardboard carton or wooden box to house the instrument and use heavy tape or metal bands to seal the container.
- e. Mark the packing box with "Fragile", "Delicate Instrument", etc.

Note

If the instrument is to be shipped to Hewlett Packard Company for service or repair, attach to the instrument a tag identifying the owner and indicating the service or repair to be accomplished. In any correspondence be sure to identify the instrument by model number, serial prefix, and serial number.

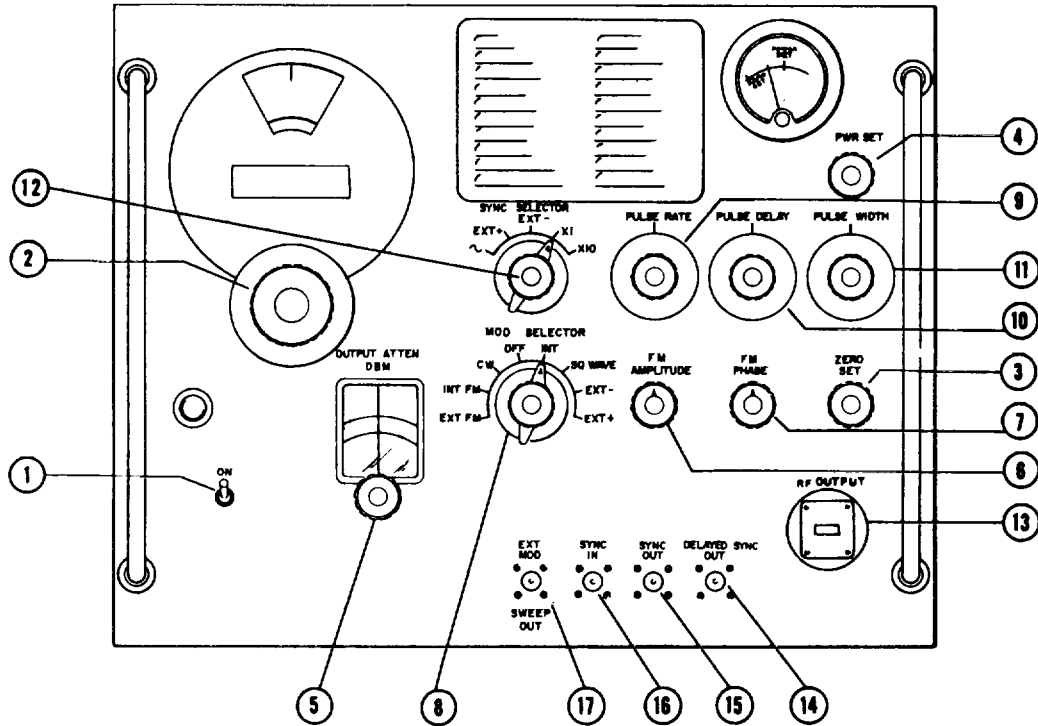

1. Turns on line power to the instrument.
2. Frequency control (not labeled) is used to set to desired RF output frequency. Frequency dial is read directly in KILOMEGACYCLES (GHz).
3. ZERO SET control is used to zero- set the power-monitor meter.
4. PWR SET control is used to establish the correct power level fed to the output attenuators.
5. OUTPUT ATTEN control adjusts the RF output level from + 10 dBm to - 90 dBm (10 mW to 1 pW).
6. FM AMPLITUDE control adjusts the frequency deviation of the output signal when internal or external frequency modulation is employed.
7. FM PHASE control adjusts the phase of frequency modulation from approximately +90 degrees to - 90 degrees with respect to the SWEEP OUT signal only when internal frequency modulation is employed.
8. MOD SELECTOR switch is used to select the desired type of modulation to be applied to the RF output signal.
9. PULSE RATE control adjusts the repetition rate of the RF output pulse or square wave when the MOD SELECTOR is set to INT or SQ WAVE. The X1 or X10 positions of the SYNC SELECTOR determines the multiplying factor to be applied to the reading of the calibrated PULSE RATE dial.
10. PULSE DELAY control adjusts the time delay between the leading edge of the SYNC OUT pulse and the RF output pulse from 3 to 300 microseconds when the MOD SELECTOR is set to INT.
11. PULSE WIDTH control adjusts the width of the RF output pulse from 0.5 to 10 microseconds when the MOD SELECTOR is set to INT.
12. SYNC SELECTOR switch is used to select the type of synchronization to be employed by the signal generator during internal pulse modulation of the RF output signal.
13. RF OUTPUT: M band type WR-75 waveguide, cover type flange.
14. DELAYED SYNC OUT connector is the output for delayed sync pulses in either square-wave or pulse operation. These pulses are controlled by PULSE DELAY.
15. SYNC OUT connector is the output for sync pulses in either square- wave or pulse operation.
16. SYNC IN connector is the input for sync pulses. These pulses are used only when MOD SELECTOR is set to INT and SYNC SELECTOR to EXT-, EXT + or ~.
17. EXT MOD/SWEEP OUT: This connector is used as an input for external modulation signals when MOD SELECTOR is set to EXT FM, EXT- or EXT +. The connector is also used as an output for a sweep signal which occurs only when MOD SELECTOR is set to INT FM.

Figure 3-1. Operating Controls and Connectors

SECTION III OPERATING INSTRUCTIONS

3-1. INTRODUCTION.

3-2. This section contains instructions for the various modes of operation; each is covered in the operating procedure, paragraph 3-6. Front panel controls and connectors and their uses are shown in Figure 3-1.

3-3. HARMONICS.

3-4. At output levels between 50 and +10 dBm, harmonics in the RF output are at least 20 dB below the fundamental frequency. Normally harmonics will not degrade measurements such as determining sensitivity of tuned receivers or tuned systems. However, when measuring standing wave ratios, accuracy can be increased by using a low-pass filter which suppresses second and third harmonics. A low-pass filter with a broad stop band, such as the HP Model M362A is recommended.

3-5. The signal generator attenuator will affect only the fundamental frequency, and therefore harmonics can be identified.

3-6. OPERATING PROCEDURE.

3-7. The operation of the Model 626A consists of adjusting the two major sections: the RF section, and the modulator section. Adjust the RF section first, since this adjustment establishes the output power reference level, for the output attenuators.

3-8. After turning the instrument on, allow it at least 5 minutes to reach a stable operating temperature. If the ambient temperature is below 100C(50uF) a longer warmup period is necessary.

Note

The klystron tube used in this instrument is expensive and has a shorter life than that of the conventional vacuum tube. When the MOD SELECTOR switch is set to OFF, filament and plate voltages are still present on the klystron tube, and therefore power should be removed from the instrument when it is not in use in order to increase the useful life of the tube. Average tube life approximates 1000 hours and the warranty period approximates 500 hours.

3-9. CW OUTPUT.

- a. Set frequency dial for desired frequency output.
- b. Set MOD SELECTOR to OFF, and adjust ZERO SET to obtain a power-monitor meter indication exactly on the ZERO SET index.
- c. Set MOD SELECTOR to CW, and adjust PWR

SET to obtain a meter indication exactly on the POWER SET index (red line at center of scale).

- d. Set OUTPUT ATTEN for the desired RF output level in dBm as indicated on the calibrated attenuator scale.

3-10. SQUARE-WAVE OUTPUT.

- a. After obtaining the desired CW level as described in paragraph 3-9, set MOD SELECTOR to SQ WAVE.
- b. Set SYNC SELECTOR to the X1 or X10 position, and adjust PULSE RATE to obtain the desired squarewave frequency.
- c. A synchronizing pulse coincident with the rise of each cycle of square wave is available at the SYNC OUT connector on the front panel.

3-11. INTERNAL PULSE MODULATION.

- a. After obtaining the desired CW level as described in paragraph 3-9, set MOD SELECTOR to INT.
- b. Set SYNC SELECTOR to X1 or X10, and adjust PULSE RATE to obtain the desired pulse repetition rate.

- c. Adjust PULSE WIDTH to obtain the desired width of RF output pulse.

- d. Adjust PULSE DELAY to obtain the desired delay between the leading edge of the RF output pulse and synchronizing pulse obtained at SYNC OUT.

- e. To synchronize any external equipment, use the SYNC OUT and/or DELAYED SYNC OUT pulses.

3-12. EXTERNAL PULSE MODULATION.

- a. After obtaining the desired CW level as described in paragraph 3-9, set MOD SELECTOR to EXT + or EXT to match the polarity of the external modulating pulse.
- b. Connect the modulating pulse to EXT MOD connector. The modulating pulse must have an amplitude of at least 15 volts peak.

3-13. INTERNAL FM AT LINE FREQUENCY.

- a. After obtaining the desired CW level as described in paragraph 3-9, set MOD SELECTOR to INT FM and SYNC SELECTOR to ~ .
- b. Set FM AMPLITUDE control to the full counterclockwise position, then advance it slowly to establish the desired degree of RF frequency deviation about the center frequency. If the control is advanced too far, the modulating voltage may drive the klystron out of the desired mode of oscillation.

Section III

3-14. To observe a presentation of the mode pattern, connect the RF output through a detector to the vertical plates of an oscilloscope and the SWEEP OUT signal to the horizontal plates of the oscilloscope. This method of viewing the mode pattern is recommended when adjusting the reflector-tracking potentiometers.

3-15. EXTERNAL FM.

a. After obtaining the desired CW level as described in paragraph 3-9, set MOD SELECTOR to EXT FM.

b. Connect the external frequency modulation signal to the EXT MOD connector. The modulating signal must have an amplitude of 20 to 30 volts rms.

c. Set FM AMPLITUDE control to the full counterclockwise position, then advance it slowly to establish the desired degree of FM about the center frequency. If the control is advanced too far, the modulating voltage may drive the klystron out of the desired mode of oscillation. The FM PHASE control cannot be used to control the phase of modulating signals supplied from an external source.

3-16. To observe a presentation of the mode pattern, connect the RF output through a detector to the vertical plates of an oscilloscope and connect the external frequency modulation signal to the horizontal plates of the oscilloscope.

**SECTION IV
PRINCIPLES OF OPERATION**

4-1. INTRODUCTION.

4-2. The Model 626A contains five main circuit sections and a regulated power supply. The five main circuit sections, and all front panel controls and connectors are shown in block diagram, Figure 4-2. These circuits provide FM, CW, squarewave, and pulse modulated signals in the 10- to 15.5-GHz range.

4-3. PULSE SECTION.

4-4. This section generates all pulses for internal modulation and synchronizing external equipment. The circuits of the pulse section are shown in Figure 4-3, and explained in the following paragraphs. The time relationship between pulses is shown in Figure 4-1

4-5. INPUT AMPLIFIER AND PULSE RATE MULTIVIBRATOR.

4-6. The functions of input amplifier and pulse rate multivibrator V9 are dependent upon the position of the SYNC SELECTOR switch. Refer to Figure 4-4.

a. With SYNC SELECTOR switch S2 at position 1(-) or 2 (EXT +), V9 is an input amplifier for

sine waves and positive pulses, and with S2 at position 3 (EXT-), V9 is an input inverter amplifier for negative pulses.

(1) In position 1 or 2, the input signal is applied to the grid of V9A and the grid of V9B is grounded through capacitor C22. The output signal, in phase with the input signal, is taken from the plate of V9B and couples to V10 which is arranged as a Schmitt Trigger.

(2) In position 3, the input signal is applied to the grid of V9B and the grid of V9A is grounded through capacitor C22. The output signal, 180 out of phase with the input signal, is taken from the plate of V9B and coupled to V10.

b. With S2 in positions 4 (X1) and 5 (X10), V9 becomes a free running multivibrator. The frequency of oscillation is determined by time constants of the RC networks and a variable positive voltage towards which the grids are returned.

(1) In position 4 (X1) frequency of oscillation is from 40 to 400 pps and the RC network consists of C16-R35 and C20-R42.

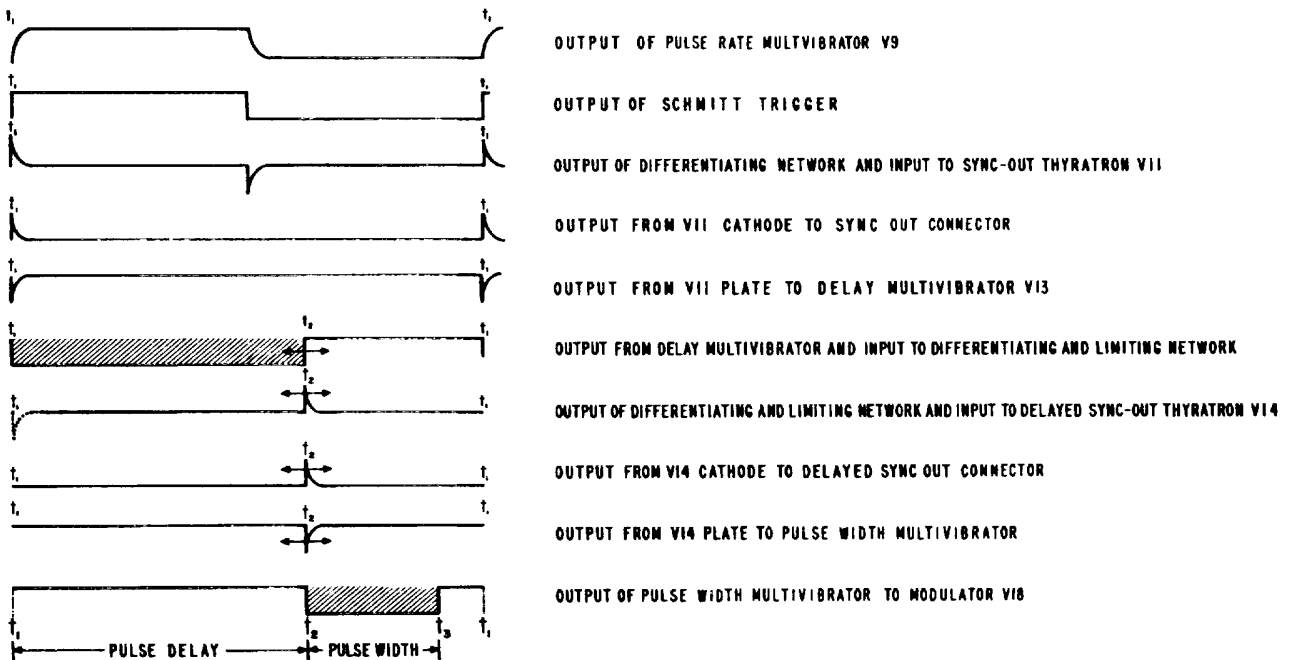

Figure 4-1. Timing Sequence in Pulse Section

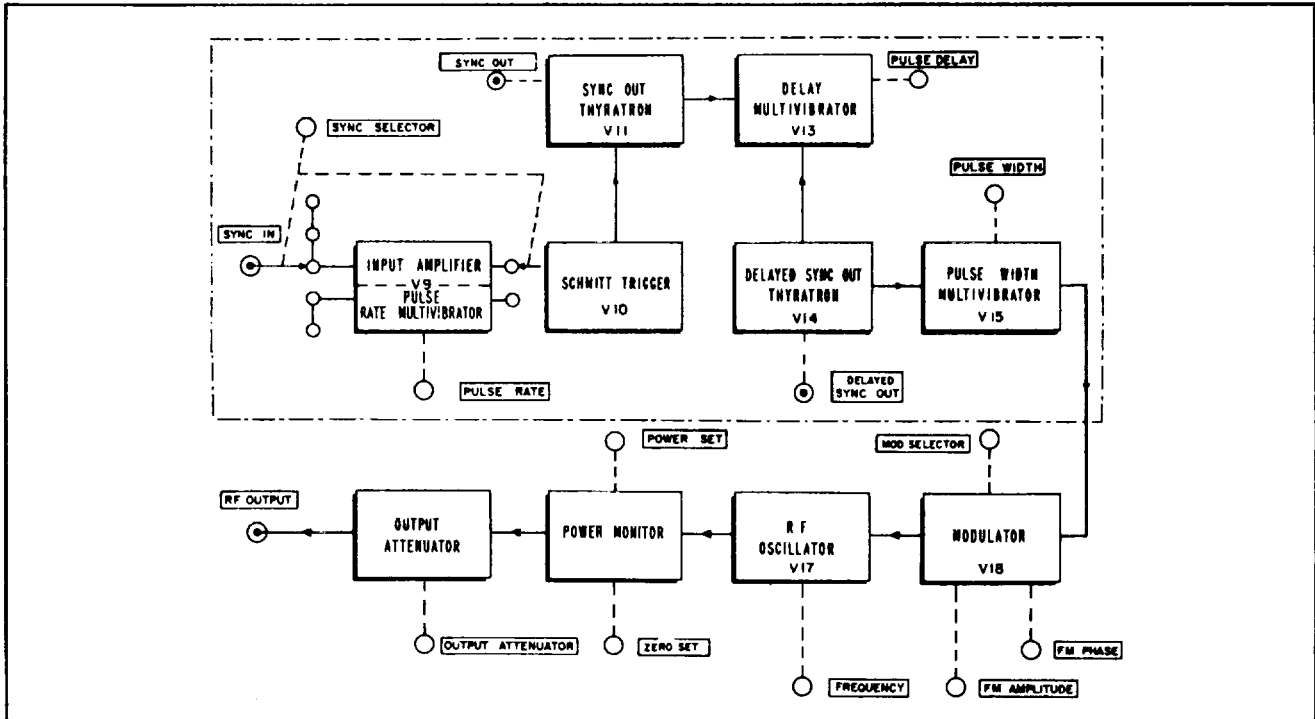

Figure 4-2. Block Diagram

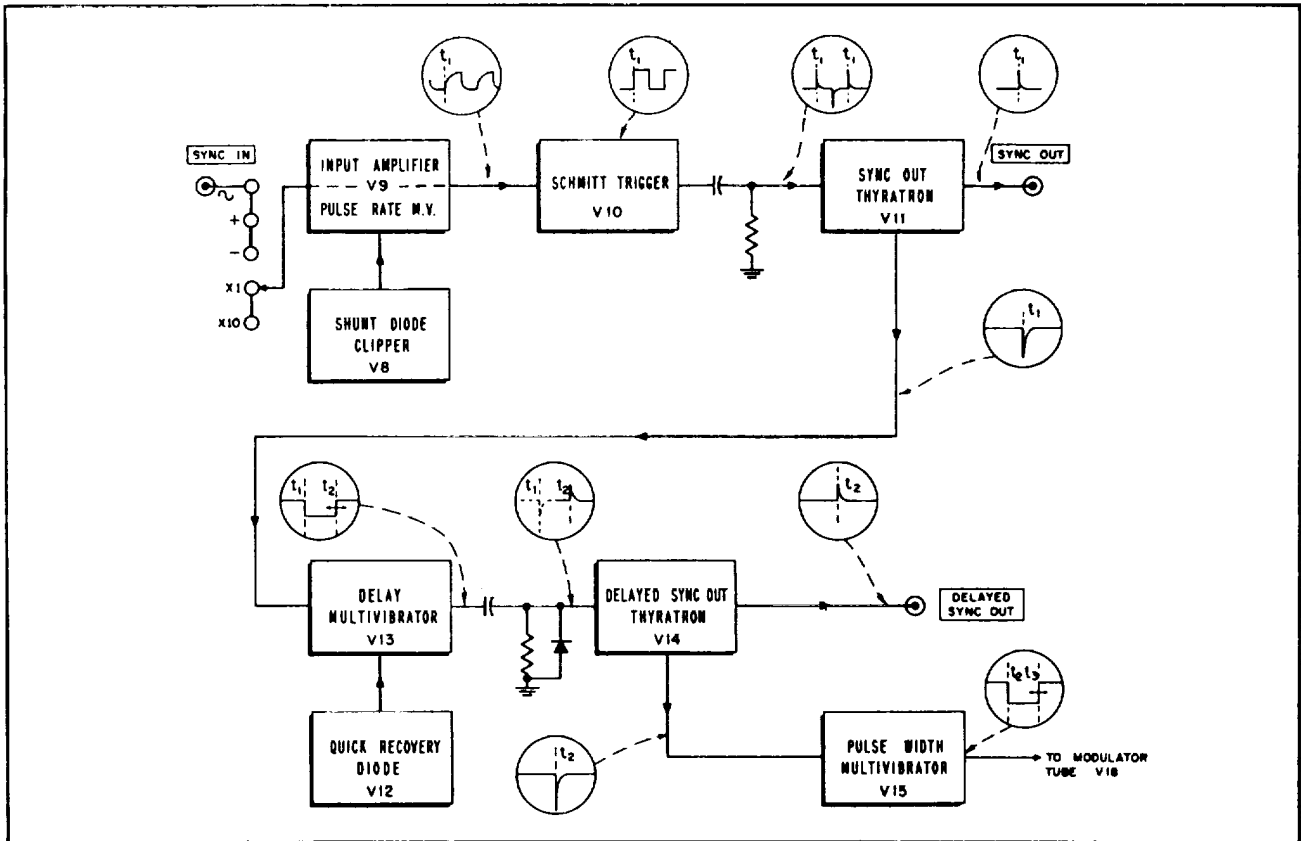

Figure 4-3. Block Diagram of Pulse Section Showing Waveforms

Model 626A

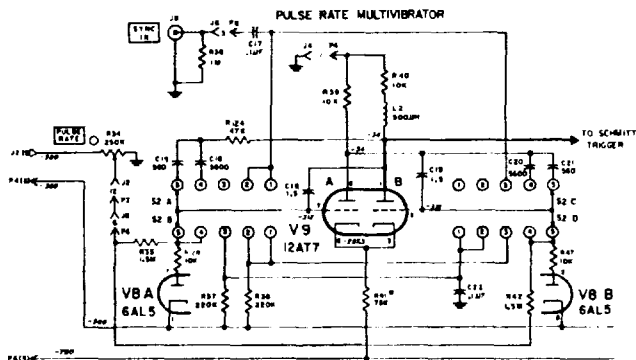

Figure 4-4. Input Amplifier and Pulse Rate Multivibrator

(2) In position 5 (X10) frequency of oscillation is from 400 to 4000 pps and the RC network consists of C15-R35 and C21-R42. Note that C15 and C21 are one tenth the capacity of C16 and C20, and thus the RC time in the X10 position is one tenth of that in the X1 position, giving a frequency multiplication of ten.

4-7. PULSE RATE control, R34, varies the voltage towards which the timing capacitors tend to discharge, hence the time it takes the instantaneous grid voltage to reach cut off value in the discharge period of the RC networks.

4-8. The two sections of V8 act as clamping diodes which prevent V9 grids from drawing grid current on their positive swing. Both diodes are clamped to -300 volts and they conduct whenever the instantaneous grid voltages go positive with respect to -300V. This action prevents any transients from appearing in the plate circuits, thereby improving the output waveform.

4-9. The output signal taken from the plate of V9B is coupled, by capacitor C23, to the grid of V10A.

4-10. SCHMITT TRIGGER.

4-11. A pulse of fast rise and decay time is required for triggering thyatron V11. Therefore the output from V9 is passed through a schmitt trigger circuit before being applied to sync out thyatron V11. The schmitt trigger circuit is shown in Figure 4-5.

4-12. Transition from one state to the other in a schmitt trigger circuit (a direct coupled multivibrator) is very fast, which results in a square wave output of sharp waveform. V10 reverses conduction when the rise of the input signal reaches an upper trigger level, and again when the decay of the input signal goes through a lower trigger level. These trigger levels are established by the change in potential in the common cathode circuit which results from the difference in conduction through two sections of V10. The upper trigger level is established when V10B is conducting and is approximately -223 volts. The hysteresis of the circuit is 10-11 volts which places the decaying trigger level at approximately 233 volts when V10A is conducting.

4-13. The voltage divider composed of R43, R44, R45, and R46 establishes the no-signal level on the V10A grid below the lower trigger level or at approximately -234 volts.

4-14. Maximum sensitivity of the schmitt trigger is obtained when the average DC level of the input signal is so set that the signal is symmetrical with respect to the two trigger levels. The average DC level at the input to V10 is raised or lowered by adjustment of Trigger Level Adj. (R44), which in turn adjusts the duty cycle of the square-wave output.

4-15. The signal which will be used for square-wave modulation is provided by the schmitt trigger. To avoid loading the output of V10B, the squarewave modulating voltage is taken from the plate of V10A, and is coupled to modulator V18 when MOD SELECTOR switch S3 is in SQ WAVE.

4-16. The output signal is taken from the plate of V10B for triggering thyatron V11.

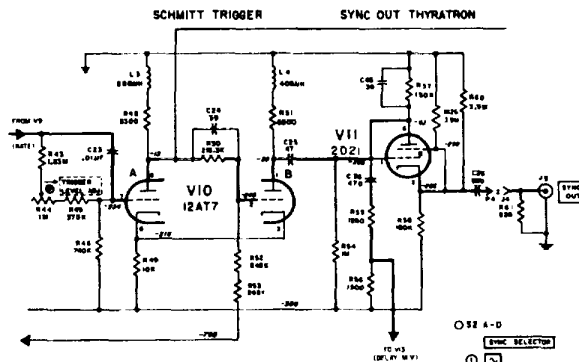

Figure 4-5. Schmitt Trigger and Sync Out Thyatron

4-17. SYNC OUT THYRATRON.

4-18. The output of V10B is differentiated by C25 and R54. The sharp positive spike fires sync out thyatron V11 (Figure 4-5) by driving its grid positive. A large negative pulse (-130 volts peak) is developed in the plate circuit of V11 and is fed through C38 and R55 to delay multivibrator V13. A positive pulse (30 volts peak) appears at the cathode of V11 and is fed to the SYNC OUT connector through C26. This sync signal is simultaneous in time with the front of the original pulse established by the pulse rate multivibrator or by an external source of sync signals. The time relationships are indicated in Figure 4-1.

4-19. DELAY MULTIVIBRATOR.

4-20. Delay multivibrator V13 (Figure 4-6) produces an output pulse whose width is variable from 3 to 300 us with respect to its leading edge t_1 , see Figure 4-1. Its trailing edge establishes time reference t_2 . The width of the output pulse is controlled by setting PULSE DELAY control, R80.

Section IV

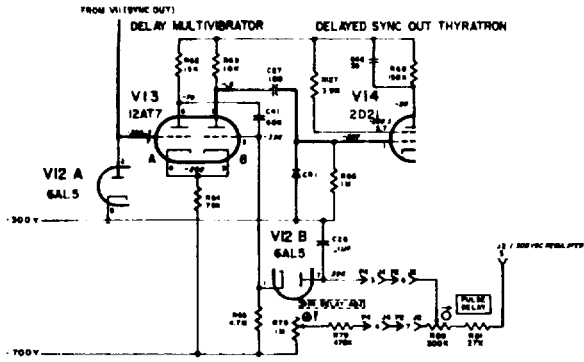

Figure 4-6. Delay Multivibrator

4-21. Delay multivibrator V13, is arranged as a one shot multivibrator, with a diode clamp in each of its grid circuits. Diode V12A clamps V13A grid to prevent it from going more positive than 300 volts. Diode V12B clamps V13B grid to prevent it from going more negative than a level determined by the setting of the PULSE DELAY control, a level which is somewhere below cutoff. Under no signal conditions V13A is conducting, V13B is cut off, and V12B is conducting. When the circuit is in the no-signal condition, the potential on V13B grid is established through V12B and is essentially the same as the potential on V12B plate.

4-22. When the large negative pulse from V11 is applied to the grid of V13A, conduction in V13A ceases, and the positive signal developed in the plate of V13A is coupled to the grid of V13B through timing capacitor C41. V13B conducts, V12B cuts off, and C41 discharges through R65 towards 650 volts, pulling the grid of V13B more negative until cutoff is reached. V13A then starts to conduct, and the negative signal developed in the plate of V13A is coupled to the grid of V13B, driving the V13B grid negative from cutoff by an amount equal to the plate swing of V13A. Diode V12B starts to conduct, C41 discharges through V12B, and the V13B grid is returned to the no-signal condition in a very short time. Waveforms shown in Figure 4-7 illustrate the decrease in recovery time obtained by use of grid clamp V12B.

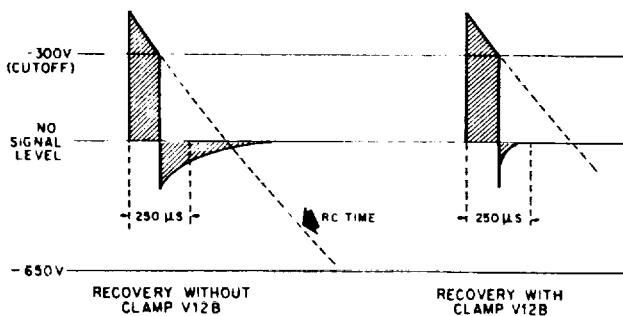

Figure 4-7. Waveform Comparison

4-23. Rapid return of V13B grid to the no signal level is required so that the delay multivibrator will be prepared to receive the next pulse incoming from VII. Since at high pulse repetition rates the period between pulses is short (250 μs at 4000 pps), interaction would occur if grid recovery time is short.

4-24. The relation between changes in grid level and pulse width is indicated in the waveform diagram Figure 4-8. The width of the output pulse is dependent upon two things: the RC time constant of C41-R65 and the level of potential on the V13B grid when the delay multivibrator is in the no-signal condition. While the RC time can not be varied, the level of potential on the V13B grid can be raised or lowered by changing PULSE DELAY control. For example, when PULSE DELAY is set so that the no-signal level on V13B grid is approximately -390 volts, the positive pulse from V13A will drive V13B grid very little above cutoff, conduction time of V13B will be brief, and therefore the width of the output pulse will be greatly shortened.

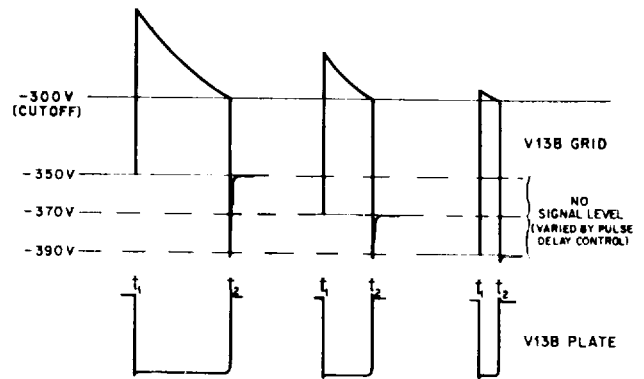

Figure 4-8. Delay Multivibrator Grid and Plate Waveforms

4-25. With PULSE DELAY at minimum, variable resistor R78 adjusts the minimum interval between the leading (t_1) and trailing (t_2) edges of the output pulse, thus effecting minimum delay of the RF output pulse with respect to t_1 .

4-26. The output of V13B is differentiated by C27 and R66, and the negative spike, corresponding to t_1 is eliminated through diode CR1. The positive spike, representing time reference t_2 , is passed to delayed sync out thyatron V14.

4-27. DELAYED SYNC OUT THYRATRON.

4-28. The action of delayed sync out thyatron V14 (Figure 4-9) is similar to that described for sync out thyatron V11 (paragraph 4-17). The positive differentiated spike from V13 fires the thyatron. The positive pulse (30-volt peak) developed in the V14 cathode circuit is fed to the DELAYED SYNC OUT connector, and the large negative pulse developed in the V14 plate circuit is coupled to width multivibrator V15.

4-29. PULSE WIDTH MULTIVIBRATOR.

4-30. The action of pulse width multivibrator V15 (Figure 4-9) is similar to that of delay multivibrator

Model 626A

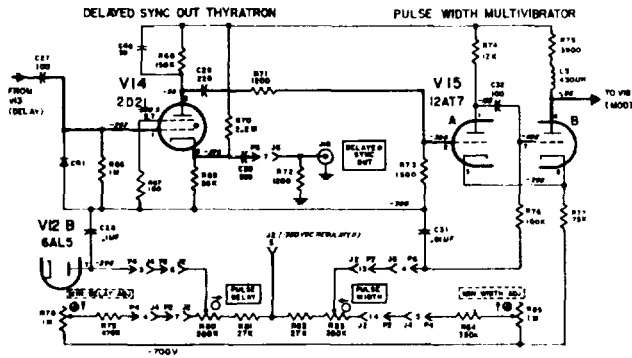

Figure 4-9. Delayed Sync Out Thyatron and Width Multivibrator

V13 (paragraph 4-19) except that there is no diode in the V15B grid circuit to shorten recovery time. Normal recovery time is adequate to return the circuit to the no signal condition before the next pulse is received from V14.

4-31. Bias for the V15B grid is applied through a voltage divider, R82R85, which includes variable resistor R83, brought out to the front panel as the PULSE WIDTH control. The relation between level of grid potential and width of output pulse was discussed in

paragraph 4-24. The pulse width multivibrator provides an output pulse whose width is variable from 0.5 to 10 μ s. The trailing edge of the V15B output pulse establishes time reference t_3 , see figure 4-1. With pulse width at minimum, variable resistor R85 adjusts the minimum interval between the leading (t_2) and trailing (t_3) edges of the output pulse, thus effecting minimum width of the RF output pulse with respect to t_2 .

4-32. The V15B output pulse is coupled to the grid of V18B in the modulator section when the MOD SELECTOR switch is set to INT.

4-33. MODULATOR SECTION.

4-34. The modulator section (Figure 4-10) includes modulator tube V18 and MOD SELECTOR switch S3. This section receives all pulse and squarewave modulation signals to be applied to the RF oscillator section. The modulator tube functions only in positions 4, 5, 6, and 7 of S3. In positions 1 and 2 FM signals are applied to the klystron reflector. In position 3 no modulation signal is applied to the klystron, thus the RF output signal is a continuous wave. Circuit conditions at each position of S3 are as follows:

- a. Position 1 (EXT FM) -An externally-supplied FM signal, applied at the EXT MOD/SWEEP OUT connector, is placed across variable resistor R115 (FM

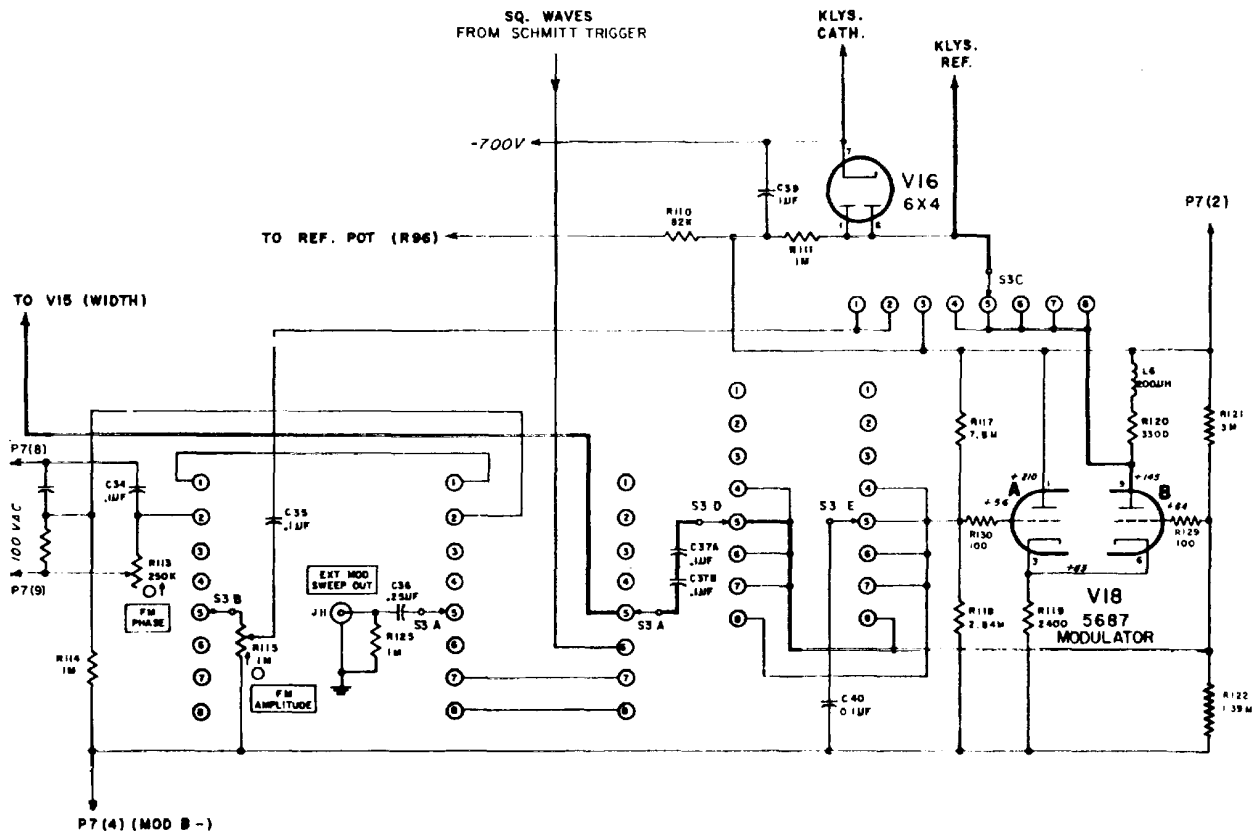

Figure 4-10. Modulator V18 and MOD SELECTOR Switch S3

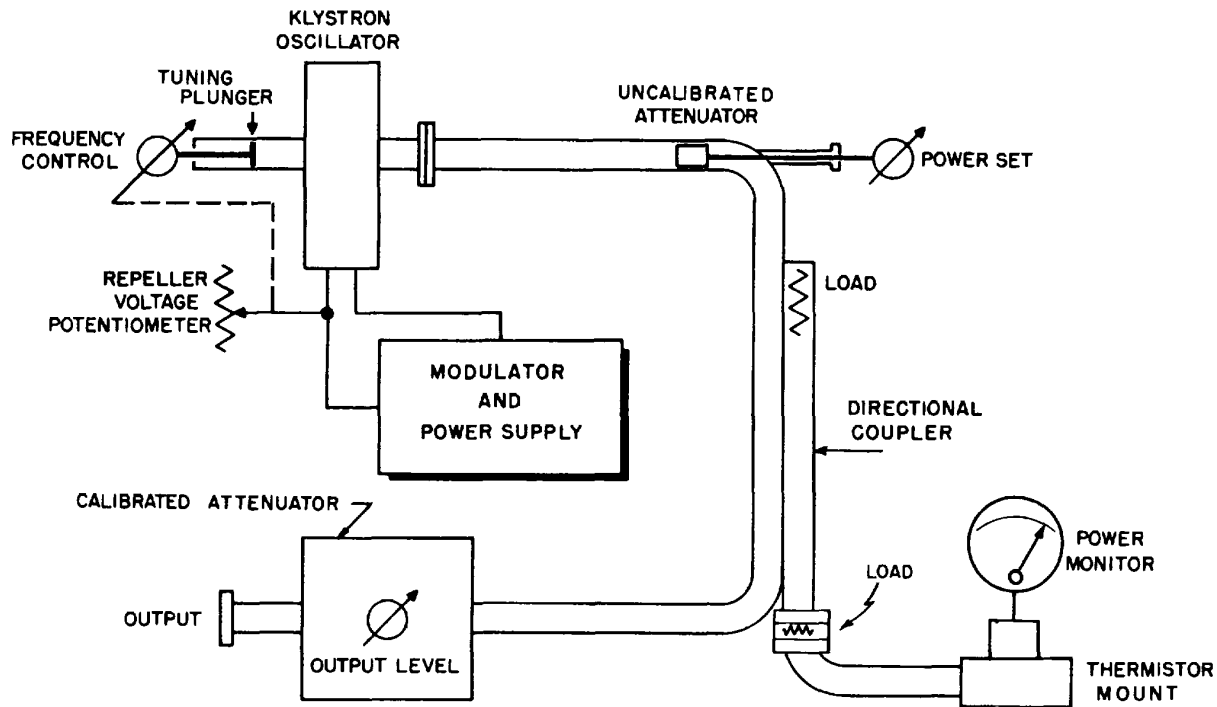

Figure 4-11. RF Oscillator and Waveguide System

AMPLITUDE control), and then coupled by capacitor C35 to the klystron reflector.

b. Position 2 (INT FM) -An internally-supplied FM signal of the same frequency as the line voltage is placed across R115 (FM AMPLITUDE control), and then coupled to the klystron reflector. This signal, taken from secondary winding B of power supply transformer T2 by leads P7 (8) and P7 (7), is applied to the modulator section through a phase-determining network which includes the FM PHASE control. The FM signal voltage is also supplied to the EXT MOD/SWEEP OUT connector.

c. Position 3 (CW)-In this position modulation is not applied to the klystron reflector and the RF output signal generated by the RF oscillator is a continuous wave.

d. Position 4 (OFF) - In this position the klystron reflector is tied to the plate of V18B. With the modulator section in the no-signal condition, V18A is cut off and V18B is conducting. The drop across the V18B plate load resistor (approximately 60 volts) drives the reflector outside the operating mode, and there is no oscillation.

e. Position 5 (INT) -In this position, modulating voltage is supplied from width multivibrator V15. In the no signal condition the circuit is as described for position 4. When a negative pulse from V15 is placed on its grid, V18B cuts off. Potential on the V18B plate rises, returning the klystron reflector to the operating level, and the klystron

oscillates. Oscillation continues for the duration of the pulse, and then the V18 circuit returns to the no-signal condition, again driving the klystron reflector outside the operating mode.

f. Position 6 (SQ WAVE) -The square-wave signal, from the VIOA section of the schmitt trigger is placed on the V18B grid. As described for position 5, the resulting action alternately changes the klystron reflector voltage so that the klystron moves in and out of oscillation.

g. Position 7 (EXT-) -The action in this position is identical to that described for position 5 except that the negative pulses that are applied to the modulator section are supplied from an external source at the EXT MOD/SWEEP OUT connector.

h. Position 8 (EXT+) -The action in this position is similar to that described for position 7 except that externally supplied pulses are applied to V18A grid. V18A conducts, V18B cuts off and allows the klystron to oscillate. In the EXT+ position V18 acts as a pulse inverter.

4-35. The action of diode V16 protects the klystron from drawing reflector current. V16 is connected across the cathode and the reflector, and conducts in the event the klystron reflector goes positive with respect to the klystron cathode.

4-36. RF OSCILLATOR SECTION.

4-37. The RF oscillator section (Figure 4-11) of the Model 626A is essentially an all waveguide system,

employing a reflex klystron tube mounted in a plunger tuned cavity for generation of the RF energy. The energy from the cavity is coupled to a power set attenuator (uncalibrated) which adjusts the power level applied to the calibrated attenuator. The level at the input of the calibrated attenuator is monitored by a compensated thermistor bridge which operates a front panel meter. Monitoring is accomplished by sampling the RF energy through a waveguide directional coupler which feeds the sampled RF energy to a thermistor located in one leg of the bridge. The calibrated attenuator is a rotary type, operating in circular waveguide with a transition to rectangular waveguide at its output.

4-38. REFLEX KLYSTRON OPERATION.

4-39. The resonant circuit of the RF oscillator includes klystron resonator-grid capacitance, beam admittance, and the primarily inductive impedance of the external cavity. The cavity is fitted with a movable plunger which changes cavity dimensions, thereby varying the impedance of the oscillator resonant circuit. With a change in impedance, the frequency of oscillation is changed.

4-40. Fig 4-13a and Fig 4-13b show equivalent circuits of a reflex klystron oscillator. In the following discussion of how oscillations are sustained in a reflex klystron oscillator, the presence of a low amplitude RF voltage across the resonator grids is assumed. As in any oscillator, this initial voltage is supplied by the thermal agitation noise.

4-41. Electrons emitted from the cathode toward the resonator grids are velocity modulated, i.e., the electrons are accelerated or decelerated according to the phase of the RF voltage existing across the resonator grids. After leaving the resonator grids, the electrons encounter a retarding electric field set up by the negative reflector voltage and are repelled back toward the grids. Since the electrons have been velocity modulated they tend to form in bunches when they arrive at the grids.

4-42. This bunching of electrons is illustrated in Figure 4-12, which shows the transit time relationship of electrons while in the drift space between the resonator grids and the reflector. Consider an electron (a) leaving the grids at time t_1 . The voltage of the RF signal on the grids is such that the electron receives energy and is accelerated into the drift space. It arrives back at the grids at time t_n . An electron (b) leaving at time t_2 receives no acceleration because the RF signal is now at zero volts. Thus electron (b) does not travel as far into the drift space and arrives back at the grids at the same time as electron (a). Electron (c) leaving at time t_3 is decelerated since the RF signal has reversed voltage polarity since time t_1 . Electron (c) travels a shorter distance into the drift space and arrives back at the grids at the same time as electrons (a) and (b).

4-43. When bunched electrons arrive back at the grids at a time when the RF signal tends to retard their return, they deliver energy to the grids and sustain oscillations in the resonant cavity.

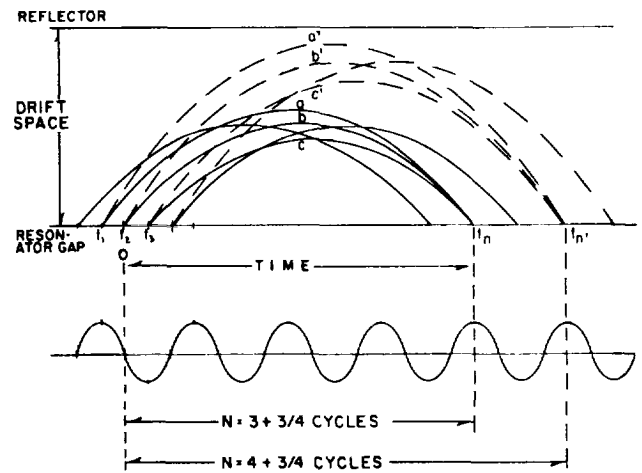

Figure 4-12. Bunching of Electrons in a Reflex Klystron

4-44. The time that the electrons spend in the drift space is adjusted by changing the reflector voltage. As reflector voltage is increased in the negative direction, electrons a, b, and c spend less time in the drift space. As reflector voltage is decreased electrons a^1 , b^1 , and c^1 (Figure 4-12) travel farther into the drift space and take a longer time (t_{n1}) to return to the grids. At the low end of the frequency band (10. 0 to 12. 8 GHz.), the reflector voltage is adjusted so that the number of oscillations (N) that occur at the grid while the electrons are in the drift space is equal to $3\text{-}3/4$ cycles. At the high end of the frequency band (12. 8 to 15. 5 GHz.), the reflector voltage is adjusted so that the number of oscillations equals $4\text{-}3/4$ cycles. When the oscillator is operating with $3\text{-}3/4$ cycles drift time it is known as operating in the $3\text{-}3/4$ reflector mode. A plot of reflector modes with respect to frequency and reflector voltage is given in Figure 4-14.

4-45. RF OSCILLATOR TUBE.

4-46. The RF oscillator tube is a Varian type V39B reflex klystron operating in a tunable cavity resonator. The klystron and cavity assembly are shown in Fig 5-4a and Fig 5-4b. The klystron is constructed with two irises located opposite each other and near the resonator grids. One iris looks into the external cavity and the other into the output system.

4-47. The klystron cavity system in the Model 626A operates on the $3/4$ wavelength cavity mode, and oscillation of both the $3\text{-}3/4$ and $4\text{-}3/4$ reflector modes are employed to cover the frequency band from 10.0 to 15.5 GHz. The $3\text{-}3/4$ mode is used from 10.0 GHz to approximately 12. 8 GHz. At this frequency the tuning mechanism actuates mode switch S4 to decrease the voltage applied to the reflector by approximately 250 volts. This action places the system on the $4\text{-}3/4$ mode for the remainder of the band from approximately 12.8 to 15.5 GHz.

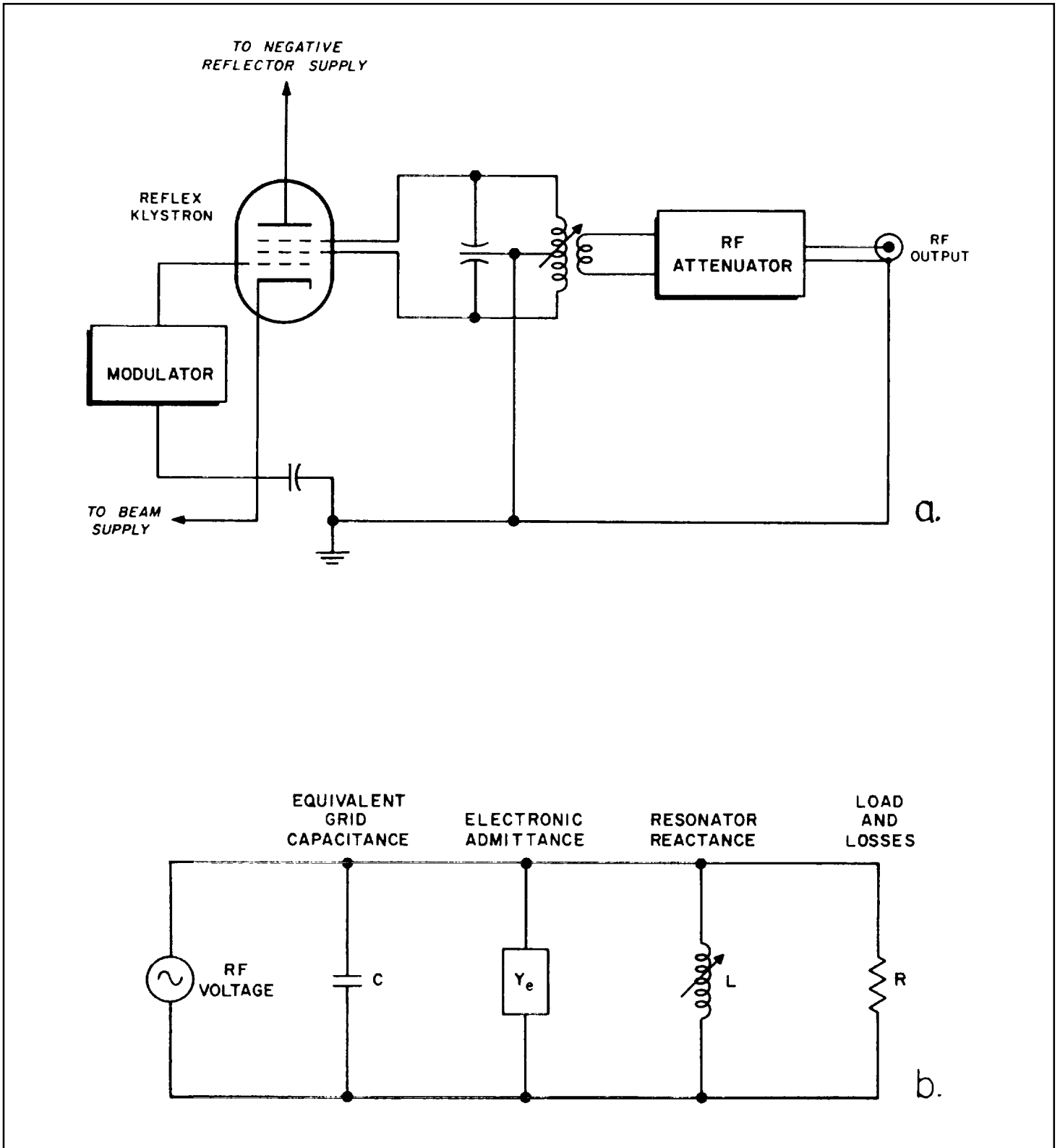

Figure 4-13. Equivalent Circuits of RF Oscillator

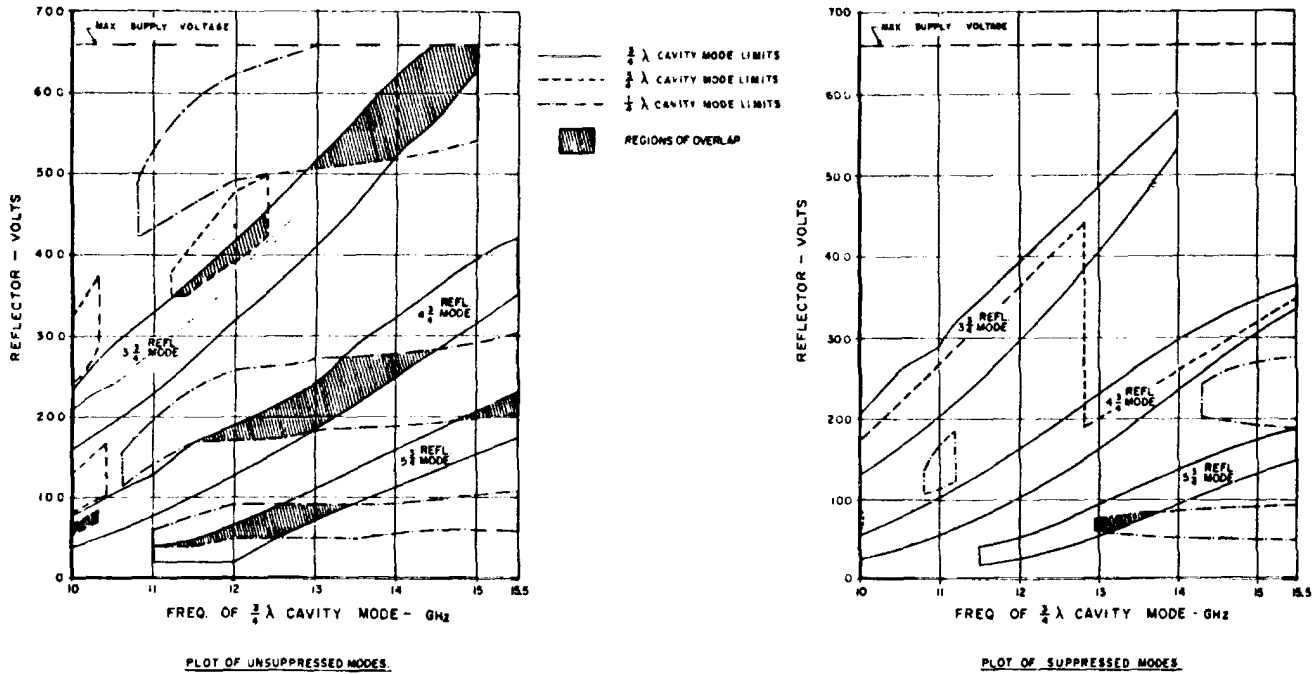

Figure 4-14. Graph Showing Klystron Oscillation Modes

4-48. As shown in the plot of modes, Figure 4-14, the 5/4 wavelength cavity mode interferes with the 3-3, reflector mode at the lower end of the band. This mode is suppressed by means of two tapered loads adjoining the cavity, parallel to the plunger, and by an adjustable load in the klystron cavity. The mode suppressors are shown in Figure 5-13. Since klystrons possess a natural tendency to oscillate on the 1/4 wavelength cavity mode, and since this mode is undesirable, it is suppressed by the use of a small cylindrical load coupled to the cavity; a small screw matches the cavity to this load. The matching screw is effectively shorted out of the circuit at approximately 11 GHz and below by a shorting switch actuated by a cam on the frequency-drive shaft (Figure 5-13).

4-49. Voltage is applied to the klystron reflector from variable resistor R96. The movable arm of R96 is ganged to the frequency drive in such manner that voltage on the reflector is automatically tracked with frequency in the desired reflector mode.

4-50. POWER-MONITOR SECTION.

4-51. The power-monitor section monitors the RF power level at the input to the calibrated attenuator (OUTPUT ATTEN DBM). The power-monitor section includes an uncalibrated attenuator (PWR SET) which adjusts the level of power applied to the calibrated attenuator, and a thermistor bridge which monitors the power applied to the calibrated attenuator. Refer to Figure 4-15.

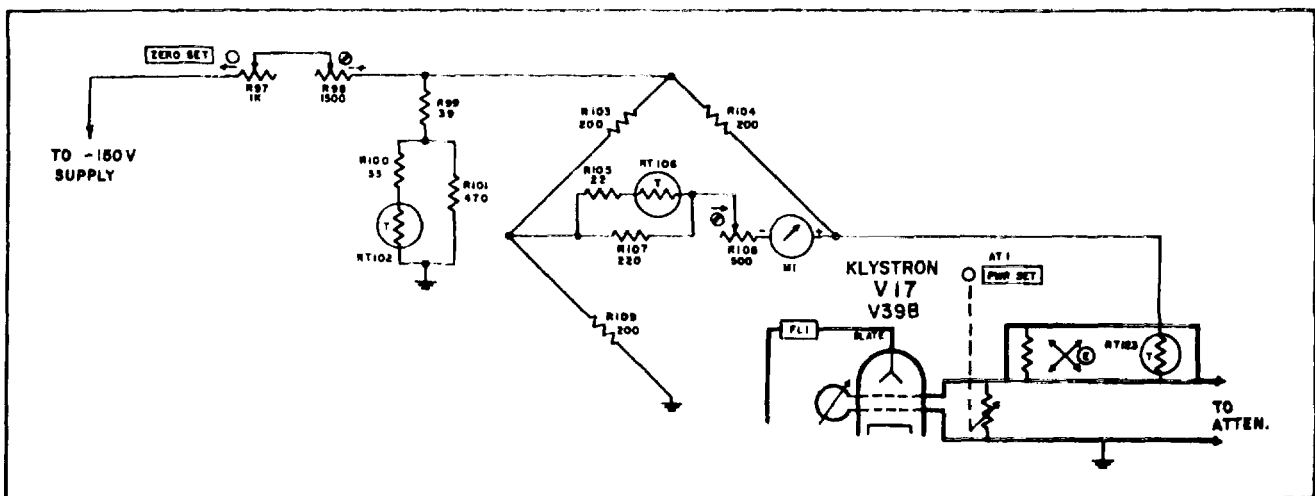

Figure 4-15. Power-Monitor Section

Section IV

4-52. RF power from the klystron is coupled to the uncalibrated attenuator which is brought out to the front panel as the PWR SET control. Power from the uncalibrated attenuator is coupled directly to the calibrated attenuator. Power delivered to the calibrated attenuator is sampled by a specially designed directional coupler and applied to one leg of the temperature compensated thermistor bridge (RT123). Power monitor meter M1 is connected across the bridge and when the bridge is balanced the meter reads ZERO SET. To bring the bridge into balance adjust the ZERO SET control. If the bridge is balanced before the power is sampled and when the sampled power causes the meter to read 0 dBm, the power level at the input to the calibrated attenuator is + 10 dBm (10 mW).

4-53. Thermistor RT106 connected in series with the meter acts as a sensitivity regulating device, necessary because of the characteristic of thermistor bridges to increase in sensitivity as the ambient temperature increases. Thermistor RT102 in the network shunted across the bridge is a temperature-compensating device. Since RT123 is temperature sensitive, the bridge could drift appreciably from its zero setting with changes in ambient temperature. RT102 compensates for this tendency. With changes in the voltage across the bridge, current through thermistor RT102 also changes, and its resistance varies in such manner as to regulate the current through RT123. The regulation of current through RT123 tends to keep the bridge in balance by counteracting any change in current through RT123 due to ambient temperature changes. Thus the bridge can be zero-set and will remain in balance to a relatively high degree.

4-54. OUTPUT ATTENUATOR SECTION.

4-55. The output attenuator section consists essentially of two broadband, precision waveguide attenuators operating in series and ganged to the OUTPUT ATTEN DBM control. The OUTPUT ATTEN is calibrated to read the output in dBm.

4-56. Each attenuator consists of three sections of waveguide in tandem. In each section a resistive film is placed across the guide as shown in Figure 4-16. The middle section is a short length of round guide which is free to rotate axially with respect to the two

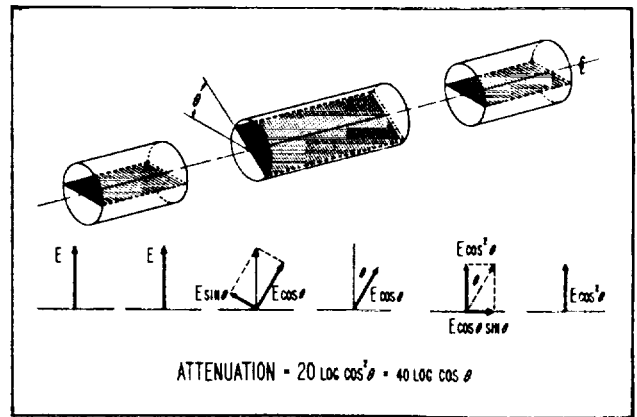

Figure 4-16. Phantom View Showing Output Attenuator

fixed end sections. The end sections are rectangular to round waveguide transitions in which the resistive films are normal to the E field of the applied wave. The construction is symmetrical.

4-57. When all films are aligned, the E field of the applied wave is normal to all films and no attenuation occurs. When the center section is rotated through an angle θ , the E field may be considered as resolved into two components: $E \sin \theta$ in the plane of the film and $E \cos \theta$ normal to the plane. The $E \sin \theta$ component will be absorbed by the film while the $E \cos \theta$ component, now oriented at an angle θ with respect to the applied wave, will be passed unattenuated to the third section. When it encounters the third film, the $E \cos \theta$ component will be split into two components: the $E \cos \theta \sin \theta$ component which will be absorbed by the film, and the $E \cos^2 \theta$ component which will emerge with orientation identical to the original wave.

4-58. The attenuation is thus a function only of the angle to which the center section is rotated and is almost completely independent of frequency. In terms of dB the attenuation is equal to $40 \log \cos \theta$. Attenuation through both attenuator sections in series is twice the attenuation through one of them, i.e. $[2 (40 \log \cos \theta)]$, and attenuation up to 100 dB may be introduced.

**SECTION V
MAINTENANCE****5-1. INTRODUCTION.**

5-2. This section provides maintenance and service information for the Model 626A SHF Signal Generator. The section includes recommended test equipment, replacement procedures for tubes, repair and adjustment procedures, and troubleshooting charts. Also included are performance checks which verify proper instrument operation.

5-3. CLEANING THE AIR FILTER.

5-4. The air filter for the Model 626A is located behind the louver on the front panel. Inspect the air filter regularly, and clean it before it becomes dirty enough to restrict air flow. To remove and clean the air filter, proceed as follows:

- a. Remove filter from instrument front panel by removing the four machine screws at the corners.
- b. Wash filter in warm water and detergent.
- c. Dry filter thoroughly and coat it with filter adhesive. We recommend Super Filter Coat from Research Products Corporation. This adhesive comes in a convenient spray can and is available from most heating supply stores or from your authorized Hewlett Packard sales representative HP Part No 3150-0002).

5-5. TEST EQUIPMENT.

5-6. Test equipment required for use in maintaining and checking performance of the Model 626A is listed in Table 5-1. Equipment having similar characteristics can be substituted for the equipment listed.

5-7. TROUBLESHOOTING.**5-8. LOCATING TROUBLE.**

5-9. Always start locating trouble with a thorough visual inspection for burned-out or loose components, loose connections, or any condition which suggests a source of trouble. Check tubes for open filaments by touching tubes and replace all that are cold. Replacing a cold tube, in most cases, will restore the generator to normal operation. Check the fuse to see that it's not open.

5-10. If trouble cannot be isolated to a bad component by a visual inspection or a cold tube, the trouble should then be isolated to a circuit section. Isolation to a circuit section can best be accomplished by using block diagram, Figure 4-2.

5-11. TROUBLESHOOTING CHARTS.

5-12. Troubleshooting charts, Table 5-2, Table 5-3, and Table 5-4, list checks and symptoms, possible causes, and remedies of various troubles. The power supply should be checked first; refer to paragraph 5-14.

5-13. For simplification, only tubes are referenced in the troubleshooting charts, but it should be remembered that components associated with referenced tubes are also failure possibilities. When testing the signal generator it is recommended that line voltage be applied through a variable transformer, and that the transformer be adjusted to deliver a voltage at the low end of the rated 103 to 127-volt range. An instrument in good condition should operate satisfactorily from any line voltage within the rated range, but where there is marginal operation (from weak tubes, etc), weaknesses become easier to trace at low line voltages.

5-14. POWER SUPPLY.

5-15. Correct operation of the power supply is vital to proper operation of the signal generator. Noise or variation in the regulated voltages causes other circuits to operate in a random or erratic manner. It is advisable to make a voltage check of the power supply whenever the instrument is suspected of marginal operation. This eliminates factors such as low voltages or poor regulation which cause unsatisfactory performance in other sections of the instrument.

5-16. The power supply section consists of three interdependent electronically-regulated voltage supplies, furnishing -300, -700, and -1250 volts as measured from chassis ground and an unregulated supply furnishing - 210 volts.

a. The -300 volt regulated supply furnishes voltage for operation of the pulse generator. It also furnishes a regulated 150 volts for the power monitor bridge. This voltage is taken from an additional voltage regulator tube (V3), included between chassis ground and the -300 volt supply.

b. The -400 volt regulated supply, stacked with the -300 volt supply, furnishes -700 volts (beam supply) to the klystron cathode and pulse circuits.

c. The -550 volt regulated supply, stacked with the -300 and -400 volt supplies, furnishes -1250 volts (reflector supply) to the klystron reflector.

5-17. The separate supplies and their relationships are shown in a block diagram, Figure 5-1. The regulated supplies are stacked, and voltage regulator tube V7 in the 550 volt supply furnishes the reference voltage for the whole supply.

5-18. After the instrument is turned on, there is a 30-second delay before the -300 and -400 volt supplies are energized, which permits tube filaments to heat before klystron beam voltage and tube potentials are applied. Thermal relay K1 in the power supply input holds the transformer T1 primary circuit open for 30 seconds after power is applied.

Table 5-1. Required Test Equipment

Instrument Type	Required Characteristics	Use	Recommended Model
Oscilloscope	Internal Sweep: 0.5 μ sec/cm to 100 μ sec/cm	Signal tracing, calibration and performance checks	HP Model 160B
Audio Oscillator	Frequency Output: 1000 Hz	Calibration	HP Model 200AB
Pulse Generator	Pulse Duration: 5 μ sec Output Voltage: 5 volts peak Repetition Rate: 4000 pps	Adjustments	HP Model 212A
Vacuum Tube Voltmeter	AC Voltage Range: 1 mV to 10 volts DC Voltage Range: to 700 volts positive and negative	General purpose and adjustments	HP Models 400D/H and 410B
Microwave Power Meter	Power Range: to 10 mW Scale to read in dBm and milliwatts	Adjustments and performance checks	HP Model 430C
Crystal Detector	Sensitivity: 0.05 V/mW Frequency Response: ± 2 dB Frequency Range: 10 to 15.5 GHz	Signal tracing, calibration and performance checks	HP Models M421A and P421A
Thermistor Mount	Power Range: to 10 mW Frequency Range: 10 to 15.5 GHz	Adjustments, calibration and performance checks	HP Models M487B and P487B
Frequency Meter	Dial Calibration Accuracy: 0.07% Frequency Range: 10 to 15.5 GHz	Calibration and performance checks	HP Models M532A and P532A

Table 5-2. Power Supply Troubleshooting

Symptom	Possible Cause	Remedy
<u>-550 VOLT SUPPLY</u>		
With voltmeter common lead connected to -700 volt terminal, connect positive lead to -1250 volt terminal to read -550 volts.		
Small deviation	Out of adjustment	Adjust R28 (Fig.5-2) to -550 volts
Low voltage	Defective series regulator V5 Defective rectifier diode	Replace V5; adjust R28 above Replace CR12, 13, 14, or 15; adjust R28 above
High voltage	Defective control tube V6	Replace V6; adjust R28 above
Erratic voltage	Defective reference tube V7	Replace V7; adjust R28 above
<u>-400 VOLT SUPPLY</u>		
With voltmeter common lead connected to -700 volt terminal, connect positive lead to -300 volt terminal to read +400 volts.		
Low voltage	Defective series regulator V1 Defective rectifier diode	Replace V1 Replace CR6, 7, 8, or 9
High voltage	Defective control tube V4	Replace V4
<u>-300 VOLT SUPPLY</u>		
With voltmeter common lead connected to -700 volt terminal, connect positive lead to chassis ground to read +700 volts.		
Low voltage	Defective series regulator V1 Defective rectifier diode	Replace V1 Replace CR2, 3, 4, or 5
High voltage	Defective control tube V2	Replace V2
<u>-150 VOLT BRIDGE SUPPLY</u>		
Connect voltmeter terminals between chassis and pin 2 of V3 to read -150 volts.		
Voltage unstable	Defective V3 Defective -300 volt regulation	Replace V3 Adjust -300 volt supply

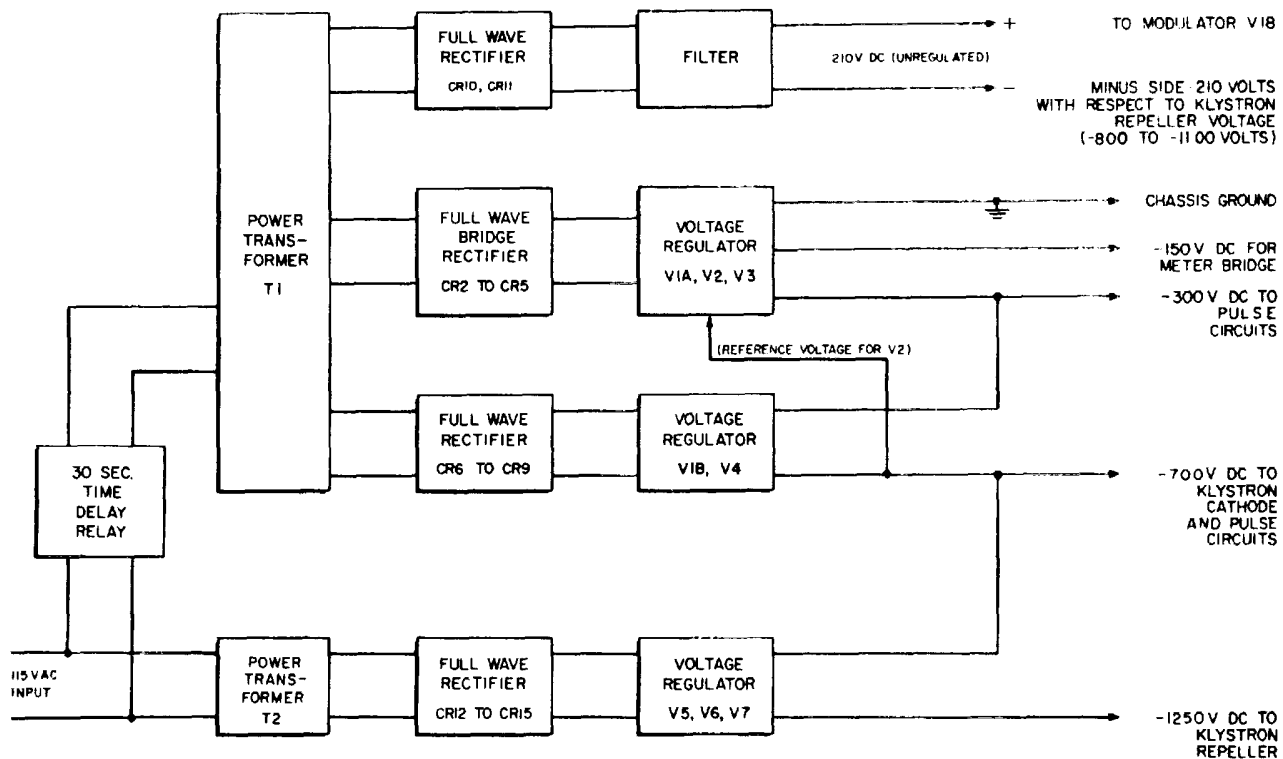

Figure 5-1. Block Diagram of Power Supply

5-19. It will be noticed in the schematic diagram a the power supply, Figure 5-20, that V6, the control tube for the -700 volt supply, has a divided plate load consisting of R21 and R25-R26. R21 acts as the plate load before the thermal relay is actuated while R25 R26 act as the plate load after the relay trips.

5-20. When measuring voltages in power supply, the procedure given in Table 52 should be followed. This permits the voltmeter common to be attached to -70(volt bus at all times, while the dc probe is moved from point to point. Use of polarity switch on the voltmeter will be required only when measuring +700 and +40C volts to chassis ground.

WARNING

When measuring voltages from points on the regulator card which have dc potential to ground, use a plastic encased multimeter. When using metal case vtm's exercise great care since metal cabinets will beat high negative potentials.

5-21. Adjust line voltage from 103 to 127 volts while measuring output voltages from the regulated supply The regulated voltages may vary +1% with this line voltage change.

5-22. REPAIR.

5- 23. CABINET REMOVAL.

5-24. To remove Model 626A from its cabinet proceed as follows:

- a. Position instrument so that it is resting on front panel guard rail handles.
- b. Remove four screws on the back of the cabinet, and lift the cabinet from instrument chassis.

5-25. TUBE REPLACEMENT CHART.

5-26. Tubes used in Model 626A are listed in Table 5-5. Any tube may be replaced with a tube having corresponding RETMA standard characteristics. When tube replacement requires that an adjustment be performed, Table 5-5 references paragraph or table where pertinent adjustment information is given. It is recommended that tubes be checked by substituting new tubes of the same type; if no improvement in performance is noted, return original tube to the socket.

5-27. SERVICING ETCHED CIRCUIT BOARDS.

5-28. To service etched circuit boards the following steps are recommended.

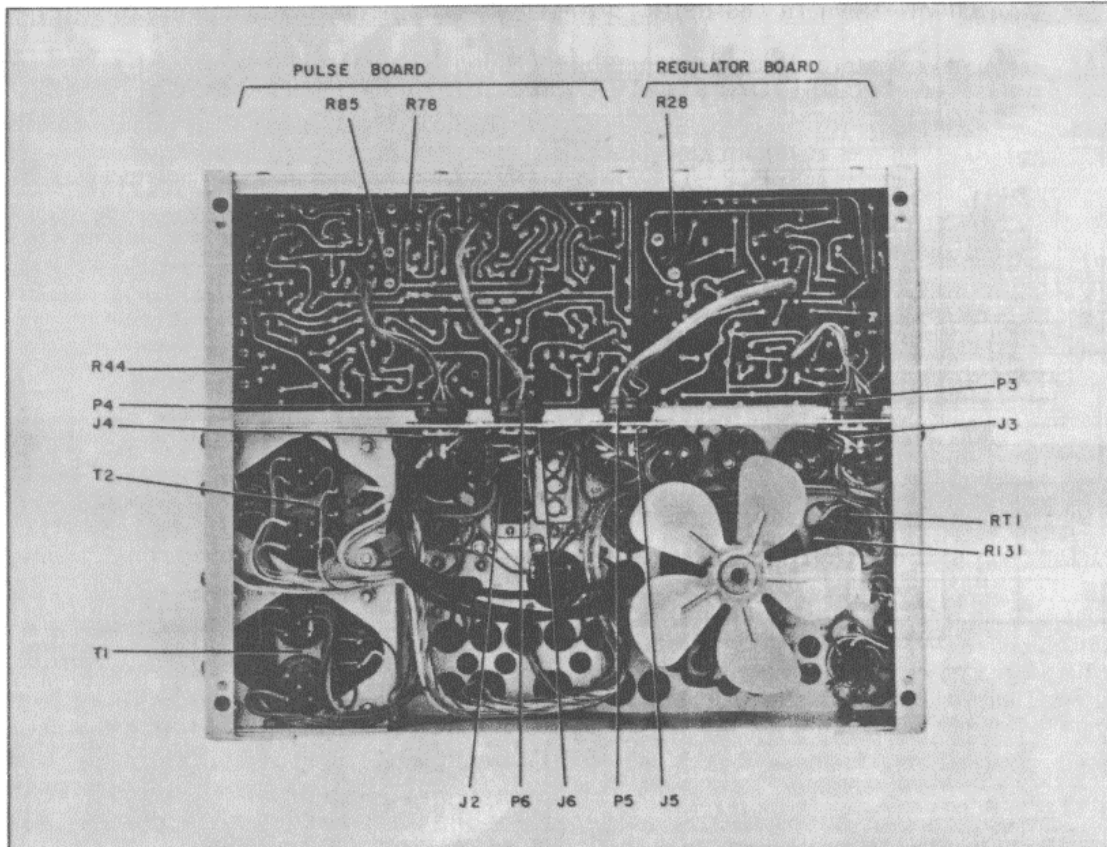

Figure 5-2. Rear View of Instrument Showing Power Supply and Pulse Sections

Table 5-3. RF Generator Troubleshooting

Symptom	Possible Cause	Remedy
With MOD SELECTOR set to OFF Power- monitor meter not indicating	No supply voltage	Measure bridge supply voltage across end tap (orange lead) R98 (Figure 5-7) and ground; should be approximately 2 to 3 volts. Check -150 volt supply.
	Defective VR tube V3	Replace V3; readjust ZERO SET (para 5-41)
Power- monitor meter pins upscale or downscale	Open meter	Disconnect meter; check continuity. Caution: 200 μ A movement
	Shorted or open component on one side of bridge causing unbalance	Disconnect one side of meter. Measure bridge supply voltage at R98 (see remedy step above) for 2 to 30 volts. Measure voltage between each side of bridge and ground to determine side at fault. The voltage at both midpoints on each side of the bridge should be 1/2 voltage applied to bridge from R98.
Power- monitor meter pins to left below zero	Open thermistor RT123	Replace thermistor mount. Recalibrate power- monitor meter (para 5-59)

Table 5-3. RF Generator Troubleshooting (cont'd)

Symptom	Possible Cause	Remedy
With MOD SELECTOR set to OFF (cont'd) Power- monitor meter pins to right upscale	High bridge voltage; defective VR tube V3 Shorted thermistor mounting-post insulator. (One post is insulated from mounting by mica washer which also acts as bypass capacitance.)	Replace V3 It is recommended that entire mount be replaced because of difficulties in adjusting mount frequency response after reinsulating post (para 5-59)
With MOD SELECTOR set to CW Power- monitor meter indicates weak output	Incorrect tracking adjustments Defective klystron Extraneous material in cavity (braid, filings, polyiron chips, etc)	Check reflector tracking adjustments (para 5-50). Observe mode patterns. Replace klystron, cavity, and frequency drive mechanism (para 5-29) Remove foreign matter

- a. Do not apply excessive heat.
- b. Remove a damaged component by clipping leads near component.
- c. Apply heat to component lead and remove lead with a straight upward pull.
- d. Use a toothpick or wooden splinter to clean holes.

- e. Solder replacement components from the conductor side.

5-29. KLYSTRON TUBE REPLACEMENT.

5-30. If it is necessary to replace the klystron tube, the klystron cavity and frequency drive mechanism must be replaced as a unit. Replacement unit (HP Part No. 626A-95A) consists of a new klystron installed in

Table 5-4. Pulse Section Troubleshooting

Symptom	Possible Cause	Remedy
No RF output with MOD SELECTOR set to INT or SQ WAVE. INT FM and CW positions satisfactory	Defective V8, V9, or V10 Schmitt trigger sensitivity out of adjustment	Replace; see Table 5-5 Adjust R44; see para 5-43
No RF output with MOD SELECTOR set to INT and no SYNC OUT or DELAY SYNC OUT pulses. SQ WAVE position satisfactory	Defective V11	Replace; see Table 5-5
No RF output with MOD SELECTOR set to INT and no DELAY SYNC OUT pulse. SYNC OUT pulse and SQ WAVE positions satisfactory	Defective V12, V13, V14 Min. delay adj. misadjusted	Replace; see Table 5-5 Adjust R78; see para 5-57
No RF output with MOD SELECTOR set to INT. SYNC OUT pulse, DELAY SYNC OUT pulse and SQ WAVE positions satisfactory	Defective V15 Min. width adj. misadjusted	Replace; see Table 5-5 Adjust R85; see para 5-58
No RF output with MOD SELECTOR set to INT or SQ WAVE. SYNC OUT pulse, DELAY SYNC OUT pulse and INT FM and CW positions satisfactory	Defective V18	Replace; see Table 5-5

Section V

Table 5-5. Tube Complement

Tube	Type	Function	Adjustment Reference
V1	6080	Series Regulator (-300 volt supply and -400 volt supply)	Table 5-2
V2	6AU6	Control Tube(-300 volt supply)	Table 5-2
V3	OA2	Voltage Reference Tube (-150 volts) PWR SET bridge supply	Paragraph 5-59
V4	6AU6	Control Tube (-350 volt supply)	Table 5-2
V5	6AQ5	Series Regulator (-550 volt supply)	Table 5-2
V6	6AU6	Control Tube (-550 volt supply)	Table 5-2
V7	5651	Reference Tube (- 550 volt supply)	Table 5-2
V8	6AL5	Clamping Diode	No adjustment required
V9	12AT7	Pulse Rate Multivibrator and Input Squaring Amplifier	Paragraph 5-55
V10	12AT7	Schmitt Trigger	Paragraph 5- 43
V11	2D21	Sync Out Thyatron	No adjustment required; selection may be necessary, however.
V12	6AL5	Clamping Diode	No adjustment required
V13	12AT7	Pulse Delay Multivibrator	Paragraph 5-57
V14	2D21	Delayed Sync Out Thyatron	No adjustment required
V15	12AT7	Pulse Width Multivibrator	Paragraph 5-58
V16	6X4	Limiting Diode	No adjustment required
V17	V39B	Klystron Oscillator	Paragraph 5-45
V18	5687	Modulator	No adjustment required

a cavity which is attached to the associated frequency drive mechanism. A new calibrated frequency dial also included with the unit. Units are completely pre-tested and adjusted at the factory. Field installation of the replacement unit is simple and requires no extensive readjustment procedure. Units can be obtained from the factory on an exchange basis by contacting the nearest Hewlett-Packard field representative or factory service department.

CAUTION

THE STOPS FOR THE FREQUENCY DRIVE MECHANISM ARE INOPERATIVE WHEN FREQUENCY DIAL IS NOT IN PLACE. ROTATING THE SHAFT FOR THE FREQUENCY DIAL AND FREQUENCY DRIVE CAM TO ONE EXTREME OR THE OTHER WITHOUT THESE STOPS MAY RESULT IN SERIOUS AND PERMANENT DAMAGE TO PLUNGERON INNER END OF FREQUENCY DRIVE ROD. HANDLE WITH CARE.

5-31. PRIOR TO REMOVAL. Before removing klystron cavity and frequency drive mechanism, the PW SET attenuator must be withdrawn from klystron cavity; failure to do this will result in a broken attenuator. To prevent damage to attenuator, proceed as follows:

- a. Rotate PWR SET maximum clockwise.
- b. In Figure 5-10, locate power set atten. drive in upper left hand corner of picture. Loosen allen setscrews that hold large gear in attenuator drive.
- c. Locate collar on attenuator drive shaft(parallel with panel) and gently pull this collar away from large attenuator drive gear until it stops. Power set attenuator card will now be clear of klystron cavity and you may proceed with klystron removal.
- d. After klystron assembly has been installed, slide attenuator shaft back toward large drive gear making sure setscrew on collar is on top.
- e. With PWR SET maximum clockwise, press large gear and collar together with your fingers and tighten setscrews on gear.
- f. Check operation of PWR SET to make sure it operates smoothly.

5-32. REMOVAL. Refer to Figure 5-3 and proceed as follows:

- a. Obtain a scratch awl or similar sharp-pointed tool.

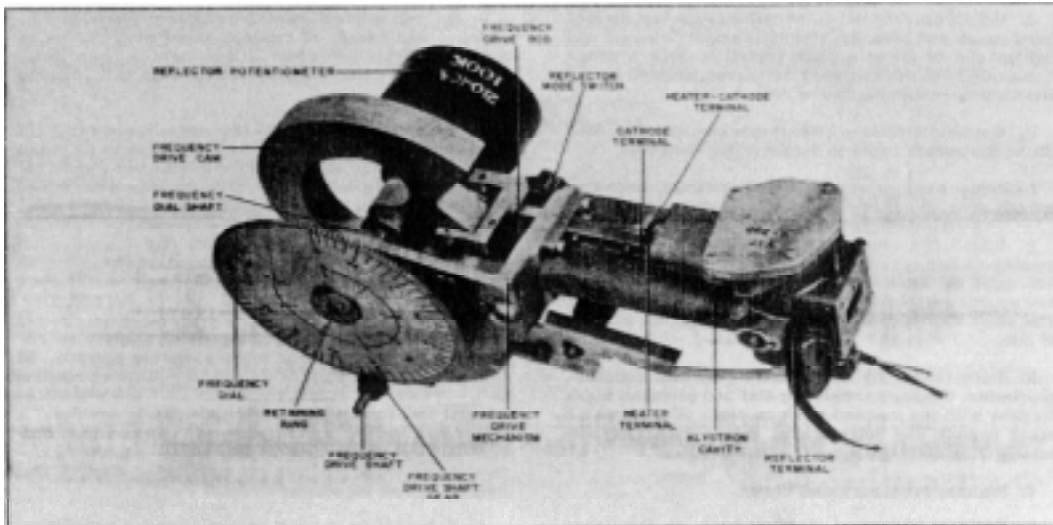

Figure 5-3. View of Klystron Cavity and Frequency Drive Mechanism

- b. Rotate frequency control full counterclockwise to stop. Normally a small dot just to the left of 10 GHz. dial point will be under the hair line.
 - c. Remove and save frequency control knob and cover over frequency dial. This cover is held in place by four screws.
 - d. With awl, mark a valley on the frequency drive shaft gear and the tooth of frequency dial which meshes in this valley.
 - e. The dial is held on frequency dial shaft by a retaining ring with four screws. Remove all four screws without permitting frequency dial to rotate with respect to shaft and hub on which it is mounted. Place a short scratch mark across shaft end, dial hub, and a short way onto dial so that all three can be replaced later in exactly the same position. This scratch mark will be found on shaft, dial hub, and dial supplied in the replacement assembly (HP Part No. 626A-95A).
 - f. Remove dial hub and spring washer over frequency dial shaft. Save spring washer for use in step f under paragraph 5-33, Installation.
 - g. Note connections to reflector potentiometer by drawing a sketch before disconnecting leads. Disconnect leads.
 - h. Remove and save three front panel screws that hold frequency drive mechanism onto rear of panel. Tip instrument forward onto guard rail handles at each end of the panel.
 - i. Remove and save tubes V16 and V18. Note connections for the four wires from klystron cavity and disconnect at terminals adjacent to V16 tube socket.
 - j. Remove and save four screws holding waveguide section to klystron cavity. Support cavity as last screw is removed to prevent damage to waveguide.
 - k. Slide klystron cavity and frequency drive assembly to left and lift cavity upward. The entire assembly will now swing to one side to expose the connections to reflector mode switch.
 - m. Note connections to reflector mode switch by drawing a sketch before disconnecting leads. Disconnect leads.
 - n. Lift entire assembly from instrument. Observe the CAUTION following para 5-30.
- 5-33. INSTALLATION. Refer to Figure 5-3, and proceed as follows:
- a. Reconnect leads to reflector mode switch. Refer to the sketch made in step m under paragraph 5-32, Removal.
 - b. Swing klystron cavity and frequency drive mechanism in place on instrument and replace the four screws (removed in step j under Removal) that fasten klystron cavity to waveguide section. Tighten all screws firmly.
 - c. Reconnect klystron leads. Refer to notes made in step I under Removal. Check connections carefully as an error may result in a burned out klystron. Replace tubes V16 and V18.

Model 626A

- d. Hold frequency drive mechanism against back of front panel and turn instrument upright. Insert and tighten one of three screws (saved in step h under Removal) that hold frequency drive mechanism. Insert and tighten remaining two screws.
- e. Reconnect leads to reflector potentiometer. Refer to the sketch made in step g under Removal. f. Replace spring washer(saved in step f under Removal) over end of frequency dial shaft.
- g. Install frequency dial hub supplied with new assembly. Align scratch marks on end of shaft and dial hub, push hub back until end of shaft and surface of hub are approximately flush. Tighten setscrews in hub. The shaft must not protrude beyond the front surface of hub.
- h. Turn frequency drive shaft gear full counterclockwise. Replace frequency dial and align the mark on gear with the marked tooth on dial. Align scratch mark across dial hub and dial before replacing retaining ring and tightening the four screws.
- i. Replace frequency dial cover.
- J. Replace frequency control knob on frequency drive shaft.
- k. Rotate frequency drive shaft full counterclockwise and hold against stop. Check that the dot on frequency dial is under the hair line.

5-34. ADJUSTMENTS. After replacing the klystron cavity the following adjustments are necessary. Refer to Figure 5-3 and proceed as follows:

- a. Connect an ac voltmeter such as an HP Model 400D/H between the heater-cathode terminal and heater terminal.

WARNING

Use an insulated voltmeter. This is necessary due to high voltages applied to the klystron tube. If the voltmeter has a ground lead be sure it is isolated by using a three-prong to two-prong adapter and leave the pigtail floating. Extreme care must be taken to insulate the metal instrument case as it will be at the same potential as the ground clip lead.

- b. Connect power cord to proper source and turn Model 626A on.
- c. The heater voltage should be 6.3 Vac. If heater voltage is not 6.3 Vac refer to paragraph 5-39.
- d. Set Model 626A MOD SELECTOR switch to INT FM.
- e. Connect an HP Model 410B VTVM positive lead to the reflector terminal and negative or common lead to the cathode terminal. Voltmeter SELECTOR switch should be set to -.

- f. Set potentiometers R89 and R95 (Figure 5-10) to approximate center of range over which they can be rotated. These two controls are located on an insulated bracket mounted on the bottom edge of modulator assembly.
- g. Set frequency dial to 10 GHz and adjust control R92 for a voltmeter reading of *___volts. Slowly increase frequency setting until the point is reached where reflector mode switch just operates as can be determined by an audible click. At this point adjust R87 for a voltmeter reading of *___volts. If either R92 or R87 have insufficient range, adjust control R95 beyond point where desired reading is obtained and then readjust the particular control that originally had insufficient range.
- h. Decrease frequency dial setting slightly as required to cause reflector mode switch to operate. At this point, adjust control R88 for a voltmeter reading of *___volts. Set frequency dial to 15.5 GHz and adjust control R93 for a voltmeter reading of *___volts. If either R88 or R93 have insufficient range, adjust control R89 beyond point where the desired reading is obtained and then readjust the particular control that originally had insufficient range.
- i. Repeat steps g and h several times as necessary. These controls all interact but if steps g and h are repeated enough times a point will be reached where additional adjustment will not be necessary.
- j. If reflector voltages are carefully set, no additional adjustments will normally be required. To check instrument performance refer to paragraph 5-62.

5-35. To better understand the relationship of parts in the klystron cavity and drive mechanism refer to Fig 5-4 and Fig 5-5.

5-36. REFLECTOR POTENTIOMETER REPLACEMENT.

- 5-37. To replace reflector potentiometer, R96, refer to Figure 5-6 and proceed as follows:
 - a. Remove power to instrument.
 - b. Draw a sketch of reflector potentiometer, R96, noting color and location of leads.
 - c. Remove leads from potentiometer.
 - d. Remove retaining ring and back of potentiometer. Remove screw holding potentiometer to supporting bracket.
 - e. Loosen setscrews on mode-switch cam located between cam and potentiometer. DO NOT LOOSEN setscrews between mode-switch cam and frequency drive casting (see Figure 5-6).

*These voltages vary from one klystron to another. Correct voltages will be specified in the instructions sent with each replacement unit.

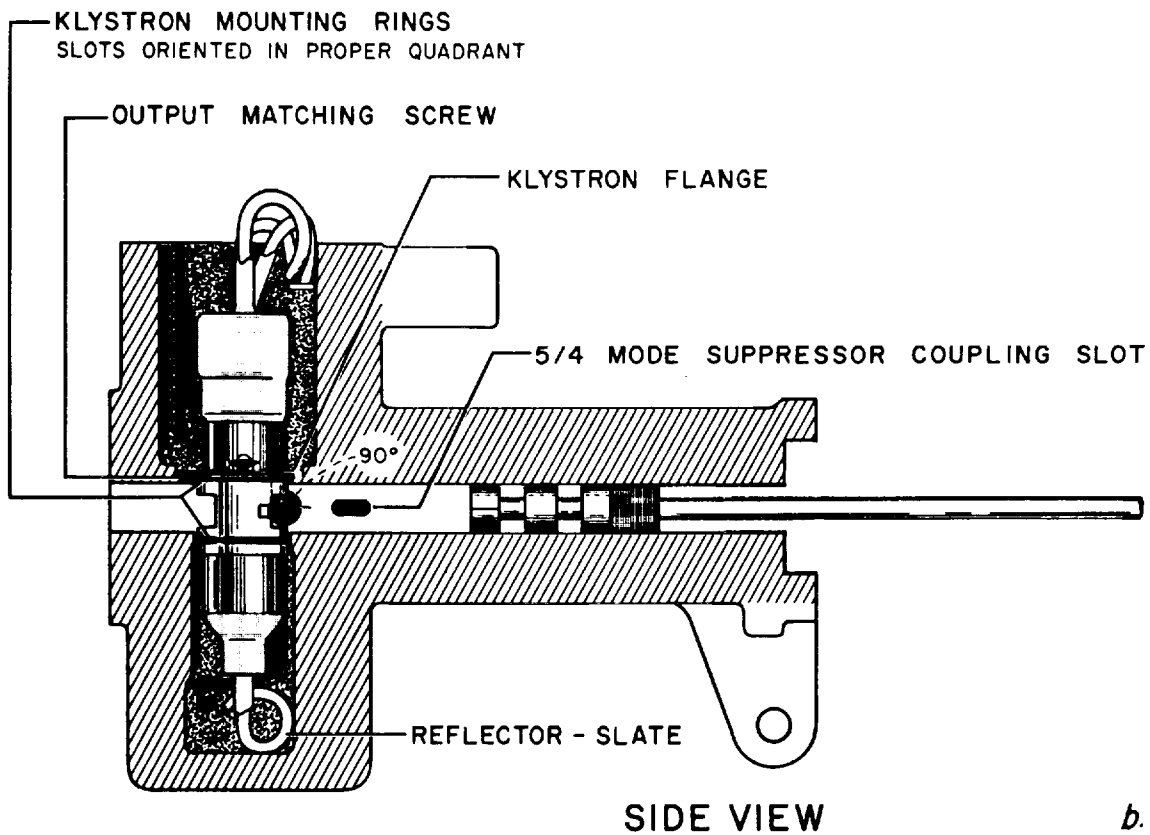
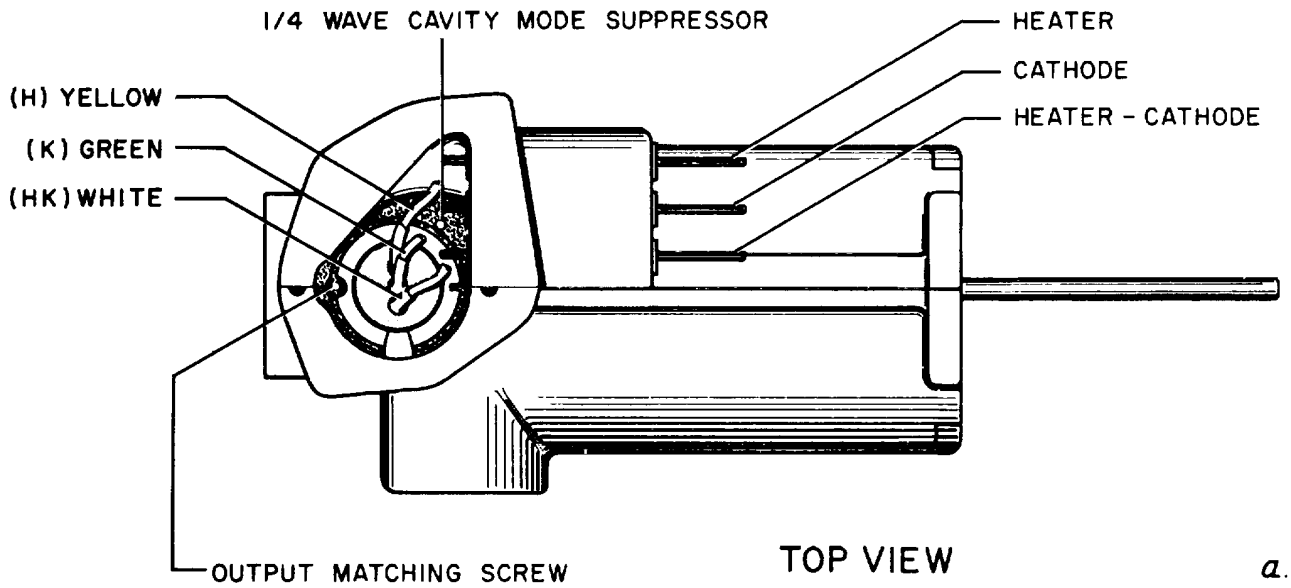

Figure 5-4. Cutaway Views of Klystron Cavity

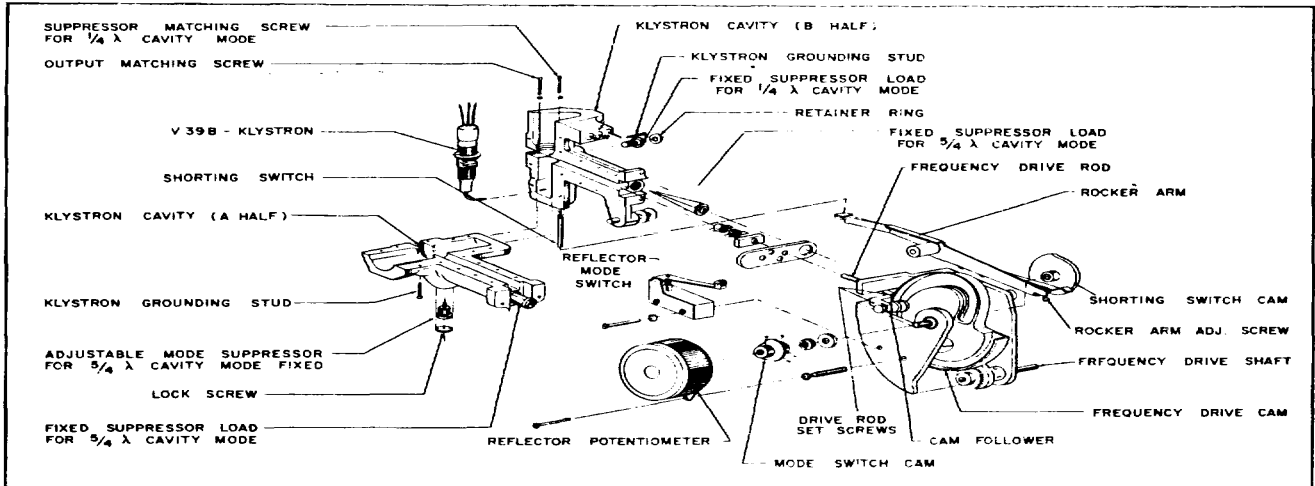

Figure 5-5. Exploded View of Klystron Cavity and Plunger Drive Mechanism

- f. Remove reflector potentiometer.
- g. Remove back from replacement potentiometer and connect it to supporting bracket with the screw removed in step d.
- h. Do not tighten mode -switch cam setscrews at this time.
- i. Refer to sketch made in step b and reconnect leads to potentiometer.
- j. Connect an ohmmeter set on the X1000 range between the center tap and wiper arm of potentiometer.
- k. Position frequency dial to point of mode- switch actuation. Move frequency dial back and forth through the mode- switch lag distance to determine mid-point. Place frequency dial at this mid-point.
- m. Hold frequency dial in place and adjust position of wiper arm inside potentiometer until ohmmeter reads minimum resistance.
- n. Tighten mode-switch cam setscrews and replace back of potentiometer.
- p. If necessary, perform reflector tracking adjustment as described in paragraph 5- 51k.

- b. Voltmeter reading should be 6.3 Vac.
- c. If voltmeter reads high, decrease shunt resistance (R131). Increase this resistance if reading is low. Continue to change this resistance until the heater voltage reads 6.3 Vac.
- d. Wait 10 minutes and repeat steps a and b. If voltmeter reading is not 6.3 vac, repeat step c.

5-38. REPLACING RT1.

5- 39. After replacing RT 1 the klystron heater voltage should be checked and adjusted if necessary. Refer to Fig 5-2, Fig 5-3, and proceed as follows:

- a. Connect an ac voltmeter such as an HP Model 400D/H between the heater-cathode terminal and heater terminal.

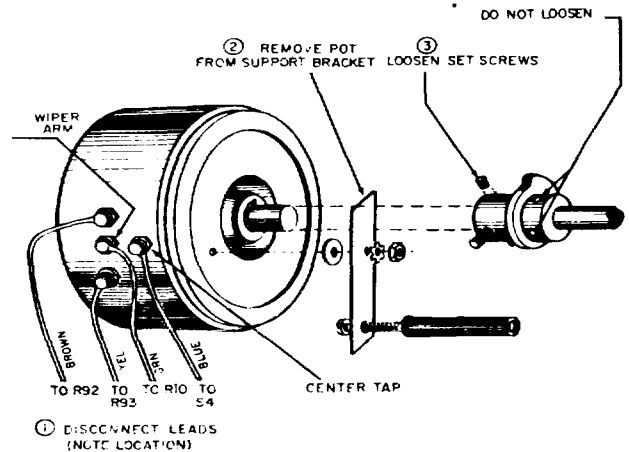

Figure 5-6. Detail Showing Reflector Potentiometer Removal

Model 26A

5-40. ADJUSTMENTS.

5-41. ZERO SET CONTROL ADJUSTMENT.

5-42. When front panel ZERO SET control will not zero-set the power-monitor meter, the range of this control needs to be extended. To extend its range, refer to Figure 5-7 and proceed as follows:

- a. Set MOD SELECTOR to OFF and position ZERO SET control to its mechanical center.
- b. Adjust R98 until power-monitor meter indicates Zero Set.

5-43. SCHMITT TRIGGER LEVEL ADJUSTMENT.

5-44. To adjust schmitt trigger level, refer to Figures 5-2, 5-10, and proceed as follows:

- a. Connect test setup as shown in Figure 5-8. Oscilloscope vertical input is to be connected to terminal B GRN on modulator board.
- b. Adjust calibrated pulse generator output for 4000 pps. Pulses should be 5 μ sec duration and 5 volts peak. For maximum accuracy, calibrate pulse generator with oscilloscope.
- c. Set Model 626A MOD SELECTOR to OFF and TM 11-6625-2910-14

- d. Adjust oscilloscope so that it is calibrated to 1 μ sec/cm.
- e. Adjust R44 until pulse duration is 5 μ sec.

5-45. ADJUSTMENTS FOLLOWING KLYSTRON REPLACEMENT.

5-46. Following replacement of a new klystron (tube only) certain adjustments must be made before the instrument will operate in a satisfactory manner. The general steps in the overall procedure are as follows:

- a. Establish initial reflector tracking voltages.
- b. Partial reset of frequency dial.
- c. Suppress undesired modes of oscillation, fineadjust frequency dial and fine-adjust reflector tracking.
- d. Output power response adjustment.

5-47. INITIAL REFLECTOR-VOLTAGE ADJUSTMENTS.

- a. Check all power supply voltages as indicated in Table 5-2.
- b. Reflector voltages can now be set, as described in paragraph 5-49, to values given on the data sheet

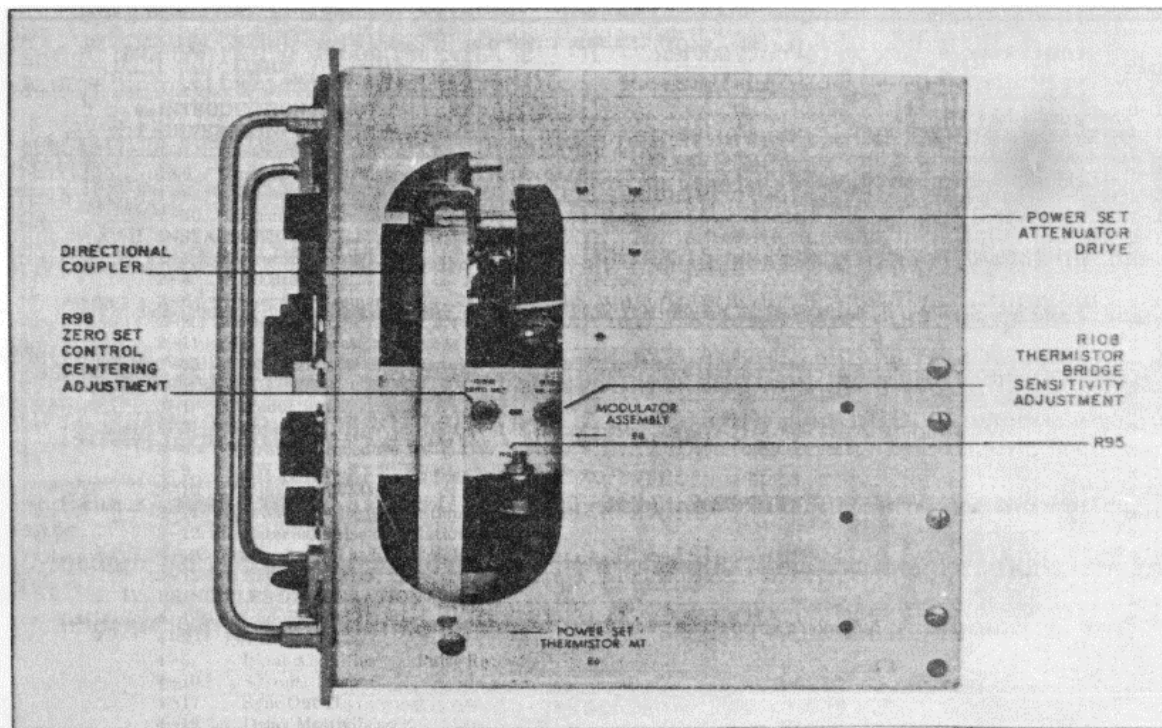
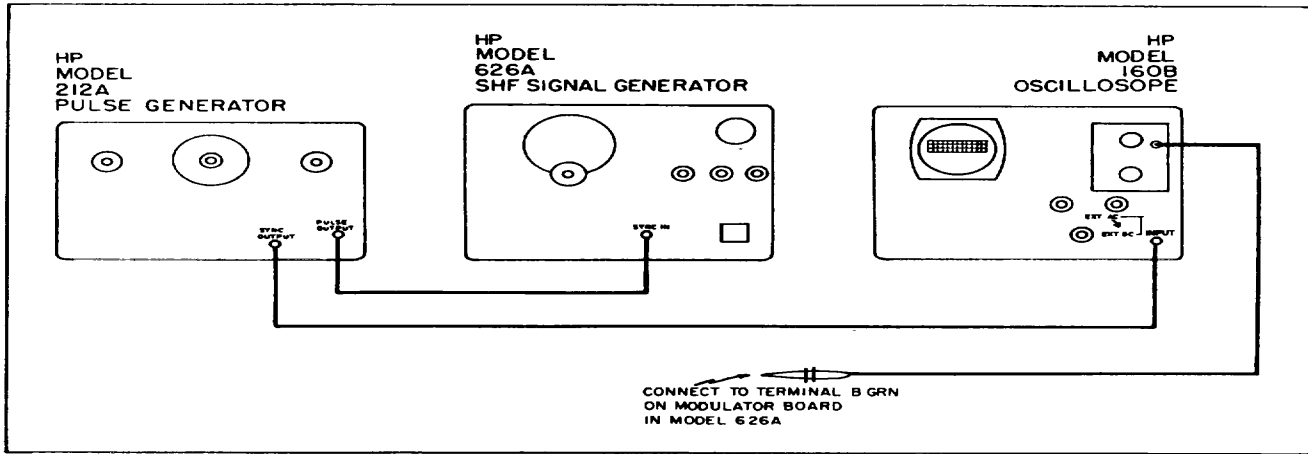

Figure 5-7. Right Side View Showing Power Monitoring Bridge Adjustment



Model

Section V

Figure 5-8. Test Setup for Observing Reflector Modes

supplied with the replacement klystron. Voltages are most easily measured at klystron terminal strip located on the modulator deck. There are four terminals marked K, H, H, R. Cathode-to-reflector voltage is measured between terminals K and R. The frequency at which each reflector tracking potentiometer is adjusted is shown in Figure 5-9.

Note

A data sheet supplied with the replacement klystron tabulates reflector (reflector-to cathode) voltage vs frequency. The klystron manufacturer tests the tube under slightly different operating conditions from those in the instrument, but voltages are close enough to be useful when making tracking adjustments. It should be mentioned that while voltages given at 10 GHz and 15.5 GHz are directly applicable, the klystron manufacturer switches from 3-3/4 reflector mode to 4-3/4 reflector at a frequency (generally 13.5 GHz) which varies slightly from that at which the instrument switches (generally 12.8 GHz). Voltages specified in the data sheet should be used however, and (R87 or R88) adjusted above and below the instrument mode switching point. (This is proper practice since adjustment pots are designed to adjust voltages at the high and low frequency sides of specific modes rather than at specific frequencies.) The setting obtained this way will be close enough for initial tracking.

WARNING

When measuring reflector-to-cathode voltage the reflector should be negative with respect to the cathode by the voltage shown in the data sheet. Use extreme care when measuring this voltage since it is 1200 volts negative with respect to instrument chassis.

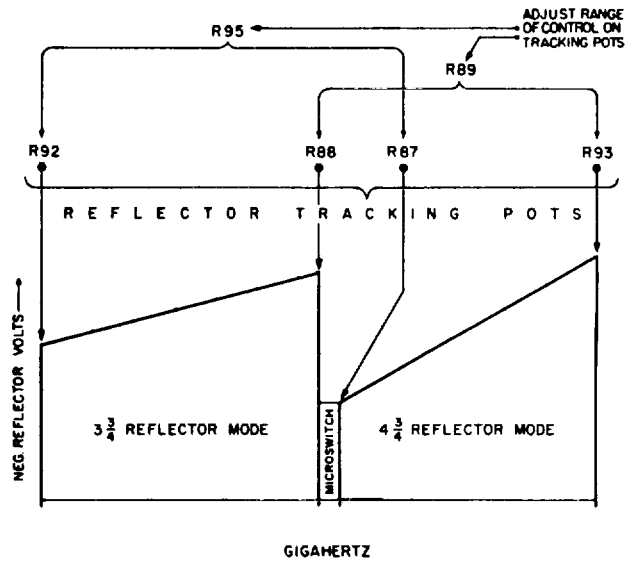

Figure 5-9. Graph Showing Reflector Tracking Voltage vs Frequency

5-48. INITIAL TRACKING PROCEDURE. Refer to Figure 5-10 and proceed as follows:

Model 626A

- a. Set R95 and R89 to mechanical center of rotation.
- b. Connect voltmeter common to klystron terminal K, and connect positive lead to klystron terminal R. Set frequency dial to 10GHz and adjust R92 (and R95 if necessary) to read tabulated voltage for 10 GHz point.
- c. Set frequency dial to point near 12.8 GHz just before microswitch actuates. Adjust R88 (and R89 if necessary) to read tabulated voltage for 3- 3/4 reflector mode high frequency point.
- d. Set frequency dial to point near 12.8 GHz just after microswitch actuates. Adjust R87 to read tabulated voltage for low frequency point of 4- 3/4 reflector mode.
- e. Set frequency dial to 15.5 GHz and adjust R93 to read tabulated voltage for 15.5-GHz point.

f. When voltages are correct, remove power from instrument and connect klystron heater and cathode leads as shown in Figure 5-4a.

5-49. INITIAL FREQUENCY SETTING.

- a. Turn Model 626A on and check klystron heater voltage (paragraph 5- 39).
- b. Set Model 626A controls as follows:

MOD SELECTOR.....	INT FM
OUTPUT ATTEN.....	+10 DBM
FM AMPLITUDE.....	full clockwise
frequency dial.....	15.5 GHz

- c. Connect test setup as shown in Figure 5-11, and check for output.

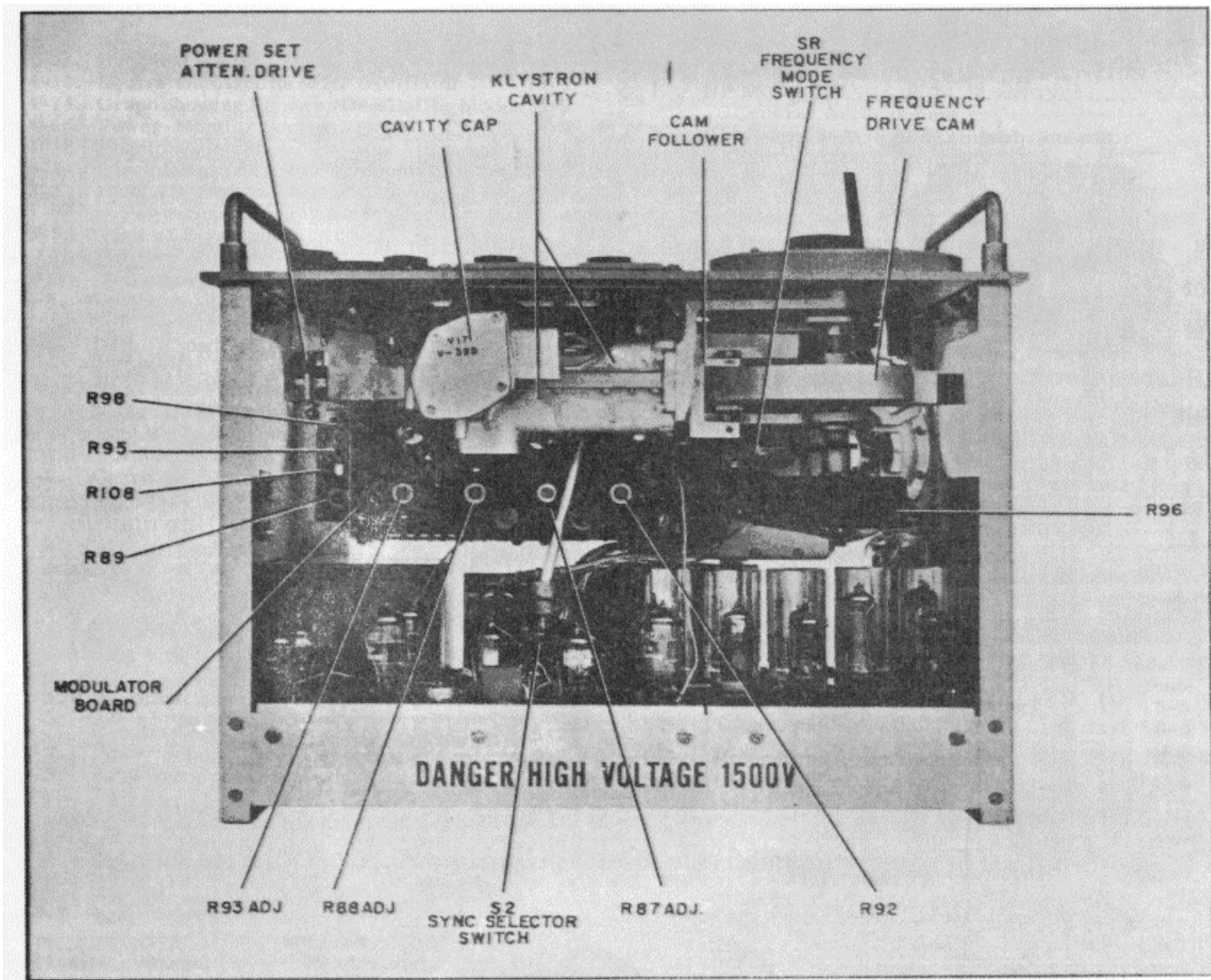

Figure 5-10. Top View Showing Location of Reflector Tracking Pots

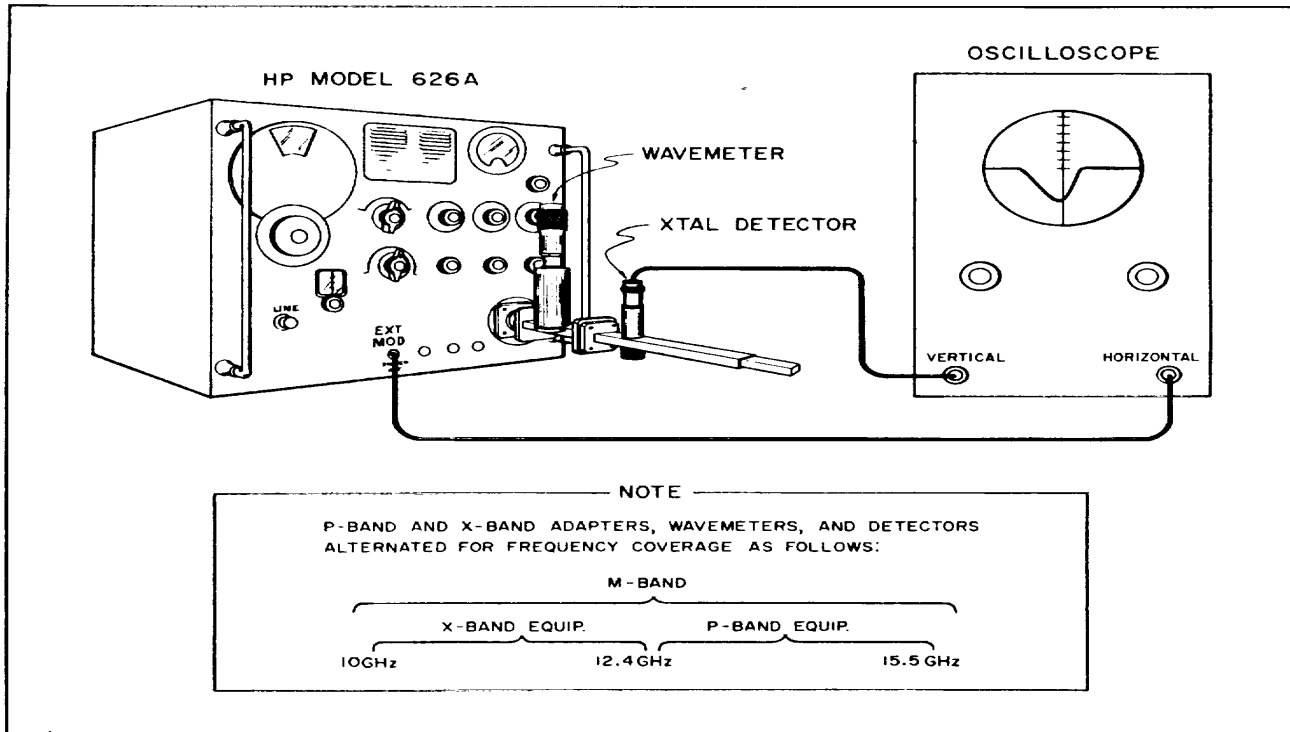

Figure 5-11. Test Setup for Observing Reflector Modes

Note

The test setup shown in figure 5-11 with control settings on the signal generator described in step b permits the Model 626A to internally FM the klystron with a 60-Hz sine wave of sufficient amplitude to drive the klystron in and out of oscillation (see paragraph 3-13). When an oscilloscope is connected, its horizontal sweep circuit is driven by 60 Hz synchronized with the 60-Hz sine wave frequency modulating the reflector. Vertical trace is driven by detected output from klystron. As klystron passes in and out of oscillation a humped waveform will appear on the oscilloscope. The hump is an indication of klystron output amplitude vs reflector voltage and may be construed as the reflector mode for frequency of oscillation. Typical mode pattern oscillograms appear in Figure 5-12.

d. Adjust oscilloscope to center horizontal trace for equal deflection on each side of vertical scale center.

e. Adjust FM PFASE for optimum presentation of mode pattern at 15.5 GHz. It may be necessary to bring crest of the mode pattern closer to the oscilloscope vertical centerline with R93 in order to produce satisfactory output, but such a tracking adjustment is not critical at this stage of alignment as long as significant output is available at extremes of the band. If voltages have been set according to klystron manufacturer's data sheet, adequate output should be available, barring such considerations as a weak klystron or improper seating in cavity.

f. Set frequency dial near high frequency end. Where plunger rod is accessible, loosen setscrews holding plunger rod to cam follower (refer to Figure 5-5).

WARNING

When loosening setscrews holding plunger rod to cam follower, extreme care should be used as microswitch (located near cam follower) has high negative voltages on it.

Model 626A

g. Pull plunger rod out of cavity until it hits frequency drive cam. Tighten lightly side setscrew holding plunger rod to cam follower.

h. Set frequency dial to 15.5 GHz (changing wavemeters and detector mounts if necessary) and set wavemeter to 15.5GHz. Loosen setscrew holding plunger rod.

i. With a thin-pointed tool, push plunger rods lightly into the cavity until wavemeter notch appears on mode pattern. Tighten one setscrew lightly which holds plunger rod to cam follower.

Note

The purpose of adjustments in step i (adjusting plunger rod) and in step m (adjusting cam) is to adjust the length of plunger travel against length of dial travel from the low end of the band to high end of the band. These adjustments interact, but by repeated adjustments of the cam at 10 GHz and plunger rod at 15.5 GHz, the ends of the dial may be brought into calibration. DO NOT loosen frequency dial hub-screws or otherwise attempt to calibrate the dial by slipping it at the hub.

j. Repeat steps e through h to obtain approximate dial calibration at the end of the band. Final calibration is made between mode suppression and fine tracking adjustments.

k. Set 10 GHz on wavemeter and also on Model 626A frequency dial. If wavemeter notch is present on mode

pattern, proceed with paragraph 5-50. If notch is not present, proceed with step m.

m. Loosen setscrews on frequency drive cam. Hold frequency dial in position and adjust the cam (thus moving cam follower, plunger rod, and plunger) until wavemeter notch appears on mode pattern. Tighten setscrews on frequency drive cam.

5- 50. MODE SUPPRESSION AND REFLECTOR TRACKING. Mode suppression in Model 626A consists of reducing effects of the 1/4 wave cavity mode and, in case of vigorous tubes, the 5/4 wave cavity mode. These unwanted modes create most problems around the 12.8 GHz mode switch point and it is here that suppression is conducted.

5-51. Unwanted modes are suppressed before fine reflector tracking adjustments are made, and in rare cases the fine tracking adjustments may interact with the 1/4 wave cavity mode suppression. When this happens the 1/4 wave mode suppressor can be adjusted slightly to restore adequate suppression. Trouble with the 5/4 wave cavity mode is remote; however, proper techniques for suppressing both unwanted modes are described.

a. Connect test setup as shown in Figure 5-11.

b. Set frequency to the high frequency side of mode switching point and look for evidence of the 1/4 wave cavity mode. At this point on the frequency dial the 1/4 wave mode will appear on the high frequency (high

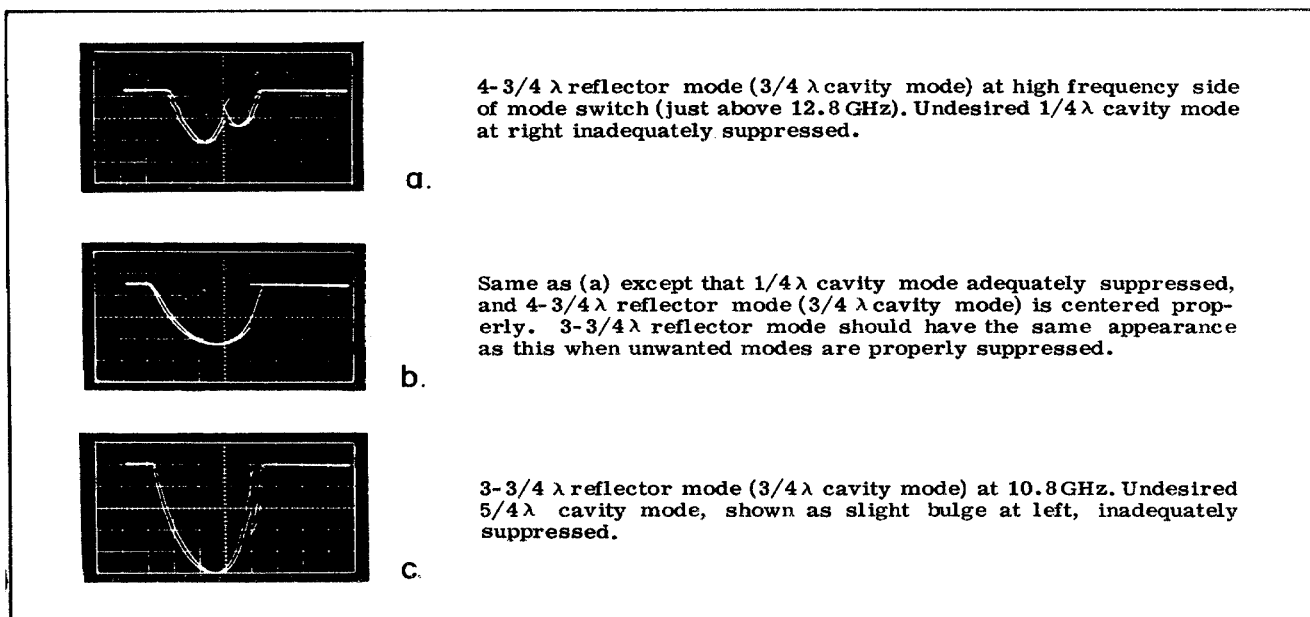

Figure 5-12. Typical Mode Patterns

Model 626A

voltage) side of the desired mode. Under worst conditions two similar modes can be present. Modes can be identified with a wavemeter if doubt exists as to which side of the modes is the high frequency (high voltage) side.

Note

Desired and undesired modes are most easily identified by using a wavemeter. Frequency of the 1/4 wave cavity mode will be from 9.7 to 10.7 GHz while that of the desired mode will correspond closely to that shown on the frequency dial, approximately 12 to 13 GHz. Frequency of the 5/4 wave cavity mode will probably be above 15.5 GHz.

c. Adjust the 1/4 wave mode suppressor matching screw to eliminate interference. Use the special fiber tool supplied with the instrument and refer to Figure 5-13.

WARNING

To reach the 1/4 wave suppressor matching screw the tool must pass between klystron heater and cathode connections. USE CARE due to high negative voltages at these points. The best way to use the special tool is to insert the fiber tube (suppressor locknut wrench) first; then insert the metal suppressor wrench through the fiber tube to adjust the suppressor. Lock down the suppressor matching screw when adjustment is completed. Remove metal wrench, then remove fiber wrench.

d. Tune up the band to 15.5 GHz observing oscilloscope pattern as you go. At higher frequencies the 1/4 wave mode may reappear, but it will be on the low frequency side of the desired mode at these frequencies and will cause no interference. If actual interference

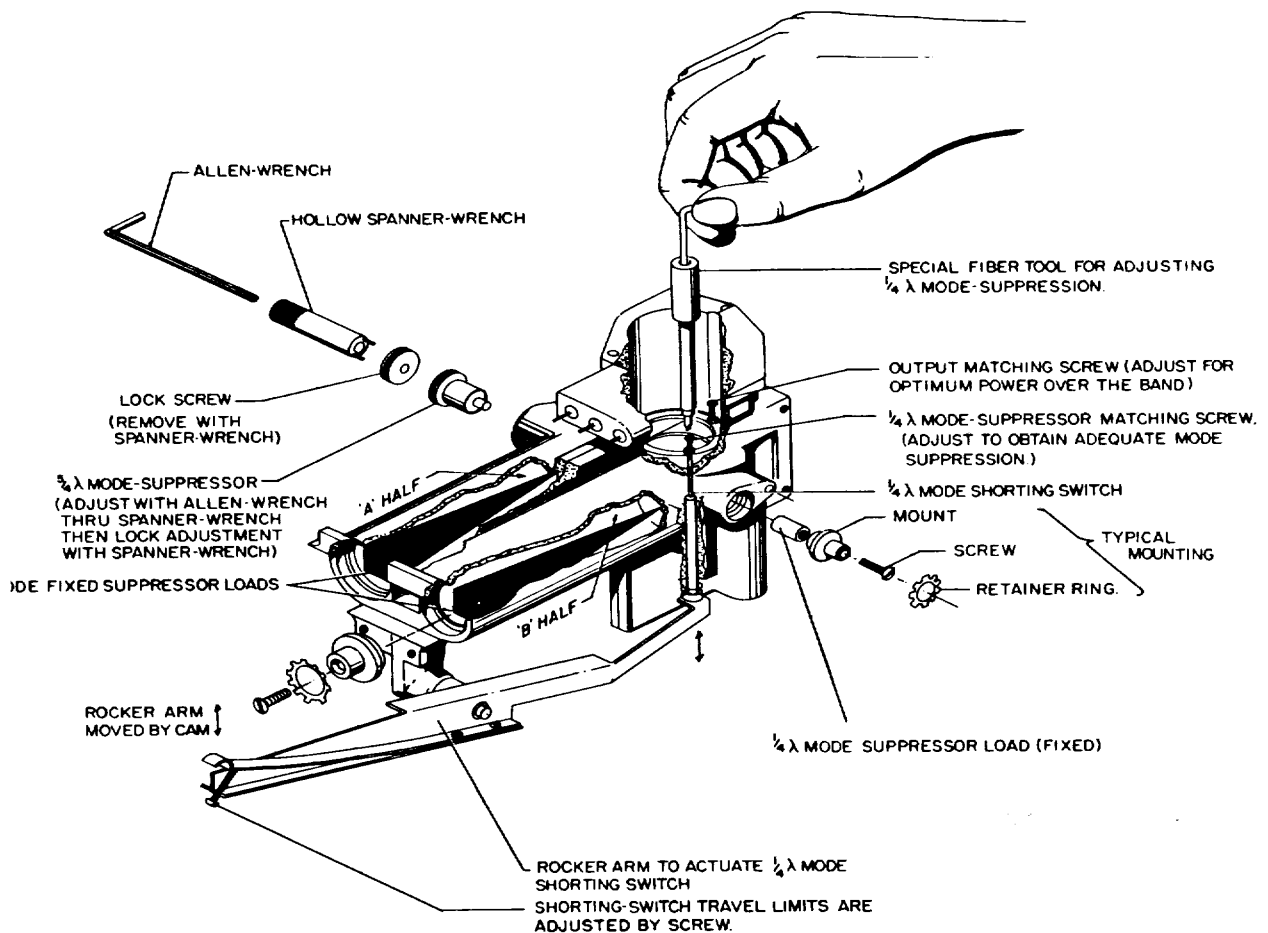

Figure 5-13. Adjustment of Mode Suppressors and Output Matching Screw

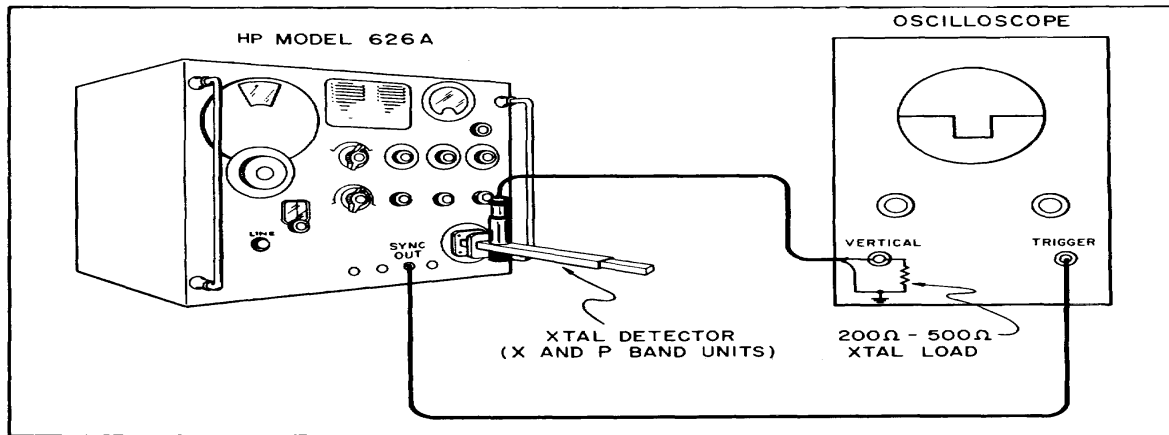

Figure 5-14. Calibration Test Setup

occurs between 12.8 and 15.5 GHz, readjust 1/4 wave mode suppressor matching screw.

e. Tune the frequency dial across the low end of the band from stop to mode switch point. The 5/4 wave mode, if present, will normally appear somewhere below 10. Z GHz. Its presence is revealed as a slight outward bulge on the high frequency side of the desired mode at the base line as shown in Figure 5-12c.

f. To suppress this mode, adjust the 5/4 wave mode suppressor shown in Figure 5-13. Another special tool is provided to assist you in this adjustment; it is the small hollow spanner wrench secured inside the chassis. After unthreading lock screw insert a No. 10 allen wrench through it to adjust suppressor. After achieving the desired suppression, lock suppressor in place.

g. Check across entire frequency band to make sure that all mode suppression is effective.

h. Perform paragraph 5-49, steps f through m, except dial should be set to within 100 MHz of 10 GHz and within 155 MHz of 15.5 GHz. Check points between 10-15.5 GHz. If these points are out of specifications (1%) a compromise of the extremes will correct the dial.

i. After final dial calibration tighten all setscrews.

j. Once undesired modes have been suppressed and final dial calibration performed, the reflector tracking must be fine-adjusted. Center the oscilloscope horizontal trace.

k. Set frequency dial to 10 GHz and adjust R92 so that the vertical centerline of oscilloscope graticule divides the mode pattern about 1/3 of the way from the high

frequency side into the mode. Verify high frequency side, if necessary, with wavemeter.

Note

When MOD SELECTOR is placed in OFF position, voltage applied to reflector should bias the klystron off. If mode pattern is centered on oscilloscope the reflector voltage may not be adequate to bias the klystron off. Pulse and square-wave operation may be deteriorated by failure of klystron to cut off during "off" portion of modulation. If mode pattern is positioned so that the high frequency side is too close to oscilloscope vertical centerline, a weak output is obtained.

m. Set frequency dial to point just before microswitch actuation and adjust mode pattern with R87 as described in step k.

n. Set frequency dial to point just past microswitch actuation and adjust mode pattern with R87 as described in step k.

p. Set frequency dial to 15.5 GHz and adjust mode pattern with R93 as described in step k.

q. Since adjustments are somewhat interacting, tune through frequency range of Model 626A observing tracking behavior. Readjust pots as necessary to produce satisfactory tracking.

5-52. TRACKING CHECK, PULSE AND SQUARE WAVE.

a. Connect test setup as shown in Figure 5-14.

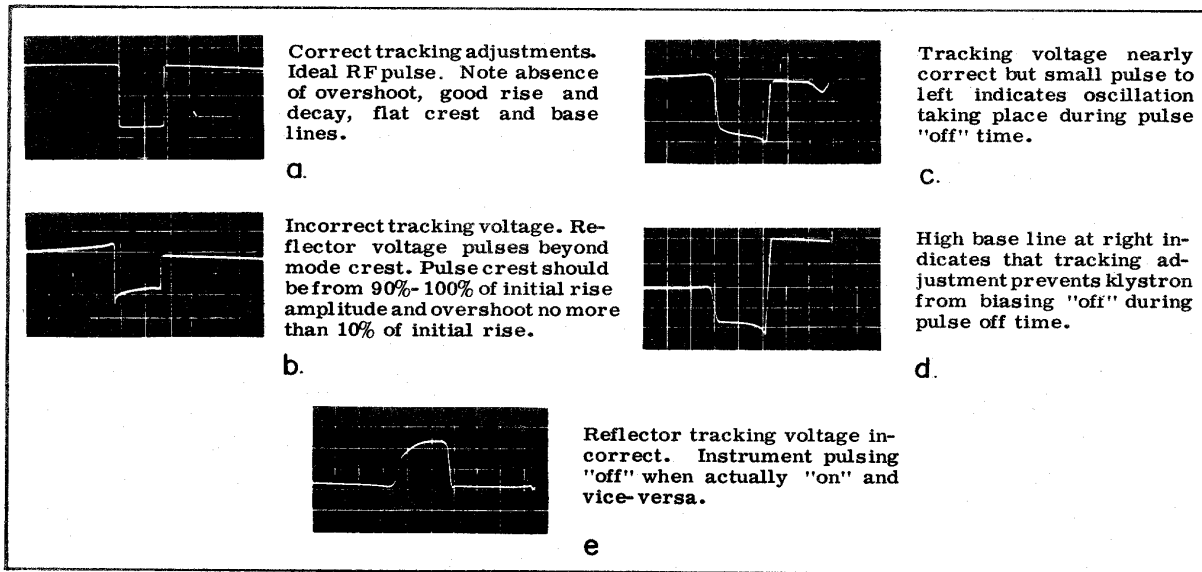

Figure 5-15. Typical Pulse and Square Wave Oscillograms

- b. Set Model 626A controls as follows:
- | | |
|---------------------|-------------|
| SYNC SELECTOR | X10 |
| MOD SELECTOR | INT |
| PULSE RATE | 100 |
| PULSE DELAY | 3 μ sec |
| PULSE WIDTH | 1 μ sec |

c. Adjust oscilloscope for a 1 μ sec/cm sweep.

d. Tune frequency dial on signal generator slowly from 10 to 15.5 GHz while observing pulse shape and pulse base line appearance on oscilloscope. Various pulse waveforms are shown in Figure 5-15. If pulses have sharp overshoot, the reflector tracking potentiometer for that frequency has been adjusted beyond the crest of the mode pattern. A ragged base line indicates that oscillation is taking place when klystron should be cut off. If either of these troubles are present, readjust tracking potentiometer applicable to reflector mode and frequency under examination.

e. Set MOD SELECTOR to OFF and PWR SET to full clockwise position. Tune across the band while observing power-monitor meter for any indication of RF power. Where power is present the reflector tracking voltage for the particular frequency is not properly adjusted and does not bias klystron out of oscillation mode. Adjust appropriate tracking potentiometer to eliminate indication.

5-53. OUTPUT POWER RESPONSE ADJUSTMENT. After satisfactory tracking has been obtained and undesired modes suppressed, the output matching screw must be adjusted as shown in Figure 5-13.

a. Connect test setup as shown in Figure 5-16.

b. Set signal generator frequency dial to 10 GHz and PWR SET for maximum output power as indicated on Model 430C. Record reading obtained.

c. Set signal generator frequency dial to 15.5 GHz and record reading obtained.

d. Adjust output matching screw for a reading approximately midway between readings obtained in steps b and c. This adjustment is interacting so repeat it at 10 and 15.5 GHz until maximum output power is approximately equal at both ends of frequency band.

e. Check across frequency band to see that power monitor meter can be POWER SET.

5-54. CALIBRATION.

5-55. CALIBRATING PULSE RATE DIAL.

5-56. Replacing V9 may change calibration of the pulse rate dial but will not otherwise affect the signal generator performance. If the replacement tube triode sections are too far out of balance, try another tube. Recalibration procedure is as follows:

a. Connect test setup as shown in Figure 5-14. DELAYED SYNC OUT signal may be used instead of the RF pulse.

b. In series with the output of a calibrated audio oscillator, connect a 10K resistor and then connect the oscillator to the vertical input of oscilloscope.

c. Zero-set and power-set the power-monitor meter. Refer to para 3-9b and para 3-9c.

Model 626A

- d. Set Model 626A controls as follows:
- | | |
|---------------------|-----|
| MOD SELECTOR..... | INT |
| SYNC SELECTOR | X10 |
| PULSE RATE | 100 |
- e. Set audio oscillator frequency to 1000 Hz.
 f. Adjust PULSE RATE until sync pulses zero-beat with signal from audio oscillator.
 g. Without changing PULSE RATE control position, slip dial so that 100 is located under index on front panel.
 h. Check PULSE RATE dial calibration at 40 and 400. If dial is in error, slip dial to average error across range.

5-57. CALIBRATING PULSE DELAY DIAL.

- a. Connect test setup as shown in Figure 5-14.
 b. Zero-set and power-set the power-monitor meter. Refer to para 3-9b and para 3-9c.
 c. Set Model 626A controls as follows:
- | | |
|---------------------|-----------|
| MOD SELECTOR..... | NT |
| SYNC SELECTOR | X1 or X10 |
| PULSE DELAY..... | minimum |
- d. Adjust R78 (Figure 5-2) so that delay between SYNC OUT(start of horizontal trace) and leading edge of RF pulse is <3 microseconds on calibrated oscilloscope.
 e. Set PULSE DELAY so that 50 microseconds delay exists between SYNC OUT and leading edge of RF pulse.
 f. Without changing PULSE RATE control position, slip dial so that 50 is located under index on front panel.

- g. Check PULSE DELAY dial calibration at 5 and 200. If necessary repeat steps c through f.
- 5-58. CALIBRATING PULSE WIDTH DIAL.**

- a. Connect test setup as shown in Figure 5-14 except that DELAYED SYNC OUT signal is to be used for triggering oscilloscope.
 b. Zero-set and power-set the power-monitor meter. Refer to para 3-9b and para 3-9c.
 c. Set Model 626A MOD SELECTOR to INT and PULSE WIDTH to minimum.
 d. Adjust R85(Figure 5-2) for a pulse width of just less than 0.5 microseconds as observed on a calibrated oscilloscope.
 e. Locate within frequency band of generator the point of maximum pulse width.
 f. At frequency of maximum pulse width, readjust R85 for a pulse width of just less than 0.5 microseconds.
 g. Set PULSE WIDTH for a 10-microsecond pulse as observed on calibrated oscilloscope.
 h. Without changing PULSE WIDTH control position, slip dial so that 10 is located under index on front panel.

5-59. POWER- MONITOR METER CALIBRATION.

5-60. Replacement of power-set monitoring thermistor (RT123) requires considerable skill and equipment. If facilities are not available consult your Hewlett-Packard field sales engineer or write Customer Service Department at the factory concerning repair.

5-61. If facilities are available, and the replacement is to be made in the field, the entire thermistor mount may be procured as a unit under HP Stock No. 626A-28

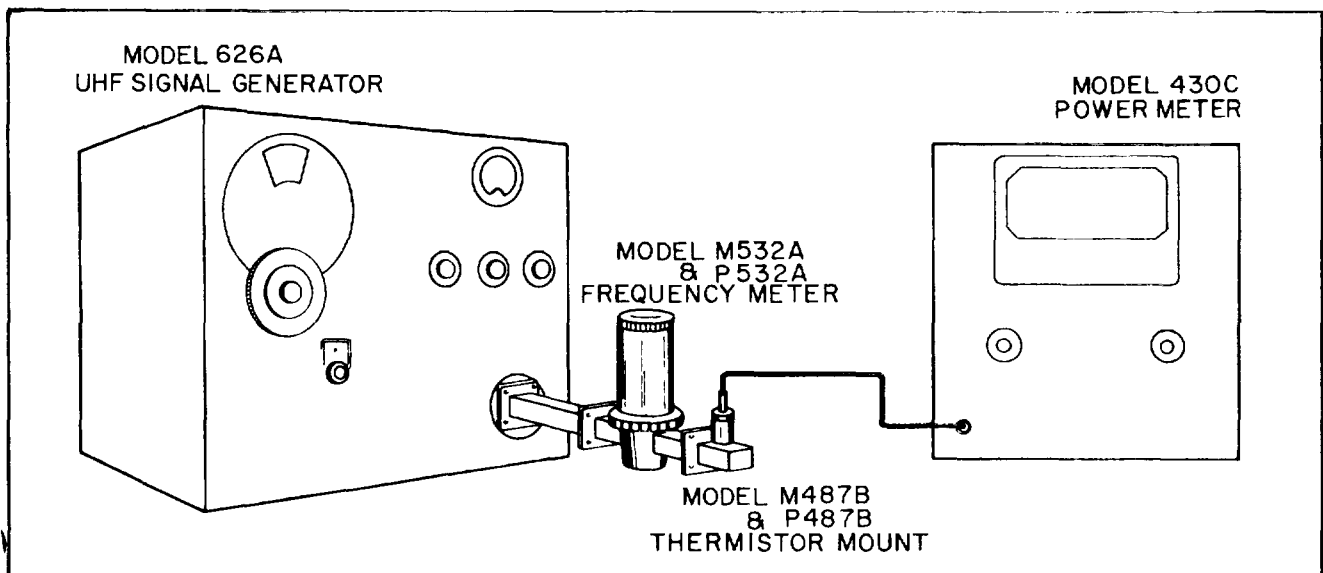

Figure 5-16. Test Setup for Adjusting Output Power

Model 626A

Recalibration procedure for the power- monitor meter is as follows:

- a. Connect test setup as shown in Figure 5-16.
- b. Set Model 626A MOD SELECTOR to CW and frequency dial to center of band (12.75GHz).
- c. Set OUTPUT ATTEN to -2 dBm and adjust PWR SET for a -2 dBm reading on Model 430C.
- d. Adjust R108 (Figure 5-7) so that power-monitor meter indicates 0 dBm (red line at center of scale).

Note

To increase accuracy of power output calibration at a particular frequency follow the above procedure at that frequency.

5-62. PERFORMANCE CHECKS.

5-63. Performance checks are included to verify proper operation of the Model 626A. They may be used by incoming quality control for the electrical inspection.

5-64. FREQUENCY CALIBRATION CHECK.

- a. Connect test setup as shown in Figure 5-16 using M- band equipment.
- b. Set signal generator frequency dial to 10 GHz.
- c. Zero-set and power-set the power-monitor meter. Refer to para 3-9b and para 3-9c.
- d. Set MOD SELECTOR to CW and OUTPUTATTEN to 0 dBm.
- e. Adjust power meter to read 0 dBm(1 mW).
- f. Adjust frequency meter to locate a dip in power around the frequency output of signal generator. Frequency meter should read 10 GHz \pm 100 MHz.

g. Set signal generator frequency dial to 12.5 GHz, and repeat steps c through f. Frequency meter should read 12.5 GHz \pm 125 MHz.

h. Remove M-band equipment from test setup, and replace with P-band equipment using the Model MP292B Adapter. Adapter is to be connected between frequency meter and RF OUTPUT of signal generator.

i. Set signal generator frequency dial to 15.5 GHz, and repeat steps c through f. Frequency meter should read 15.5 GHz \pm 155 MHz.

5-65. OUTPUT POWER CHECK.

- a. Connect test setup as shown in Figure 5-16 using P-band equipment and the Model MP292B Adapter.
- b. Using a calibrated frequency meter, set signal generator output for 15.5 GHz.
- c. Zero-set and power-set the power-monitor meter. Refer to paragraphs 3-9b and 3-9c.
- d. Set MOD SELECTOR to OFF and OUTPUT ATTEN to -1 dBm.
- e. Zero-set a power meter such as a Model 430C as per its instruction manual, and set RANGE switch to 0 dBm.
- f. Set signal generator MOD SELECTOR to CW.
- g. With Model 430C properly zero-set, the meter should read -1 dBm \pm 1 dB.
- h. Repeat steps b through g except set signal generator output for 12.5 GHz.
- i. Remove P-band equipment and adapter from test setup and replace with M-band equipment.
- j. Repeat steps b through g except set signal generator output for 10 GHz.

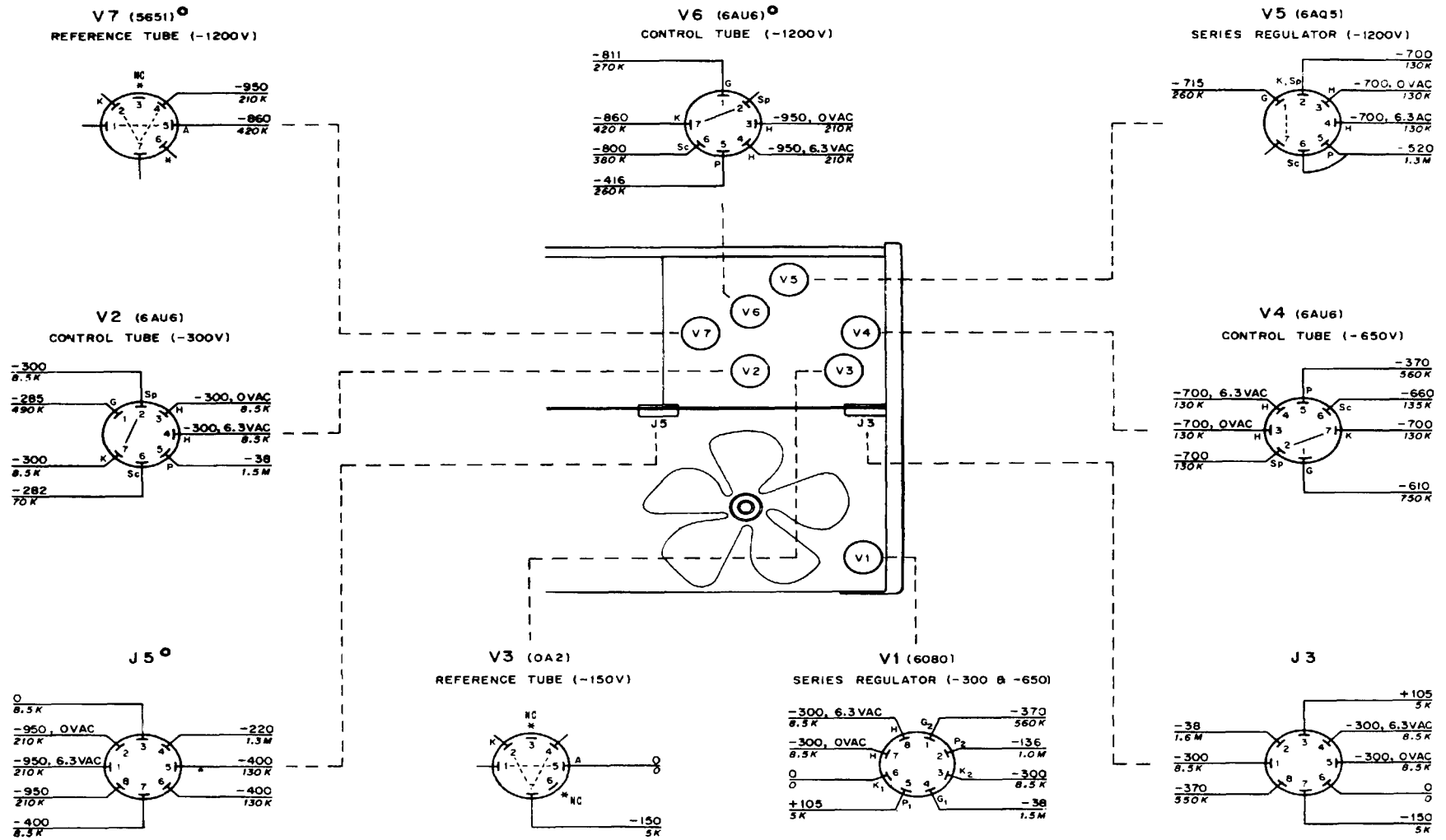

Model 626A

Figure 5-17. Power Supply, Voltage and Resistance Diagram

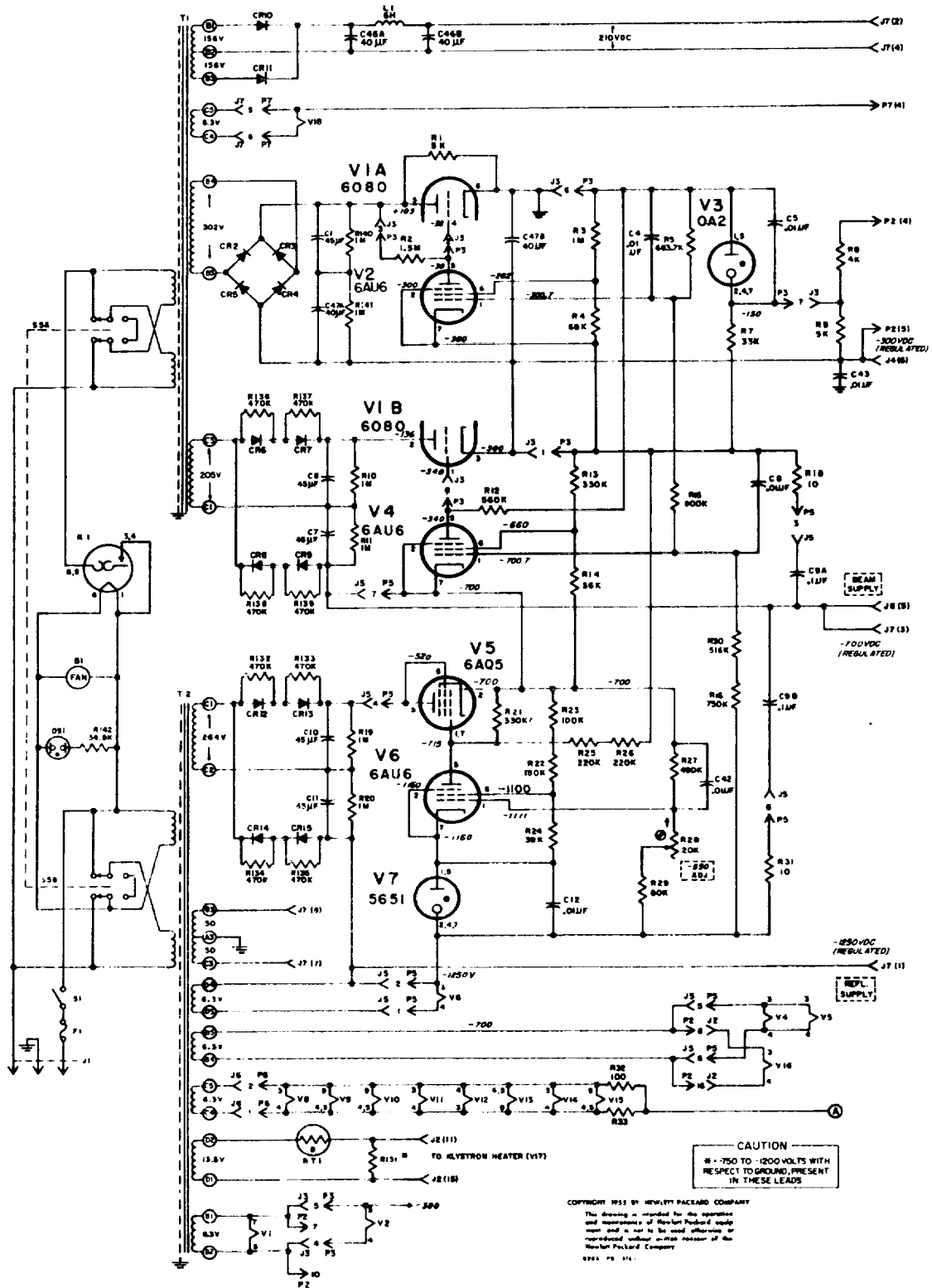

Figure 5-18. Power Supply

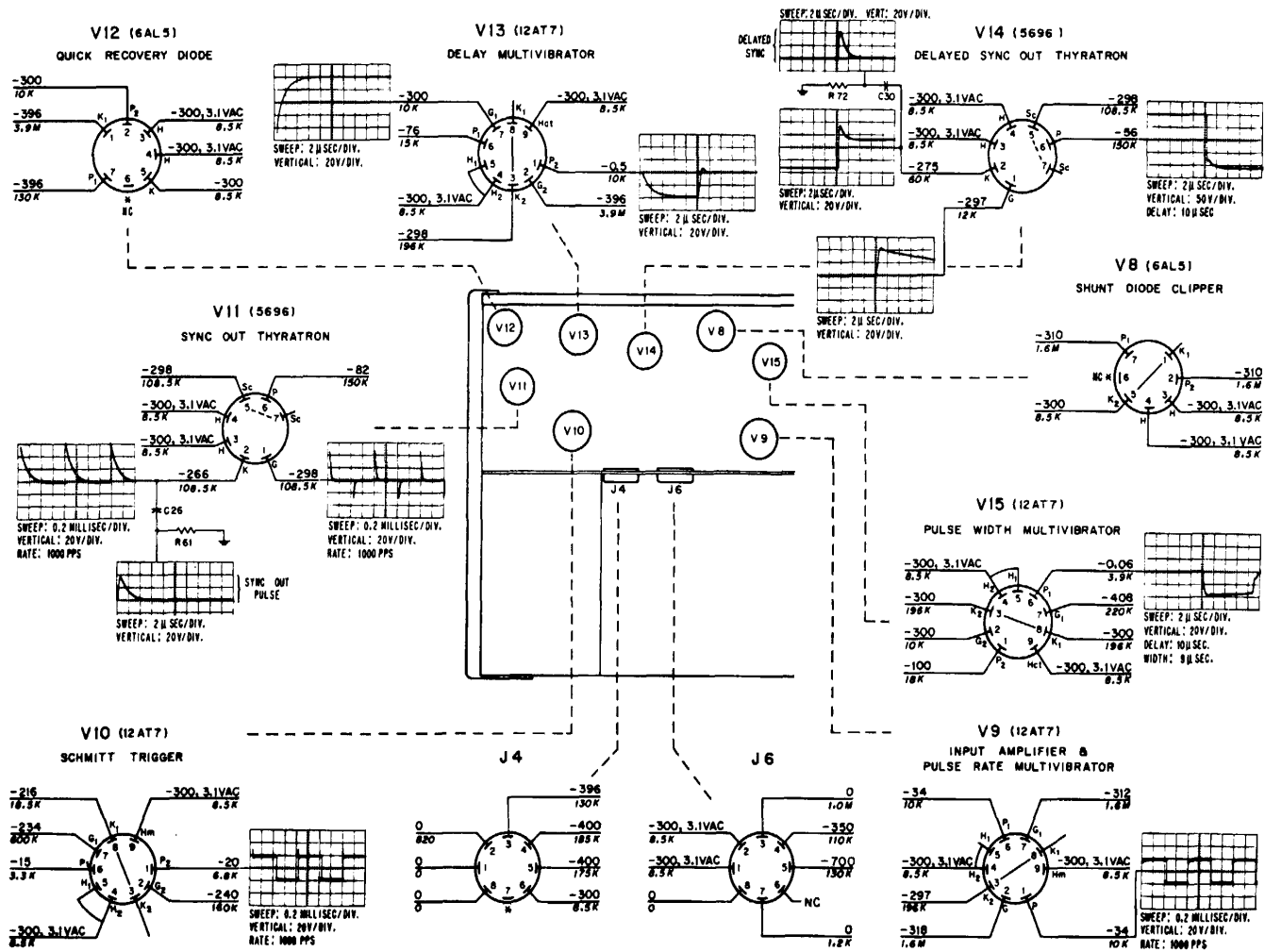

Figure 5-19. Pulse Section, Voltage and Resistance Diagram

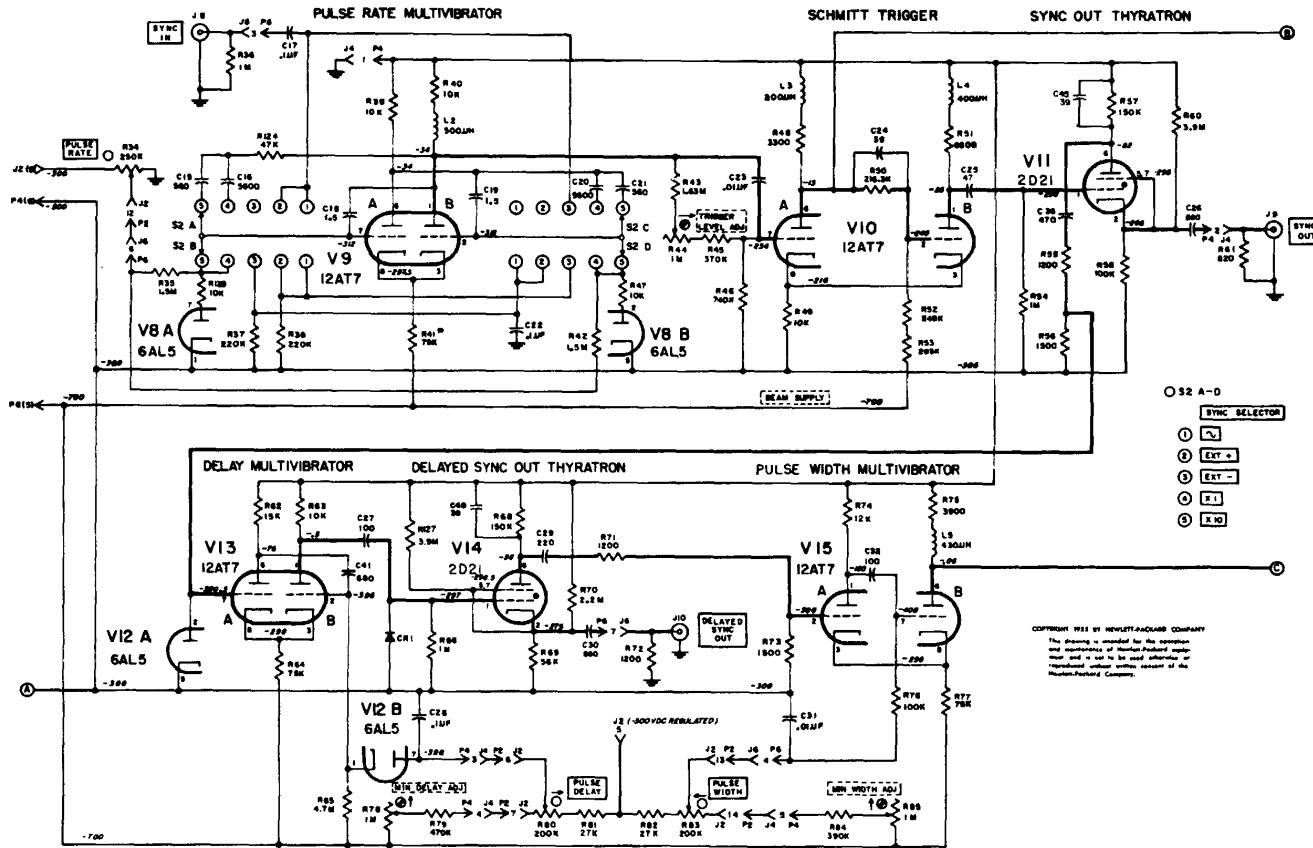

Figure 5-20. Pulse Generator

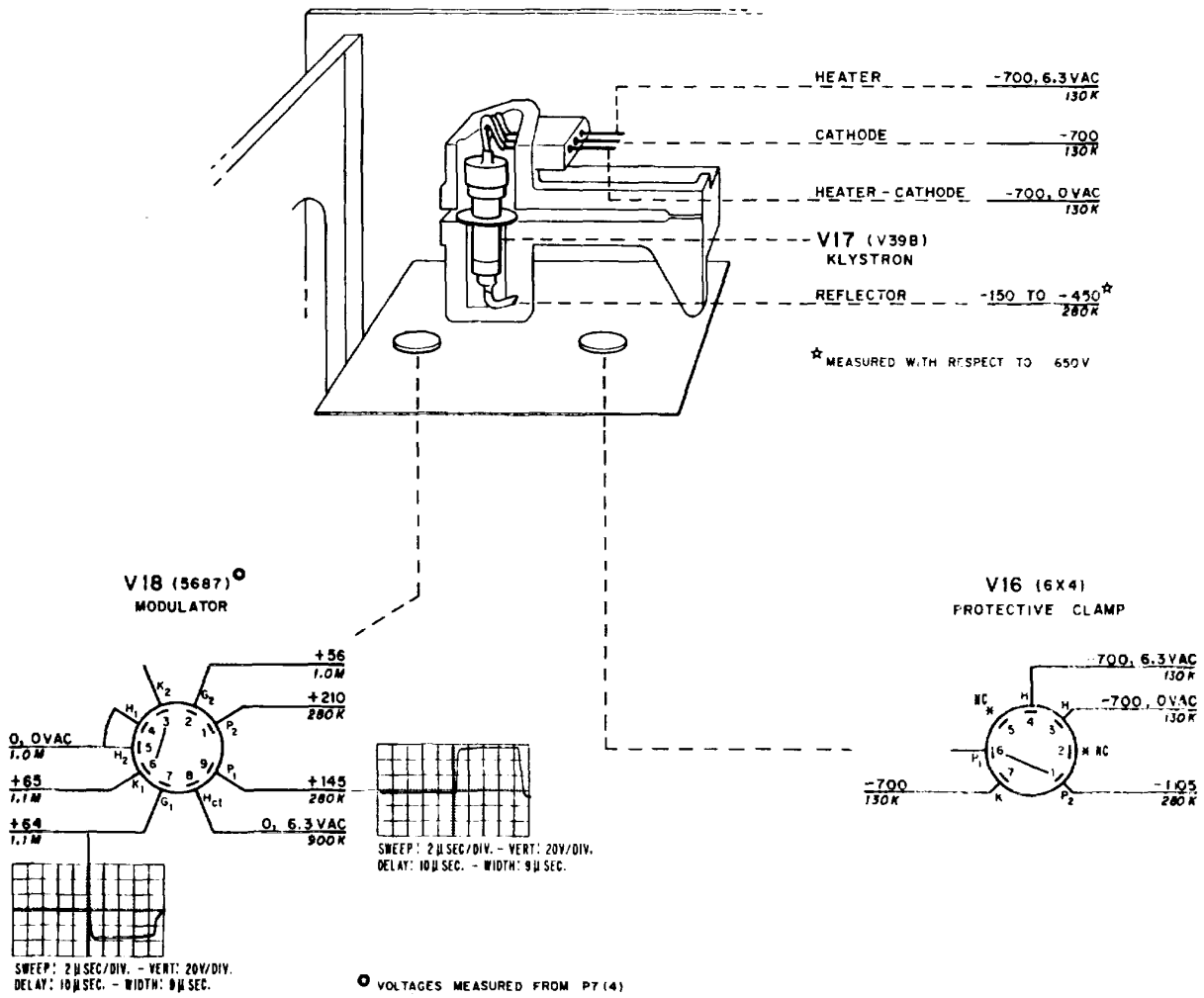

Figure 5-21. Modulator and RF Generator Sections, Voltage and Resistance Diagram

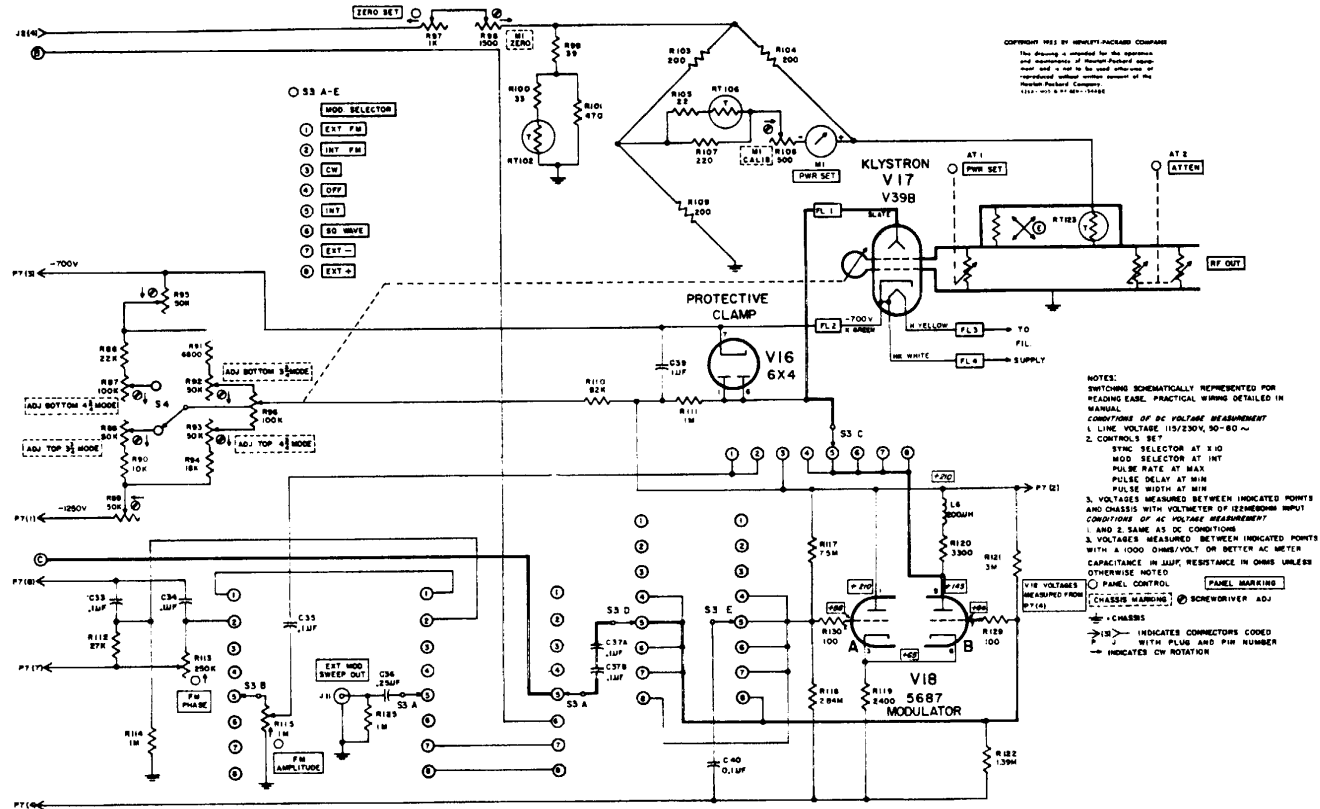

Figure 5-22. Modulator and RF Generator

5-2715-28

**SECTION VI
REPLACEABLE PARTS**

6-1. INTRODUCTION.

6-2. This section contains information for ordering replacement parts. Table 6-1 lists parts in alphanumeric order of their reference designators and indicates the description and stock number of each part, together with any applicable notes. Table 6-2 lists parts in alpha- numerical order of their stock numbers and provides the following information on each part:

- a. Description of the part (see list of abbreviations below).
- b. Typical manufacturer of the part in a five-digit code; see list of manufacturers in appendix.
- c. Manufacturer's stock number.
- d. Total quantity used in the instrument (TQ col.)
- e. Recommended spare part quantity for complete maintenance during one year of isolated service (RS column).

6-3. Miscellaneous parts not indexed in table 6-1 are listed at the end of Table 6-2.

6-4. ORDERING INFORMATION.

6-5. To order a replacement part, address order or inquiry either to your authorized Hewlett- Packard sales representative or to

CUSTOMER SERVICE
Hewlett- Packard Company
333 Logue Avenue
Mountain View, California

or, in Western Europe, to
Hewlett- Packard S. A.
1217 Meyrin
Geneva, Switzerland

6-6. Specify the following information for each part:

- a. Model and complete serial number of instrument.
- b. Hewlett-Packard stock number.
- c. Circuit reference designator.
- d. Description.

6-7. To order a part not listed in Table 6-1 and Table 6-2, give a complete description of the part and include its function and location.

REFERENCE DESIGNATORS

A = assembly	F = fuse	P = plug	V = vacuum tube, neon bulb, photocell, etc.
B = motor	FL = filter	Q = transistor	W = cable
C = capacitor	J = jack	R = resistor	X = socket
CR = diode	K = relay	RT = thermistor	XF = fuseholder
DL = delay line	L = inductor	RT = thermistor	XDS = lampholder
DS = device signaling (lamp)	M = meter	S = switch	Z = network
E = misc electronic part	MP = mechanical part	T = transformer	

ABBREVIATIONS

a = amperes	elect = electrolytic	mtg = mounting	rot = rotary
bp = bandpass	encap = encapsulated	my = mylar	rms = root-mean-square
bwo = backward wave oscillator	f = farads	NC = normally closed	rmo = rack mount only
c = carbon	fxd = fixed	Ne = neon	s-b = slow-blow
cer = ceramic	Ge = germanium	NO = normally open	Se = selenium
cmo = cabinet mount only	grd = ground(ed)	NPO = negative positive zero (zero temperature coefficient)	sect = section(s)
coef = coefficient	h = henries	nsr = not separately replaceable	Si = silicon
com = common	Hg = mercury	obd = order by description	sil = silver
comp = composition	imp = impregnated	p = peak	sl = slide
conn = connection	incd = incandescent	pc = printed circuit board	td = time delay
crt = cathode-ray tube	ins = insulation(ed)	pf = picofarads = 10 ⁻¹² farads	TiO ₂ = titanium dioxide
dep = deposited	K = kilo = 1000	pp = peak-to-peak	tog = toggle
EIA = Tubes or transistors meeting Electronic Industries' Association standards will normally result in instrument operating within specifications; tubes and transistors selected for best performance will be supplied if ordered by HP stock numbers.	lin = linear taper	piv = peak inverse voltage	tol = tolerance
	log = logarithmic taper	pos = position(s)	trim = trimmer
	m = milli = 10 ⁻³	pot = potentiometer	twt = traveling wave tube
	M = megohms	rect = rectifier	var = variable
	ma = milliamperes		w/ = with
	μ = micro - 10 ⁻⁶		W = watts
	minat = miniature		ww = wirewound
	mfgl = metal film on glass		w/o = without
	Mfr = manufacturer		* = optimum value selected at factory, average value shown(part may be omitted)

Table 6-1. Reference Designation Index

Circuit Reference	HP Stock No.	Description #	Note
AT1		PWR SET attenuator assembly (not field replaceable)	
AT2		RF attenuator assembly (not field replaceable)	
B1	3140-0052 3160-0012	Motor, fan Blade, fan	
C1	0180-0019	C: fxd, elect, 451 μ f -10% +50%, 450 vdcw	
C2, 3		Not Assigned	
C4, 5	0150-0012	C: fxd, cer, 0.01 μ f \pm 20%, 1000 vdcw	
C6, 7	0180-0019	C: fxd, elect, 45 μ f -10%+50%, 450 vdcw	
C8	0150-0012	C: fxd, cer, 0.01 μ f +20%, 1000 vdcw	
C9A,B	0160-0089	C: fxd, paper, 2 sect., 0.1 μ f/sect, -10% +20%, 1000 vdcw	
C10, 11	0180-0019	C: fxd, elect, 45 μ f -10% +50%, 450 vdcw	
C12	0150-0012	C: fxd, cer, 0.01 μ f \pm 20%, 1000 vdcw	
C13, 14		Not Assigned	
C15	0140-0028	C: fxd, mica, 560pf \pm 10%, 500 vdcw	
C16	0140-0071	C: fxd, sil mica, 5600pf \pm 10%, 500 vdcw	
C17	0160-0050	C: fxd, paper, 0.1 μ f \pm 10%, 400 vdcw	
C18, 19	0150-0011	C: fxd, TiO ₂ , 1.5pf \pm 20%, 500 vdcw	
C20	0140-0071	C: fxd, sil mica, 5600pf \pm 10%, 500 vdcw	
C21	0140-0028	C: fxd, mica, 560pf \pm 10%, 500 vdcw	
C22	0160-0050	C: fxd, paper, 0.1 μ f +10%, 400 vdcw	
C23	0150-0012	C: fxd, cer, 0.0 μ f \pm 20%, 1000 vdcw	
C24	0140-0035	C: fxd, mica, 39pf \pm 5%, 500 vdcw	
C25	0140-0032	C: fxd, mica, 47pf \pm 10%, 500 vdcw	
C26	0140-0044	C: fxd, mica, 560pf +10%	
C27	0140-0041	C: fxd, mica, 100pf \pm 10%, 500 vdcw	
C28	0160-0050	C: fxd, paper, 0.1 μ f \pm 10%, 400 vdcw	
C29	0140-0031	C: fxd, mica, 220pf \pm 10%, 500 vdcw	
C30	0140-0044	C: fd, mica, 560pf \pm 10%	
C31	0150-0012	C: fxd, cer, 0.01pf \pm 20%, 1000 vdcw	
C32	0140-0041	C: fxd, mica, 100pf \pm 10%, 500 vdcw	
C33, 34,	0160-0050	C: fxd, paper, 0.1 μ f \pm 10%, 400 vdcw	
C35	0160-3192	C: fxd, paper, 0.1pf \pm 10%, 1200 vdcw	
C36	0160-0088	C: fxd, paper, 0.25 μ f \pm 10%, 1500, vdcw	

See introduction to this section

Table 6-1. Reference Designation Index (Cont'd)

Circuit Reference	HP Stock No.	Description #	Note
C37A, B	0160-0089	C: fxd, paper, 2 sect., 0.1µf/sect, -10%±20%, 1000 vdcw	
C38	0140-0027	C: fxd, mica, 470pf ±10%, 500 vdcw	
C39	0160-0079	C: fxd, paper, 1µf ±10%, 600 vdcw	
C40	0170-0055	C: fxd, cer, 0.1µf ±20%, 1000 vdcw	
C41	0140-0007	C: fxd, mica, 680pf ±10%, 500 vdcw	
C42, 43	0150-0012	C: fxd, cer, 0.01µf ±20%, 1000 vdcw	
C44		Not Assigned	
C45	0140-0021	C: fxd, mica, 39pf ±10%, 500 vdcw	
C46A/B, 47A/B	0180-0125	C: fxd, elect, 4 sect., 205µf/sect, 450 vdcw	
C48	0140-0021	C: fxd, mica, 39pf ±10%, 500 vdcw	
CR1	1910-0016	Diode, Ge	
CR2 thru CR15	1901-0029	Diode, Si	
DS1	2140-0244	Lamp: Glow	
F1	2110-0055	Fuse, cartridge: 4amp,(For 115 V operation)	
	2110-0002	Fuse, cartridge: 2 amp, For 230 V operation)	
J1	1251-2357	Connector: AC Receptacle 3 pin male	
J2	1251-0007	Connector, female: 16 contact	
J3 thru J6	1200-0005	Socket, tube: octal	
J7	1250-0035	Socket, tube	
J8 thru J10	1250-0075	Connector: BNC panel jack	
J11	1250-0074	Connector, female: BNC	
K1	0490-0009	Relay: time delay, SPST	
L1	9110-0011	Reactor, filter: 6 h	
L2	9140-0022	Inductor, RF: 500 µh	
L3	9140-0019	Inductor, RF: 200 µh	
L4	9140-0020	Inductor, RF: 400 µh	
L5	9140-0021	Inductor, RF: 430 µh	
L6	9140-0019	Inductor, RF: 200 µh	
M1	1120-0037	Meter, PWR SET	

See introduction to this section

Table 6-1. Reference Designation Index (Cont'd)

Circuit Reference	HP Stock No.	Description #	Note
P1	8120-1348	Power cable: Detachable	
P2	1251-0006	Connector, male: 16 contact	
P3 thru P6	1251-0026	Connector, male: octal	
P7	1251-0052	Connector, male: 11 pin	
R1	0816-0006	R: fxd, ww, 5K ohms $\pm 10\%$, 10 W	
R2	0687-1551	R: fxd, comp, 1.5M $\pm 10\%$, 1/2 W	
R3	0687-1051	R: fxd, comp, 1M $\pm 10\%$, 1/2 W	
R4	0687-6831	R: fxd, comp, 68K ohms $\pm 10\%$, 1/2 W	
R5	0730-0096	R: fxd, dep c, 683.7K ohms $\pm 1\%$, 1 W	
R6		Not Assigned	
R7	0693-3331	R: fxd, comp, 33K ohms $\pm 10\%$, 2 W	
R8	0815-0003	R: fxd, ww, 4K ohms $\pm 5\%$, 10 W	
R9	0816-0006	R: fxd, ww, 5K ohms $\pm 10\%$, 10 W	
R10, 11	0690-1051	R: fxd, comp, 1M $\pm 10\%$, 1 W	
R12	0690-5641	R: fxd, comp, 560K ohms $\pm 10\%$, 1 W	
R13	0693-3341	R: fxd, comp, 330K ohms $\pm 10\%$, 2 W	
R14	0686-3635	R: fxd, comp, 36K ohms $\pm 5\%$, 1/2 W	
R15	0730-0103	R: fxd, dep c, 900K ohms $\pm 1\%$, 1 W	
R16	0727-0253	R: fxd, dep c, 750K ohms $\pm 1\%$, 1/2 W	
R17		Not Assigned	
R18	0690-1001	R: fxd, comp, 10 ohms $\pm 10\%$, 1 W	
R19, 20	0690-1051	R: fxd, comp, 1M $\pm 10\%$, 1 W	
R21	0690-3341	R: fxd, comp, 330K ohms $\pm 10\%$, 1 W	
R22	0693-1541	R: fxd, comp, 150K ohms $\pm 10\%$, 2 W	
R23	0690-1041	R: fxd, comp, 100K ohms $\pm 10\%$, 1 W	
R24	0687-3931	R: fxd, comp, 39K ohms $\pm 10\%$, 1/2 W	
R25, 26	0690-2241	R: fxd, comp, 220K ohms $\pm 10\%$, 1 W	
R27	0730-0092	R: Xfd, dep c, 490K ohms $\pm 1\%$, 1 W	
R28	2100-0098	R: var, comp, lin, 20K ohms $\pm 20\%$	
R29	0730-0062	R: fxd, dep c, 80K ohms $\pm 1\%$, 1 W	
R30	0730-0093	R: fxd, dep c, 516K ohms $\pm 1\%$, 1W	
R31	0690-1001	R: fxd, comp, 10 ohms $\pm 10\%$, 1 W	
R32, 33	0687-1011	R: fxd, comp, 100 ohms $\pm 10\%$, 1/2 W	
R34	2100-0034	R: var, comp, lin; 250K ohms $\pm 10\%$	

See introduction to this section

Table 6-1. Reference Designation Index (Cont'd)

Circuit Reference	HP Stock No.	Description #	Note
R35	0686-1555	R: fxd, comp, 1. 5M ±5%, 1/2 W	
R36	0687-1051	R: fxd, comp, 1M ±10%, 1/2 W	
R37, 38	0687-2241	R: fxd, comp, 220K ohms ±10%, 1/2 W	
R39, 40	0690-1031	R: fxd, comp, 10K ohms ±10%, 1 W	
R41*	0777-0002	R: fxd, mfgl, 75K ohms ±5%, 7 W (Factory Selected Part, Typical Value Given)	
R42	0686-1555	R: fxd, comp, 1.5M ±5%, 1/2 W	
R43	0730-0110	R: fxd, dep c, 1. 63M ±1%, 1W	
R44	2100-0096	R: var, comp, lin, 1M ±30%, 1/4 W	
R45	0730-0087	R: fxd, dep c, 370K ohms ±1%, 1 W	
R46	0727-0252	R: fxd, dep c, 740K ohms ±1%, 1/2 W	
R47	0687-1031	R: fxd, comp, 10K ohms ±10%, 1 W	
R48	0687-3321	R: fxd, comp, 3.3K ohms ±10%, 1/2 W	
R49	0770-0004	R: fxd, mfgl, 10K ohms ±5%, 4 W	
R50	0727-0223	R: fxd, dep c, 216.3K ohms ±19%b, 1/2 W	
R51	0693-6821	R: fxd, comp, 6. 8K ohms ±10%, 2 W	
R52	0730-0080	R: fxd, dep c, 245K ohms, ± 19, 1W	
R53	0730-0082	R: fxd, dep c, 265K ohms ± 1%, 1W	
R54	0687-4731	R: fxd, comp, 47K ohms ±10%, 1/2 W	
R55	0690-1221	R: fxd, comp, 1. 2K ohms ±10%, 1 W	
R56	0687-1521	R: fxd, comp, 1.5K ohms ±10%, 1/2 W	
R57	0687-1541	R: fKd, comp, 150K ohms ±10%, 1/2 W	
R58	0687-1041	R: fxd, comp, 100K ohms ±10%, 1/2 W	
R60	0687-3951	R: fxd, comp, 3.9M ±10%, 1/2 W	
R61	0687-8211	R: fxd, comp, 820 ohms ±10%, 1/2 W	
R62	0693-1531	R: fxd, comp, 15K ohms ±10%, 2 W	
R63	0690-1031	R: fxd, comp, 10K ohms ±10%, 1 W	
R64	0777-0002	R: fxd, mfgl, 75K ohms ±5%, 7 W	
R65	0690-4751	R: fxd, comp, 4.7M ±10%, 1 W	
R66	0687-1041	R: fxd, comp, 100K ohms ±10%, 1/2 W	
R68	0687-1541	R: fxd, comp, 150K ohms ±10%, 1/2 W	
R69	0687-5631	R: fxd, comp, 56K ohms ±10%, 1/2 W	
R70	0687-2251	R: fxd, comp, 2. 2M ±10%, 1/2 W	
R71, 72	0687-1221	R: fxd, comp, 1.2K ohms ±10%, 1/2 W	
R73	0687-1521	R: fxd, comp, 1.5K ohms ±10%, 1/2 W	
R74	0693-1231	R: fxd, comp, 12K ohms ±10%, 2 W	
R75	0687-3921	R: fxd, comp, 3.9K ohms ±10%, 1/2 W	

See introduction to this section

Table 6-1. Reference Designation Index (Cont'd)

Circuit Reference	HP Stock No.	Description #	Note
R76	0687-1041	R: fxd, comp, 100K ohms $\pm 10\%$, 1/2 W	
R77	0777-0002	R: fd, mfgl, 75K ohms $\pm 5\%$, 7 W	
R78	2100-0096	R: var, comp, lin, 1M $\pm 30\%$, 1/4 W	
R79	0687-4741	R: fxd, comp, 470K ohms $\pm 10\%$, 1/2 W	
R80	2100-0014	R: var, comp, 220K ohms $\pm 20\%$	
R81, 82	0687-2731	R: fxd, comp, 27K ohms $\pm 10\%$, 1/2 W	
R83	2100-0014	R: var. comp, 220K ohms $\pm 20\%$	
R84	0687-3941	R: ixd, comp, 390Kohms $\pm 10\%$, 1/2 W	
R85	2100-0096	R: var, comp, lin, 1M $\pm 30\%$, 1/4 W	
R86	0690-2231	R: fxd, comp, 22K ohms $\pm 10\%$, 1 W	
R87	2100-0045	R: var, comp, 100K ohms $\pm 10\%$	
R88, 89	2100-0028	R: var, comp, 50K ohms $\pm 10\%$	
R90	0690-1031	R: fxd, comp, 10K ohms $\pm 10\%$, 1 W	
R91	06904821	R: fxd, comp, 6800 ohms, $\pm 10\%$, 1W	
R92, 93	2100-0028	R: var, comp, 50K ohms $\pm 10\%$	
R94	0693-1831	R: fxd, comp, 18K ohms $\pm 10\%$, 2 W	
R95	2100-0028	R: var, comp, 50K ohms $\pm 10\%$	
R96	2100-0120	R: var, ww, 100K ohms tapped at 50K ohms, $\pm 5\%$, 8 W	
R97	2100-0036	R: var, comp, lin, 1K ohms	
R98	2100-0025	R: var, comp, lin, 1.5K ohms $\pm 10\%$	
R99	0687-3901	R: fxd, comp, 39 ohms $\pm 10\%$, 1/2 W	
R100	0687-3301	R: fxd, comp, 33 ohms $\pm 10\%$, 1/2 W	
R101	0687-4711	R: fxd, comp, 470 ohms $\pm 10\%$, 1/2 W	
R102		Not Assigned	
R103, 104	628A-67A	R: fxd, ww, 200 ohms	
R105	0687-2201	R: fxd, comp, 22 ohms $\pm 10\%$, 1/2 W	
R106		Not Assigned	
R107	0687-2211	R: fxd, comp, 220 ohms $\pm 10\%$, 1/2 W	
R108	2100-0068	R: var, comp, lin, 500 ohms	
R109	628A-67A	R: fxd, ww, 200 ohms	
R110	0687-8231	R: fxd, comp, 82K ohms $\pm 10\%$, 1/2 w	
R111	0687-1051	R: fxd, comp, 1M $\pm 10\%$, 1/2 W	
R112	0687-2731	R: fxd, comp, 27K ohms $\pm 10\%$, 1/2 W	
R113	2100-0034	R: var, comp, lin, 250K ohms $\pm 10\%$	

See introduction to this section

Table 6-1. Reference Designation Index (Cont'd)

Circuit Reference	HP Stock No.	Description #	Note
R114	0687-1051	R: fxd, comp, 1M ±10%, 1/2 W	
R115	2100-0047	R: var, 1M ±20%, 2 W	
R116		Not Assigned	
R117	0730-0131	R: fxd, dep c, 7. 5M ±10%, 1 W	
R118	0727-0291	R: fxd, dep c, 2.84M ±10%, 1/2 W	
R119	0770-0002	R: fxd, mfgl, 2.4 ohms ±5%, 4 W	
R120	0770-0003	R: fxd, mfgl, 3.3 ohms ±5%, 4 W	
R121	0727-0292	R: fxd, dep c, 3M ±1%, 1/2 W	
R122	0727-0281	R: fxd, dep c, 1.39M ±1%, 1/2 W	
R123		Not Assigned	
R124	0687-4731	R: fxd, comp, 47K ohms ±109%, 1/2 W	
R125	0687-1051	R: fxd, comp, 1M ±10%, 1/2 W	
R126, 127	0687-3951	R: fxd, comp, 3.9M ±10% 1/2 W	
R128	0687-1031	R: fxd, comp, 10K ohms ±10%, 1/2 W	
R129, 130	0687-1011	R: fxd, comp, 100 ohms ±10%, 1/2 W	
R131*	0693-1801	R: fxd, comp, 18 ohms ±10%, 2 W (2 per)	
R132 thru 139	0690-4741	R: fxd, comp, 470K ohms ±10%, 1 W	
R140, 141	0690-1051	R: fxd, comp, 1M ±10%, 1 W	
R142	0757-0123	R: fxd, met nm, 34.8K ohm, 1%, 1/8 W	
RT1	0852-0007	Tube, ballast, No. 13-4	
RT2 thru 101		Not Assigned	
RT102	0839-0003	Thermistor, disc	
RT103 thru 105		Not Assigned	
RT106	0839-0003	Thermistor, disc	
RT107 thru 122		Not Assigned	
RT123	0839-0022	Thermistor,	
S1	3101-1248	Switch, Push button	
S2A, B, C, D	3100-0121	Switch, rot: (SYNC SEL.) 2 sect	
S3	3100-0111	Switch, rot: (MOD, SEL.) 3 sect	
S4	3102-0001	Switch, micro: SPST, 10 amp	
	3102-0002	S4 Actuator	
S5	3101-1272	Switch: 4PDT slide	
T1	9100-0114	Transformer, power	
T2	9100-0115	Transformer, power	

See introduction to this section

Table 6-1. Reference Designation Index (Cont'd)

Circuit Reference	HP Stock No.	Description #	Note
V1	1932-0010	Tube, electron: 6080	
V2	1923-0021	Tube, electron: 6AU6	
V3	1940-0004	Tube, electron: OA2	
V4	1923-0021	Tube, electron: 6AU6	
V5	1923-0018	Tube, electron: 6AQ5	
V6	1923-0021	Tube, electron: 6AU6	
V7	1940-0001	Tube, electron: 5651	
V8	1930-0013	Tube, electron: 6AL5	
V9, 10	1032-0027	Tube, electron: 12AT7	
V11	1941-0006	Tube, electron: 2D21	
V12	1930-0013	Tube, electron: GAL5	
V13	1932-0027	Tube, electron: 12AT7	
V14	1941-0005	Tube, electron: 2D21	
V15	1932-0027	Tube, electron: 12AT7	
V16	1930-0016	Tube, electron: 6X4	
V17		Tube, klystron: (nsr) Part of klystron cavity assembly.)	
V18	1932-0002	Tube, electron: 5687	

See introduction to this section

Model 626A

Table 6-2. Replaceable Parts

HP Stock No.	Description #	Mfr.	Mfr. Part No .	TQ	RS		
628A-67A	R: fxd, ww, 200 ohms	28480	628A-67A	3	1		
0140-0003	C: fxd, mica, 1000pf ±10%, 500 vdcw	76433	RCM30B1OZK	2	1		
0140-0007	C: fxd, mica, 680pf ±10%, 500 vdcw	00853	K1368B10	1	1		
0140-0021	C: fxd, mica, 39pf ±10%, 500 vdcw	00853	DR1439B10	1	1		
0140-0027	C: fxd, mica, 470pf ±10%, 500 vdcw	11711	CM20B471KN3	1	1		
0140-0028	C: fxd, mica, 560pf ±10%, 500 vdcw	72136	CM308561K	2	1		
0140-0031	C: fxd, mica, 220pf ±10%, 500 vdcw	76433	RCM20B221K	1	1		
0140-0032	C: fxd, mica, 47pf ±10%, 500 vdcw	76433	RCM20B470K	1	1		
0140-0035	C: fxd, mica, 39pf ±5%, 500 vdcw	76433	RCM15E390J	1	1		
0140-0041	C: fxd, mica, 100pf ±10%, 500 vdcw	76433	RCM15E101J	2	1		
0140-0071	C: fxd, sil mica, 5600pf ±1%, 500 vdcw	00656	1464TTMC24345	2	1		
0150-0011	C: fxd, TiO ₂ , 1.5pf ±20%, 500 vdcw	78488	Type GA	2	1		
0150-0012	C: fxd, cer, 0.1µf ±20%, 1000 vdcw	56289	29C214A-3-H- 1038	9	2		
0160-0050	C: fxd, paper, 0.1µf +10%, 400 vdcw	00656	V161D	5	2		
0160-0079	C: fxd, paper, 1µf ±10%, 600 vdcw	24446	23F467	1	1		
0160-0088	C: fxd, paper, 0.25µf +10%,	24446	22F21	1	1		
0160-0089	C: fxd, paper, 2 sect, 0.1 µf/sect,	00853	obd#	2	1		
0160-3192	C: fxd, paper, 0.1µf ±20%,1200vdcw	01884	LP 104 18M	1	1		
0180-0019	C: fxd, elect, 45µf -10% ±50%, 450 vdcw	14655	CE41F450R	5	2		
0180-0125	C: fxd, elect, 4 sect., 20µf/sect, 450 vdcw	00853	type PL1	2	1		
0490-0009	Relay: time delay, SPST	70563	115NO30T	1	1		
0686-1555	R: fxd, comp, 1. 5M ±5%, 1/2 W	01121	EB 1555	2	1		
0686-3635	R: fxd, comp, 36K ohms ±5%, 1/2 W	01121	EB 3635	1	1		
0687-1011	R: fxd, comp, 100 ohms ±109%, 1/2 W	01121	EB 1011	4	1		
0687-1031	R: fxd, comp, 10K ohms ±10%, 1/2 W	01121	EB 1031	2	1		
0687-1041	R: fxd, comp, 100K ohms ±10%, 1/2 W	01121	EB 1041	5	2		
0687-1051	R: fxd, comp, 1M ±10%, 1/2 W	01121	EB 1051	5	2		
0687-1221	R: fxd, comp, 1.2K ohms ±10%, 1/2 w	01121	EB 1221	2	1		
0687-1521	R: fxd, comp, 1.5K ohms ±10%, 1/2 W	01121	EB 1521	2	1		
0687-1541	R: fxd, comp, 150K ohms ±10%, 1/2 W	01121	EB 1541	2	1		
0687-1551	R: fxd, comp, 1.5M ±10%, 1/2 W	01121	EB 1551	1	1		

#See introduction to this section

Model 626A

Table 6-2. Replaceable Parts (Cont'd)

HP Stock No.	Description #	Mfr.	Mfr. Part No .	TQ	RS		
0687-2201	R: fxd, comp, 22 ohms $\pm 10\%$, 1/2 W	01121	EB 2201	1	1		
0687-2211	R: fxd, comp, 220 ohms $\pm 10\%$, 1/2 W	01121	EB 2211	1	1		
0687-2241	R: fxd, comp, 220K ohms $\pm 10\%$, 1/2 W	01121	EB 2241	2	1		
0687-2251	R: fxd, comp, 2. 2M $\pm 10\%$, 1/2 W	01121	EB 2251	1	1		
0687-2731	R: fxd, comp, 27K ohms $\pm 10\%$, 1/2 W	01121	EB 2731		1		
0687-3301	R: fxd, comp, 33 ohms $\pm 10\%$, 1/2 W	01121	EB 3301	1	1		
0687-3321	R: fxd, comp, 3.3K ohms $\pm 10\%$, 1/2 W	01121	EB 3321	1	1		
0687-3341	R: fxd, comp, 330K ohms $\pm 10\%$, 1/2 W	01121	EB 3341	1	1		
0687-3901	R: fxd, comp, 39 ohms $\pm 10\%$, 1/2 W	01121	EB 3901	1	1		
0687-3921	R: fxd, comp, 3.9K ohms $\pm 10\%$, 1/2 W	01121	EB 3921	1	1		
0687-3931	R: fxd, comp, 39K ohms $\pm 10\%$, 1/2 W	01121	EB 3931	1	1		
0687-3941	R: fxd, comp, 390K ohms $\pm 10\%$, 1/2W	01121	EB 3941	1	1		
0687-3951	R: fxd, comp, 3.9M $\pm 10\%$, 1/2 W	01121	EB 3951	1	1		
0687-4711	R: fxd, comp, 470 ohms $\pm 10\%$, 1/2 W	01121	EB 4711	1	1		
0687-4731	R: fxd, comp, 47K ohms $\pm 10\%$, 1/2 W	01121	EB 4731	2	1		
0687-5631	R: fxd, comp, 56K ohms $\pm 10\%$, 1/2 W	01121	EB 5631	1	1		
0687-6831	R: fxd, comp, 68K ohms $\pm 10\%$, 1/2 W	01121	EB 6831	1	1		
0687-8211	R: fxd, comp, 820 ohms $\pm 10\%$, 1/2 W	01121	EB 8211	1	1		
0687-8231	R: fxd, comp, 82K ohms $\pm 10\%$, 1/2 W	01121	EB 8231	1	1		
0690-1001	R: fxd, comp, 10 ohms $\pm 10\%$, 1 W	01121	GB 1001	2	1		
0690-1031	R: fxd, comp, 10K ohms $\pm 10\%$, 1 W	01121	GB 1031	3	1		
0690-1041	R: fxd, comp, 100K ohms $\pm 10\%$, 1 W	01121	GB 1041	1	1		
0690-1051	R: fxd, comp, 1M $\pm 10\%$, 1 W	01121	GB 1051	6	2		
0690-1221	R: fxd, comp, 1.2K ohms $\pm 10\%$, 1 W	01121	GB 1221	1	1		
0690-2231	R: fxd, comp, 22K ohms $\pm 10\%$, 1 W	01121	GB 2231	1	1		
0690-2241	R: fxd, comp, 220K ohms $\pm 10\%$, 1 W	01121	GB 2241	2	1		
0690-3341	R: fxd, comp, 330K ohms $\pm 10\%$, 1 W	01121	GB 3341	1	1		
0690-4751	R: fxd, comp, 3.9M $\pm 10\%$, 1 W	01121	GB 4751	1	1		
0690-4741	R: fxd, comp, 470K ohms $\pm 10\%$, 1 W	01121	GB 4741	8	3		
0690-5641	R: fxd, comp, 560K ohms $\pm 10\%$, 1 W	01121	GB 5641	1	1		
0693-1231	R: fxd, comp, 12K ohms $\pm 10\%$, 2 W	01121	HB 1231	1	1		
0693-1531	R: fxd, comp, 15K ohms $\pm 10\%$, 2 W	01121	HB 1531	1	1		
0693-1541	R: fxd comp, 150K ohms $\pm 10\%$, 2 W	01121	HB 1541	1	1		
0693-1831	R: fxd comp, 18K ohms $\pm 10\%$, 2 W	01121	HB 1831	1	1		
0693-3331	R: fxd, comp, 33K ohms $\pm 10\%$, 2 W	01121	HB 3331	1	1		
0693-3341	R: fxd, comp, 330K ohms $\pm 10\%$, 2 W	01121	GB 3341	1	1		

#See introduction to this section

Table 6-2. Replaceable Parts (Cont'd)

HP Stock No.	Description #	Mfr.	Mfr. Part No .	TQ	RS
0693-6801	R: fxd, comp, 68 ohms ±10%, 2 W	01121	HB 6801	1	1
0693-6821	R: fxd, comp, 6.8K ohms +10%, 2 W	01121	HB 6821	1	1
0727-0223	R: fxd, dep c, 216.3K ohms +1%,	19701	DC1/2BR5 obd#	1	1
0727-0244	R: fxd, dep c, 500K ohms +10%, 1/2 W	19701	DC1/2AR5 obd#	1	1
0727-0252	R: fxd, dep c, 740K ohms +1%, 1/2 W	19701	DC1/2AR5 obd#	1	1
0727-0253	R: fxd, dep c, 750K ohms +1%, 1/2 W 1/2 W	19701	DC1/2AR5 obd#	1	1
0727-0281	R: fxd, dep c, 1.39M+1%, 1/2W	19701	DC1/2AR5 obd#	1	1
0727-0291	R: fxd, dep c, 2.84M I1%, 1/2 W	19701	DC1/2R5 obd#	1	1
0727-0292	R: fxd, dep c, 3M +1%, 1/2 W	19701	DC1/2CR5 obd#	1	1
0730-0062	R: fxd, dep c, 80K ohms +1%, 1 W	19701	DC1R5 obd#	1	1
0730-0079	R: fxd, dep c, 216.3K ohms <u>+1%</u> , 1W	1S701	DC125 obd#	1	1
0730-0087	R: fxd, dep c, 370K ohms +L1%, 1 W	19701	DC1R5 obd#	1	1
0730-0092	R: fxd, dep c, 490K ohms +1%, 1 W	19701	DC1R5 obd#	1	1
0730-0096	R fxd, dep c, 683. 7K ohms +1%, 1 W	19701	DC125 obd#	1	1
0730-0100	R: fxd, dep c, 800K ohms <u>I1%</u> , 1 W	19701	DC1R5 obd#	1	1
0730-0110	R: fxd, dep c, 1.63M +1%, 1 W	19701	DC1R5 obd#	1	1
0730-0131	R: fxd, dep c, 7. 5M <u>i1%</u> , 1 W	19701	DC1R5 obd#	1	1
0770-0002	R: fxd, mfg., 2.4 ohms +5%, 4 W	07115	type LP1-4 obd#	1	1
0770-0003	R: fxd, mfg., 3.3 ohms +5%, 4 W	07115	LP1-4 obd#	1	1
0770-0004	R: fxd, mfg., 10K ohms +55%, 4 W	07115	LP1-4 obd#	1	1
0773-0009	R: fxd, mfg., 66K ohms 45%, 5 W	07115	type LP1-5 obd#	3	1
0815-0003	R: fxd, ww, 4K ohms ±5%, 10 W	75042	type 1-3/4A	1	1
0816-0006	R: fxd, ww, 5K ohms +10%, 10 W	35434	type C-10	2	1
0839-0003	Thermistor, disc	83186	27D1	2	2
0839-0022	Thermistor,	83186	32A5 04	1	0
0852-0007	Tube, ballast, No. 13-4	70563	13-4	1	1
1120-0037	Meter, PWR SET	65092	Model 506	1	1
1200-0005	Socket, tube: octal	71785	101-29-11-024	4	1
1200-0035	Socket, tube	02660	77M1P-11T	1	1
1250-0074	Connector, female: BNC	91737	UG-290/U	1	1
#See introduction to this section					
		6-11			

Model 626A Section VI

Table 6-2. Replaceable Parts (Cont'd)

HP Stock No.	Description #	Mfr.	Mfr. Part No .	TQ	RS		
1250-0075	Connector: BNC panel jack	91737	UG291/U	3	1		
1251-0006	Connector, male: 16 contact	02660	26-4100-116P	1	1		
1251-0007	Connector, female: 16 contact	02660	26-4200-165	1	1		
1251-0026	Connector, male: octal	02660	86CP11T-041-2 obd#	4	1		
1251-0052	Connector, male: 11 pin	02660	86CP11T-041-2	1	1		
1901-0029	Diode, Si	02735	obd#	14	14		
1910-0016	Diode, Ge	73293	HD2135A	1	1		
1923-0018	Tube, electron: 6AQ5	82219	obd#	1	1		
1923-0021	Tube, electron: 6AU6	82219	obd#	3	3		
1930-0013	Tube, electron: 6AL5	33173	obd#	2	2		
1930-0016	Tube, electron: 6X4	33173	obd#	1	1		
1932-0002	Tube, electron: 5687	33173	obd#	1	1		
1932-0010	Tube, electron: 6080	86684	obd#	1	1		
1932-0027	Tube, electron: 12AT7	000011	12AT7	4	4		
1940-0001	Tube, electron: 5651	86684	5651	1	1		
1940-0004	Tube, electron: OA2	86684	obd#	1	1		
1941-0003	Tube, electron: 5696	86684	5696	2	2		
2100-0014	R: var, comp, 200K ohms +20%	11237	obd#	2	1		
2100-0025	R: var, comp, lin, 1.5K ohms +10%	01121	JA1L0405152Z	1	1		
2100-0028	R: var, comp, 50K ohms ±10%	01121	JAZL0485503UC	5	2		
2100-0034	R: var, comp, lin, 250K ohms +109%	11237	type 35	2	1		
2100-0036	R: var, comp, lin, 1K ohms	71590	obd#	1	1		
2100-0045	R: var, comp, 100K ohms ±10%	01121	JA1N056S104AA	1	1		
2100-0047	R: var, 1M ±20%, 2 W	01121	JA1N056S105RZ	1	1		
2100-0068	R: var, comp, lin, 500 ohms	01121	JA1L048S501UC	1	1		
2100-0096	R: var, comp, lin, 1M ±30%, 1/4 W	11237	UPE-70 special	3	2		
2100-0098	R: var, comp, lin, 20K ohms +20%	11237	UPM-45	1	1		
2100-0120	R: var, ww, 100K ohms tapped at 50K	98734	obd#	1	1		
2110-0015	Fuse, cartridge: 2.5 amp, s-b (For 115 V operation)	75915	31302.5	1	10		
2110-0021	Fuse, cartridge: 1.25 amp, s-b (For 230 V operation)	71400	MDL 1.25				

#See introduction to this section

Table 6-2. Replaceable Parts (Cont'd)

HP Stock No.	Description #	Mfr.	Mfr. Part No .	TQ	RS		
2140-0009	Lamp, inccd: 6-8V type 47	24455	47	1	1		
3100-0111	Switch, rot: (MOD SEL) 3 sect	76854	68732-F3	1	1		
3100-0121	Switch, rot: (SYNC SEL.) 2 sect	76854	68731-F2	1	1		
3101-0030	Switch, tog: SPST	04009	82601	1	1		
3102-0001	Switch, micro SPDT, 10 amp	91929	BZ-2RS	1	1		
3102-0002	S4 Actuator	91929	JR				
3140-0010	Motor, fan	73793	G5-CW ER-6667	1	1		
3160-0012	Blade, fan	06812	0-5527-5	1	1		
7.5ft. 8120-0015	Power cable	70903	KH3981/PH7C/	1	1		
9100-0114	Transformer, power	98734	9018	1	1		
9100-0115	Transformer, power	98734	9017	1	1		
9110-0011	Reactor, filter: 6 h	98734	1009	1	1		
9140-0019	Inductor, RF: 200 μh	99848	1200-15-201	2	1		
9140-0020	Inductor, RF: 400 μh	99848	1400-15-401	1	1		
9140-0021	Inductor, RF: 430 μh	99848	3430-15-431	1	1		
9140-0022	Inductor, RF: 500 μh	99848	150-15-501	1	1		
MISCELLANEOUS							
G-32H	Coupler, plastic, control shaft (FM AMP, PHASE MOD SEL)	28480	G-32H	2	1		
G-74F	Knob: ZERO SET, OUTPUT ATTEN	28480	G-74F	2	1		
G-74G	Knob: PWR SET, FM AMP, FM PHASE	28480	G-74G	3	1		
G-74H	Knob: PULSE RATE, PULSEDELAY, PULSE WIDTH(stake on)	28480	G-74H	3	1		
G-74N	Knob: SYNC SELECTOR, MOD SELECTOR	28480	G-74N	2	1		
626A-28	Thermistor mount assy	28480	626A-28	1	1		
626A-32C	Output connector, waveguide	28480	626A-32C	1	1		

#See introduction to this section

Table 6-2. Replaceable Parts (Cont'd)

HP Stock No.	Description #	Mfr.	Mfr. Part No .	TQ	RS		
626A-38A	Wrench, spanner	28480	626A-38A	1	1		
626A-38B-1	Screwdriver	28480	626A-38B-1	1	1		
626A-38B-2	Wrench Assembly: Tube	28480	626A-38B-2	1			
626A-95A	Klystron cavity assy complete w/	28480	626A-95A	1	1		
W33M-2	Cap, waveguide, plastic molding	28480	4133-0005	1	1		
W34M-1	Plug, waveguide (low dielectric loss)	28480	4054-0003	2	1		
1400-0084	Fuseholder	75915	342014	1	1		
3150-0002	Air Filter Adhesive water soluble; 16.5 fl. oz can equipped with sprayer applicator. Super Filter Coat Brand	82866	obd#	0	1		
626A-65D	Printed circuit board, pulse section complete with components	28480		1			
626A-65E	Printed circuit board, power supply section, complete with components	28480		1			
626A-65F	Printed circuit board, modulator section, complete with components	28480		1			

#See introduction to this section

**APPENDIX A
REFERENCES**

DA Pam 310-4	Index of Technical Publications: Technical Manuals, Technical Bulletins, Supply Manuals (Types 7, 8, and 9), Supply Bulletins, and Lubrication Work Orders.
DA Pam 310-7	Index of Modification Work Orders.
TB 9-6625-776-50	Calibration Procedures for Generator, Signal AN, USM-47.
TM 11-6625-2910-14-HR	Hand Receipt Manual Covering End Item/Components of End Item (COEI), Basic Issue Items (BII), and Additional Authorization List (AAL) for Signal Generator AN/USM-47 (NSN 6625-00-445-6917). (To be published.)
TM 11-6625-2910-24P	Organizational, Direct Support and General Support Maintenance Repair Parts and Special Tools Lists for Signal Generator AN/USM-47 (HP626A) (NSN 6625-00-445-6917).
TM 38750	The Army Maintenance Management System (TAMMS).
TM 740-90-1	Administrative Storage of Equipment.
TM 750-244-2 (Electronics Command).	Procedures for Destruction of Electronics Materiel to Prevent Enemy Use

Change 1 A-1/(A-2 blank)

APPENDIX B COMPONENTS OF END ITEM LIST

SECTION I. INTRODUCTION

B-1. Scope

This appendix lists integral components of and basic issue items for the AN/USM-47 to help you inventory items required for safe and efficient operation.

5-2. General

This Components of End Item List is divided into the following sections:

a. Section II. Integral Components of the End Item. These items, when assembled, comprise the NA/USM-47 in operation, to operate it, and to transferred or turned in. The illustrations will help transferred or turned identify these illustrations will help

b. Section III. Basic Issue Items. These are the minimum essential items required to place the AN/USM-47 in operation, to operate it, and to AperformN/USM-47 in operation, to operate it, and to perform emergency repairs. Although shipped separately packed they must accompany the AN/USM-47 during operation and whenever it is transferred between accountable officers. The illustrations will assist you with hard-to-identify items. This manual is your authority to requisition replacement BII, based on TOE/MTOE authorization of the end item

B-3. Explanation of Columns

a. Illustration. This column is divided as follows:

(1) Figure number. Indicates the figure number of the illustration on which the item is shown.

(2) Item number. The number used to identify item called out in the illustration.

b. National Stock Number. Indicates the National stock number assigned to the item and which will be used for requisitioning.

c. Description. Indicates the Federal item name and, if required, a minimum description to identify the item. The part number indicates the primary number used by the manufacturer, which controls the design and characteristics of the item by means of its engineering drawings, specifications, standards, and inspection requirements to identify an item or range of items. Following the part number, the Federal Supply Code for Manufacturers (FSCM) is shown in parentheses.

d. Locations. The physical location of each item listed is given in this column. The lists are designed to inventory all items in one area of the major item before moving on to an adjacent area. B-1 before moving on to an adjacent area.

e. Usable on Code. Not applicable.

f. Quantity Required (Qty Reqd). This column lists the quantity of each item required for a

g. Quantity. This column is left blank for use during an inventory. Under the Rcvd column, list the quantity you actually receive on your major item. The Date columns are for your use when you inventory the major item.

(Next printed page is B-2)

SECTION II. INTEGRAL COMPONENTS OF END ITEM

(1) ILLUSTRATION		(2) NATIONAL STOCK NUMBER	(3) DESCRIPTION		(4) LOCATION	(5) USUABLE ON CODE	(6) QTY REQD	(7) QUANTITY	
(A) FIG.	(B) ITEM		PART NUMBER	FSCM				RCVD	DATE
1-1		6625-00-445-6917	SIGNAL GENERATOR AN/USM-47 (HP626A) (28480)						
			B-2						

SECTION III. BASIC ISSUE ITEMS

(1) ILLUSTRATION		(2) NATIONAL STOCK NUMBER	(3) DESCRIPTION		(4) LOCATION	(5) USUABLE ON CODE	(6) QTY REQD	(7) QUANTITY	
(A) FIG.	(B) ITEM		PART NUMBER	CAGE				RCVD	DATE
3-1		5920-00-280-3178	FUSE, CARMTDG (FOR 115Y), 2.5 AMPS 31302.5	(75915)			1		
3-1		5920-00-131-9817	FSE, CARTRIDG (FOR 230Y), 1.25 AMPS MDL 1.25	(71400)			1		

APPENDIX D

MAINTENANCE ALLOCATION

SECTION I. INTRODUCTION

D-1. General.

This appendix provides a summary of the maintenance operations for Signal Generator AN/USM-47. It authorizes categories of maintenance for specific maintenance functions on repairable items and components and the tools and equipment required to perform each function. This appendix may be used as an aid in planning maintenance operations.

D-2. Maintenance Function.

Maintenance functions will be limited to and defined as follows:

a. Inspect. To determine the serviceability of an item by comparing its physical, mechanical, and/or electrical characteristics with established standards through examination.

b. Test. To verify serviceability and to detect incipient failure by measuring the mechanical or electrical characteristics of an item and comparing those characteristics with prescribed standards.

c. Service. Operations required periodically to keep an item in proper operating condition, i.e., to clean (decontaminate), to preserve, to drain, to paint, or to replenish fuel, lubricants, hydraulic fluids, or compressed air supplies.

d. Adjust. To maintain, within prescribed limits, by bringing into proper or exact position, or by setting the operating characteristics to the specified parameters.

e. Align. To adjust specified variable elements of an item to bring about optimum or desired performance.

f. Calibrate. To determine and cause corrections to be made or to be adjusted on instruments or test measuring and diagnostic equipments used in precision measurement. Consists of comparisons of two instruments, one of which is a certified standard of known accuracy, to detect and adjust any discrepancy in the accuracy of the instrument being compared.

g. Install. The act of emplacing, seating, or fixing into position an item, part, module (component or assembly) in a manner to allow the proper functioning of the equipment or system.

h. Replace. The act of substituting a serviceable like type part, subassembly, or module (component or assembly) for an unserviceable counterpart.

i. Repair. The application of maintenance services (inspect, test, service, adjust, align, calibrate, replace) or other maintenance actions (welding, grinding, riveting, straightening, facing, remachining, or resurfacing) to restore serviceability to an item by correcting specific damage, fault, malfunction, or failure in a part, subassembly, module (component or assembly), end item, or system.

j. Overhaul. That maintenance effort (service/action) necessary to restore an item to a completely serviceable/operational condition as prescribed by maintenance standards (i.e., DMWR) in appropriate technical publications. Overhaul is normally the highest degree of maintenance performed by the Army. Overhaul does not normally return an item to like new condition.

k. Rebuild. Consists of those services/actions necessary for the restoration of unserviceable equipment to a like new condition in accordance with original manufacturing standards. Rebuild is the highest degree of material maintenance applied to Army equipment. The rebuild operation includes the act of returning to zero those age measurements (hours, miles, etc.) considered in classifying Army equipments/components.

D-3. Column Entries.

a. Column 1, Group Number. Column 1 lists group numbers, the purpose of which is to identify components, assemblies, subassemblies, and modules with the next higher assembly.

b. Column 2, Component/Assembly. Column 2 contains the noun names of components, assemblies, subassemblies, and modules for which maintenance is authorized.

c. Column 3, Maintenance Functions. Column 3 lists the functions to be performed on the item listed in column 2. When items are listed without maintenance functions, it is solely for purpose of having the group numbers in the MAC and RPSTL coincide.

Model 626A

d. Column 4, Maintenance Category. Column 4 specifies, by the listing of a "work time" figure in the appropriate subcolumn(s), the lowest level of maintenance authorized to perform the function listed in column 3. This figure represents the active time required to perform that maintenance function at the indicated category of maintenance. If the number or complexity of the tasks within the listed maintenance function vary at different maintenance categories, appropriate "work time" figures will be shown for each category. The number of task-hours specified by the "work time" figure represents the average time required to restore an item (assembly, subassembly, component, module, end item or system) to a serviceable condition under typical field operating conditions. This time includes preparation time, troubleshooting time, and quality assurance/ quality control time in addition to the time required to perform the specific tasks identified for the maintenance functions authorized in the maintenance allocation chart. Subcolumns of column

4-are as follows:

- C-Operator/Crew
- O-Organizational
- F-Direct Support
- H-General Support
- D-Depot

e. Column 5, Tools and Equipment. Column 5 specifies by code, those common tool sets (not individual tools) and special tools, test, and support equipment required to perform the designated function.

f. Column 6, Remarks. Column 6 contains an alphabetic code which leads to the remark in section IV, Remarks, which is pertinent to the item opposite the particular code.

D-4. Tool and Test Equipment Requirements (section III).

a. Tool and Test Equipment Reference Code. The numbers in this column coincide with the numbers used in the tools and equipment column of the MAC. The numbers indicate the applicable tool or test equipment for the maintenance functions.

b. Maintenance Category. The codes in this column indicate the maintenance category allocated the tool or test equipment.

c. Nomenclature. This column lists the noun name and nomenclature of the tools and test equipment required to perform the maintenance functions.

d. National/NATO Stock Number. This column lists the National/NATO stock number of the specific tool or test equipment.

e. Tool Number. This column lists the manufacturer's part number of the tool followed by the Federal Supply Code for manufacturers (5-digit) in parentheses.

D-5. Remarks.

a. Reference Code. This code refers to the appropriate item in section II, column 6.

b. Remarks. This column provides the required explanatory information necessary to clarify items appearing in section II.

**SECTION II. MAINTENANCE ALLOCATION CHART
FOR
SIGNAL GENERATOR AN/USM-47**

(1) Group number	(2) Component/assembly	(3) Maint. function	(4) Maint. category					(5) Tool/ equipment	(6) Remarks
			C	O	F	H	D		
00	SIGNAL GENERATOR, AR/US47 (HP 626A)	Inspect Test Service Adjust Install Replace Repair Overhaul		0.3 0.3 0.3		0.5 0.5 7.0 2.5		1 thru 14 1 1 thru 14 1 1 1 1 thru 14	
01	CIRCUIT CARD ASSMBLY, PLSE SECTION, A1	Inspect Replace Repair				0.3 0.5 0.5			
02	CIRCUIT CARD ASSEMBLY, POWER REGULATOR, A2	Inspect Replace Repair			0.3	0.5 0.5		1 1	
03	CIRCUIT CARDI ASSEMBLY, NODULATOR, A3	Inspect Replace Repair			0.3 0.75 1.5			1 1	
04	KLYSTROR ASSEMBLY, A4	Inspect Test Replace Repair			0.3 0.5 0.5			1 thru 14	
		D-3							A

**SECTION III. TOOL AND TEST EQUIPMENT REQUIREMENTS
FOR
SIGNAL GENERATOR USM-47**

(1) TOOL OR TEST EQUIPMENT REF CODE	(2) MAINTENANCE LEVEL	(3) NOMENCLATURE	(4) NATIONAL/NATO STOCK NUMBER	(5) TOOL NUMBER
1	H, D	TOOL KIT, ELECTRONIC EQUIPMEUT T-105/G	5180-o0o-81T7	
2	H, D	MULTIMETER AN/USM-223A	6625-00-999-7465	
3	H, D	OSCILLOSCOPE, HEWLETT-PACKARD 160B	6625-00-291-1029	
4	H, D	AUDIO OSCILLATOR, HEWLETT-PACKARD 200AB	66254)0-519-2384	
5	H, D	PULSE GENERATOR, HEWLETPACKARD 212A	6625-00-519-5593	
6	H, D	VACUUM TUBE VOLTMETER, HEWLET-PACKARD 40OU/H	6625-o00-643-1670o	
7	H, D	VACUUM TUBE VOLTMETER, HEWLETT-PACKARD 410B	6625-00-360-2493	
B	H, D	MICROWAVE POWER METER, HEWLETT-PACKARD 430C	6625-00-851-4403	
9	H, D	CRYSTAL DETECTOR, HEWLETT-PACKARD M421A	5961-00-86T76990	
10	H, D	CRYSTAL DETECTOR, HEILE-T-PACKARD P421A	6625-oo-980-9302	
11	H, D	THERIMSTOR NOUNT, HEWLETT-PACKARD M48TB	6625-00-887-7771	
12	H, D	THERMISTOR KUT, HEWLET-PACKARD P487B	6625-00-618-9192	
13	H, D	REPUENCY KMEER, HEWLE-PACKARD M532	6625-00-236-8643	
14	H, D	FREQUENCY METER, HIELETT-PAC KARD P532A	6625-oo-691-6598	

SECTION IV. REMARKS

REFERENCE CODE	REMARKS
A	RETURN TO HMUFAUR FOR REPAIR

APPENDIX F
CODE LIST OF MANUFACTURERS (Sheet 1 of 2)

The following code numbers are from the Federal Supply Code for Manufacturers Cataloging Handbooks H4-1 (Name to Code) and H4-2 (Code to Name) and their latest supplements. The date of revision and the date of the supplements used appear at the bottom of each page. Alphabetical codes have been arbitrarily assigned to suppliers not appearing in the H4 handbooks.

CODE NO.	MANUFACTURER	ADDRESS	CODE NO.	MANUFACTURER	ADDRESS	CODE NO.	MANUFACTURER	ADDRESS
00334	Humidial Co.	Colton, Calif.	07126	Digitran Co.	Pasadena, Calif.	42190	Muter Co.	Chicago, Ill.
00335	Westrex Corp.	New York, N.Y.	07137	Transistor Electronics Corp.	Minneapolis, Minn.	43990	C. A. Norgren Co.	Englewood, Colo.
00373	Garlock Packing Co., Electronic Products Div.	Camden, N.J.	07138	Westinghouse Electric Corp. Electronic Tube Div.	Elmira, N.Y.	44655	Ohmite Mfg. Co.	Skokie, Ill.
00656	Aerovox Corp.	New Bedford, Mass.	07261	Avnet Corp.	Los Angeles, Calif.	47904	Polaroid Corp.	Cambridge, Mass.
00779	Amp. Inc.	Harrisburg, Pa.	07263	Fairchild Semiconductor Corp.	Mountain View, Calif.	48620	Precision Thermometer and Inst. Co.	Philadelphia, Pa.
00781	Aircraft Radio Corp.	Boonton, N.J.	07910	Continental Device Corp.	Hawthorne, Calif.	49956	Raytheon Company	Lexington, Mass.
00853	Sangamo Electric Company, Ordill Division (Capacitors)	Marion, Ill.	07933	Rheem Semiconductor Corp.	Mountain View, Calif.	54294	Shallcross Mfg. Co.	Selma, N.C.
00866	Goe Engineering Co.	Los Angeles, Calif.	07966	Shockley Semi-Conductor Laboratories	Palo Alto, Calif.	55026	Simpson Electric Co.	Chicago, Ill.
00891	Carl E. Holmes Corp.	Los Angeles, Calif.	07980	Boonton Radio Corp.	Boonton, N.J.	55933	Sonotone Corp.	Elmsford, N.Y.
01121	Allen Bradley Co.	Milwaukee, Wis.	08145	U.S. Engineering Co.	Los Angeles, Calif.	55938	Sorenson & Co., Inc.	So. Norwalk, Conn.
01255	Litton Industries, Inc.	Beverly Hills, Calif.	08358	Burgess Battery Co.	Niagara Falls, Ontario, Canada	56137	Spaulding Fibre Co., Inc.	Tonawanda, N.Y.
01281	Pacific Semiconductors, Inc.	Culver City, Calif.	08717	Sloan Company	Burbank, Calif.	56289	Sprague Electric Co.	North Adams, Mass.
01295	Texas Instruments, Inc. Transistor Products Div.	Dallas, Texas	08718	Cannon Electric Co. Phoenix Div.	Phoenix, Ariz.	59446	Telex, Inc.	St. Paul, Minn.
01349	The Alliance Mfg. Co.	Alliance, Ohio	08792	CBS Electronics Semiconductor Operations, Div. of C.B.S. Inc.	Lowell, Mass.	61775	Union Switch and Signal, Div. of Westinghouse Air Brake Co.	Swissvale, Pa.
01561	Chassi-Trak Corp.	Indianapolis, Ind.	08984	Mel-Rain	Indianapolis, Ind.	62119	Universal Electric Co.	Owosso, Mich.
01589	Pacific Relays, Inc.	Van Nuys, Calif.	09026	Babcock Relays, Inc.	Costa Mesa, Calif.	64959	Western Electric Co., Inc.	New York, N.Y.
01930	Amerock Corp.	Rockford, Ill.	09134	Texas Capacitor Co.	Houston, Texas	65092	Weston Inst. Div. of Daystrom, Inc.	Newark, N.J.
01961	Pulse Engineering Co.	Santa Clara, Calif.	09250	Electro Assemblies, Inc.	Chicago, Ill.	66346	Wollensak Optical Co.	Rochester, N.Y.
02114	Ferroxcube Corp. of America	Saugerties, N.Y.	09569	Mallory Battery Co. of Canada, Ltd.	Toronto, Ontario, Canada	70276	Allen Mfg. Co.	Hartford, Conn.
02286	Cole Mfg. Co.	Palo Alto, Calif.	10214	General Transistor Western Corp.	Los Angeles, Calif.	70309	Allied Control Co., Inc.	New York, N.Y.
02660	Amphenol-Borg Electronics Corp.	Chicago, Ill.	10411	Ti-Tal, Inc.	Berkeley, Calif.	70485	Atlantic India Rubber Works, Inc.	Chicago, Ill.
02735	Radio Corp. of America Semiconductor and Materials Div.	Somerville, N.J.	10646	Carborundum Co.	Niagara Falls, N.Y.	70563	Amperite Co., Inc.	New York, N.Y.
02771	Vocaline Co. of America, Inc.	Old Saybrook, Conn.	11236	CTS of Berne, Inc.	Berne, Ind.	70903	Belden Mfg. Co.	Chicago, Ill.
02777	Hopkins Engineering Co.	San Fernando, Calif.	11237	Chicago Telephone of California, Inc.	So. Pasadena, Calif.	70998	Bird Electronic Corp.	Cleveland, Ohio
03508	G.E. Semiconductor Products Dept.	Syracuse, N.Y.	11312	Microwave Electronics Corp.	Palo Alto, Calif.	71002	Birnbach Radio Co.	New York, N.Y.
03705	Apex Machine & Tool Co.	Dayton, Ohio	11534	Duncan Electronics, Inc.	Santa Ana, Calif.	71041	Boston Gear Works Div. of Murray Co. of Texas	Quincy, Mass.
03797	Eidema Corp.	El Monte, Calif.	11711	General Instrument Corporation Semiconductor Division	Newark, N.J.	71218	Bud Radio Inc.	Cleveland, Ohio
03877	Transitron Electronic Corp.	Wakefield, Mass.	11717	Imperial Electronics, Inc.	Buena Park, Calif.	71286	Camloc Fastener Corp.	Paramus, N.J.
03888	Pyrofilm Resistor Co.	Morristown, N.J.	11870	Melabs, Inc.	Palo Alto, Calif.	71313	Allen D. Cardwell Electronic Prod. Corp.	Plainville, Conn.
03954	Air Marine Motors, Inc.	Los Angeles, Calif.	12697	Clarostat Mfg. Co.	Dover, N.H.	71400	Bussmann Fuse Div. of McGraw- Edison Co.	St. Louis, Mo.
04009	Arrow, Hart and Hegeman Elct. Co.	Hartford, Conn.	14655	Cornell Dubilier Elec. Corp.	So. Plainfield, N.J.	71450	CTS Corp.	Elkhart, Ind.
04062	Elmenco Products Co.	New York, N.Y.	15909	The Daven Co.	Livingston, N.J.	71468	Cannon Electric Co.	Los Angeles, Calif.
04222	Hi-Q Division of Aerovox	Myrtle Beach, S.C.	16688	De Jur-Amsco Corporation	Long Island City 1, N.Y.	71471	Cinema Engineering Co.	Burbank, Calif.
04298	Elgin National Watch Co., Electronics Division	Burbank, Calif.	16758	Delco Radio Div. of G. M. Corp.	Kokomo, Ind.	71482	C. P. Clare & Co.	Chicago, Ill.
04404	Dymec Division of Hewlett-Packard Co.	Palo Alto, Calif.	18873	E. I. DuPont and Co., Inc.	Wilmington, Del.	71528	Standard-Thomson Corp., Clifford Mfg. Co. Div.	Waltham, Mass.
04651	Sylvania Electric Prods., Inc. Electronic Tube Div.	Mountain View, Calif.	19315	Eclipse Pioneer, Div. of Bendix Aviation Corp.	Teterboro, N.J.	71590	Centralab Wire of Globe Union Inc.	Milwaukee, Wis.
04713	Motorola, Inc., Semiconductor Prod. Div.	Phoenix, Arizona	19500	Thomas A. Edison Industries, Div. of McGraw-Edison Co.	West Orange, N.J.	71700	The Cornish Wire Co.	New York, N.Y.
04732	Filtron Co., Inc. Western Division	Culver City, Calif.	19701	Electra Manufacturing Co.	Kansas City, Mo.	71744	Chicago Miniature Lamp Works	Chicago, Ill.
04773	Automatic Electric Co.	Northlake, Ill.	20183	Electronic Tube Corp.	Philadelphia, Pa.	71753	A. O. Smith Corp., Crowley Div.	West Orange, N.J.
04796	Sequoia Wire & Cable Company	Redwood City, Calif.	21520	Fansteel Metallurgical Corp.	No. Chicago, Ill.	71785	Cinch Mfg. Corp.	Chicago, Ill.
04870	P. M. Motor Co.	Chicago, Ill.	21335	The Fafnir Bearing Co.	New Britain, Conn.	71984	Dow Corning Corp.	Midland, Mich.
05006	Twentieth Century Plastics, Inc.	Los Angeles, Calif.	21964	Fed. Telephone and Radio Corp.	Clifton, N.J.	72136	Electro Motive Mfg. Co., Inc.	Willimantic, Conn.
05277	Westinghouse Electric Corp., Semi-Conductor Dept.	Youngwood, Pa.	24446	General Electric Co.	Schenectady, N.Y.	72354	John E. Fast & Co.	Chicago, Ill.
05347	Ultronix, Inc.	San Mateo, Calif.	24455	G.E., Lamp Division	Nela Park, Cleveland, Ohio	72619	Dialight Corp.	Brooklyn, N.Y.
05593	Illumintronic Engineering Co.	Sunnyvale, Calif.	24655	General Radio Co.	West Concord, Mass.	72656	General Ceramics Corp.	Keasbey, N.J.
05624	Barber Colman Co.	Rockford, Ill.	24662	Grobet File Co. of America, Inc.	Carlstadt, N.J.	72758	Girard-Hopkins	Oakland, Calif.
05729	Metropolitan Telecommunications Corp., Metro Cap. Div.	Brooklyn, N.Y.	26992	Hamilton Watch Co.	Palo Alto, Calif.	72765	Drake Mfg. Co.	Chicago, Ill.
05783	Stewart Engineering Co.	Santa Cruz, Calif.	28480	Hewlett-Packard Co.	Palo Alto, Calif.	72825	Hugh H. Eby Inc.	Philadelphia, Pa.
06004	The Bassick Co.	Bridgport, Conn.	33173	G.E. Receiving Tube Dept.	Owensboro, Ky.	72928	Gudeman Co.	Chicago, Ill.
06555	Beede Electrical Instrument Co., Inc.	Penacook, N.H.	35434	Lectrohm Inc.	Chicago, Ill.	72982	Erie Resistor Corp.	Erie, Pa.
06812	Torrington Mfg. Co., West Div.	Van Nuys, Calif.	37942	P. R. Mallory & Co., Inc.	Indianapolis, Ind.	73061	Hansen Mfg. Co., Inc.	Princeton, Ind.
07115	Corning Glass Works Electronic Components Dept.	Bradford, Pa.	39543	Mechanical Industries Prod. Co.	Akron, Ohio	73138	Hellipot Div. of Beckman Instruments, Inc.	Fullerton, Calif.
			40920	Miniature Precision Bearings, Inc.	Keene, N.H.	73293	Hughes Products Division of Hughes Aircraft Co.	Newport Beach, Calif.
						73445	Amperex Electronic Co., Div. of North American Phillips Co., Inc.	Hicksville, N.Y.
						73506	Bradley Semiconductor Corp.	Hamden, Conn.
						73559	Carling Electric, Inc.	Hartford, Conn.
						73682	George K. Garrett Co., Inc.	Philadelphia, Pa.
						73734	Federal Screw Products Co.	Chicago, Ill.
						73743	Fischer Special Mfg. Co.	Cincinnati, Ohio
						73793	The General Industries Co.	Elyria, Ohio

From: F.S.C. Handbook Supplements
H4-1 Dated February 1962
H4-2 Dated January 1962

00015-23
Revised: 30 March 1962

APPENDIX F
CODE LIST OF MANUFACTURERS (Sheet 2 of 2)

CODE NO.	MANUFACTURER	ADDRESS	CODE NO.	MANUFACTURER	ADDRESS	CODE NO.	MANUFACTURER	ADDRESS
73905	Jennings Radio Mfg. Co.	San Jose, Calif.	82647	Metals and Controls, Inc., Div. of Texas Instruments, Inc., Spencer Prods.	Attleboro, Mass.	95263	Leecraft Mfg. Co., Inc.	New York, N.Y.
74455	J. H. Winns, and Sons	Winchester, Mass.	82866	Research Products Corp.	Madison, Wis.	95264	Lerco Electronics, Inc.	Burbank, Calif.
74861	Industrial Condenser Corp.	Chicago, Ill.	82877	Rotron Manufacturing Co., Inc.	Woodstock, N.Y.	95265	National Coil Co.	Sheridan, Wyo.
74868	R.F. Products Division of Amphenol-Borg Electronics Corp.	Danbury, Conn.	82893	Vector Electronic Co.	Glendale, Calif.	95275	Vitramon, Inc.	Bridgeport, Conn.
74970	E. F. Johnson Co.	Waseca, Minn.	83053	Western Washer Mfr. Co.	Los Angeles, Calif.	95354	Methode Mfg. Co.	Chicago, Ill.
75042	International Resistance Co.	Philadelphia, Pa.	83058	Carr Fastener Co.	Cambridge, Mass.	95987	Weckesser Co.	Chicago, Ill.
75173	Jones, Howard B., Division of Cinch Mfg. Corp.	Chicago, Ill.	83086	New Hampshire Ball Bearing, Inc.	Peterborough, N.H.	96067	Huggins Laboratories	Sunnyvale, Calif.
75378	James Knights Co.	Sandwich, Ill.	83125	Pyramid Electric Co.	Darlington, S.C.	96095	Hi-Q Division of Aerovox	Olean, N.Y.
75382	Kulka Electric Corporation	Mt. Vernon, N.Y.	83148	Electro Cords Co.	Los Angeles, Calif.	96256	Thordarson-Meissner Div. of Maguire Industries, Inc.	Mt. Carmel, Ill.
75818	Lenz Electric Mfg. Co.	Chicago, Ill.	83186	Victory Engineering Corp.	Union, N.J.	96296	Solar Manufacturing Co.	Los Angeles, Calif.
75915	Littelfuse Inc.	Des Plaines, Ill.	83298	Bendix Corp., Red Bank Div.	Red Bank, N.J.	96330	Carlton Screw Co.	Chicago, Ill.
76005	Lord Mfg. Co.	Erie, Pa.	83330	Smith, Herman H., Inc.	Brooklyn, N.Y.	96341	Microwave Associates, Inc.	Burlington, Mass.
76210	C. W. Marwedel	San Francisco, Calif.	83501	Gavitt Wire and Cable Co., Div. of Amerace Corp.	Brookfield, Mass.	96501	Excel Transformer Co.	Oakland, Calif.
76433	Micamold Electronic Mfg. Corp.	Brooklyn, N.Y.	83594	Burroughs Corp., Electronic Tube Div.	Plainfield, N.J.	97464	Industrial Retaining Ring Co.	Irvington, N.J.
76487	James Millen Mfg. Co., Inc.	Malden, Mass.	83777	Model Eng. and Mfg., Inc.	Huntington, Ind.	97539	Automatic and Precision Mfg. Co.	Yonkers, N.Y.
76493	J. W. Miller Co.	Los Angeles, Calif.	83821	Loyd Scruggs Co.	Festus, Mo.	97966	CBS Electronics, Div. of C.B.S., Inc.	Danvers, Mass.
76530	Monadnock Mills	San Leandro, Calif.	84171	Arco Electronics, Inc.	New York, N.Y.	98141	Axel Brothers Inc.	Jamaica, N.Y.
76545	Mueller Electric Co.	Cleveland, Ohio	84396	A. J. Glesener Co., Inc.	San Francisco, Calif.	98220	Francis L. Mosley	Pasadena, Calif.
76854	Oak Manufacturing Co.	Crystal Lake, Ill.	84411	Good All Electric Mfg. Co.	Ogallala, Neb.	98278	Microdot, Inc.	So. Pasadena, Calif.
77068	Bendix Pacific Division of Bendix Corp.	No. Hollywood, Calif.	84970	Sarkes Tarzian, Inc.	Bloomington, Ind.	98291	Seaelectro Corp.	Mamaroneck, N.Y.
77221	Phaostron Instrument and Electronic Co.	South Pasadena, Calif.	85454	Bounton Molding Company	Boonton, N.J.	98405	Carad Corp.	Redwood City, Calif.
77252	Philadelphia Steel and Wire Corp.	Philadelphia, Pa.	85474	R. M. Bracamonte & Co.	San Francisco, Calif.	98734	Palo Alto Engineering Co., Inc.	Palo Alto, Calif.
77342	Potter and Brumfield, Div. of American Machine and Foundry	Princeton, Ind.	85660	Koiled Kords, Inc.	New Haven, Conn.	98821	North Hills Electric Co.	Mineola, N.Y.
77630	Radio Condenser Co.	Camden, N.J.	85911	Seamless Rubber Co.	Chicago, Ill.	98925	Clevite Transistor Prod. Div. of Clevite Corp.	Waltham, Mass.
77638	Radio Receptor Co., Inc.	Brooklyn, N.Y.	86197	Clifton Precision Products	Clifton Heights, Pa.	98978	International Electronic Research Corp.	Burbank, Calif.
77764	Resistance Products Co.	Harrisburg, Pa.	86684	Radio Corp. of America, RCA Electronic Tube Div.	Harrison, N.J.	99109	Columbia Technical Corp.	New York, N.Y.
78189	Shakeproof Division of Illinois Tool Works	Elgin, Ill.	87216	Philco Corp. (Lansdale Division)	Lansdale, Pa.	99313	Varian Associates	Palo Alto, Calif.
78283	Signal Indicator Corp.	New York, N.Y.	87473	Western Fibrous Glass Products Co.	San Francisco, Calif.	99515	Marshall Industries, Electron Products Division	Pasadena, Calif.
78471	Tilley Mfg. Co.	San Francisco, Calif.	88140	Cutler-Hammer, Inc.	Lincoln, Ill.	99707	Control Switch Division, Controls Co. of America	El Segundo, Calif.
78488	Stackpole Carbon Co.	St. Marys, Pa.	88220	Gould-National Batteries, Inc.	St. Paul, Minn.	99800	Delevan Electronics Corp.	East Aurora, N.Y.
78553	Tinnerman Products, Inc.	Cleveland, Ohio	89473	General Electric Distributing Corp.	Schenectady, N.Y.	99848	Wilco Corporation	Indianapolis, Ind.
78790	Transformer Engineers	Pasadena, Calif.	89636	Carter Parts Div. of Economy	Baler Co. Chicago, Ill.	99934	Renbrandt, Inc.	Boston, Mass.
78947	Ucinite Co.	Newtonville, Mass.	90179	U.S. Rubber Co., Mechanical Goods Div.	Passaic, N.J.	99942	Hoffman Semiconductor Div. of Hoffman Electronics Corp.	Evanston, Ill.
79142	Veeder Root, Inc.	Hartford, Conn.	90970	Bearing Engineering Co.	San Francisco, Calif.		Technology Instrument Corp. of Calif.	Newbury Park, Calif.
79251	Wenco Mfg. Co.	Chicago, Ill.	91260	Connor Spring Mfg. Co.	San Francisco, Calif.			
79727	Continental-Wirt Electronics Corp.	Philadelphia, Pa.	91418	Radio Materials Co.	Chicago, Ill.	3000 F	Malco Tool and Die	Los Angeles, Calif.
79963	Zierick Mfg. Corp.	New Rochelle, N.Y.	91506	Augat Brothers, Inc.	Attleboro, Mass.	0000 I	Telefunken (c/o American Elite)	New York, N.Y.
80031	Mecco Division of Sessions Clock Co.	Morristown, N.J.	91637	Dala Electronics, Inc.	Columbus, Nebr.	0000 M	Western Coil Div. of Automatic Ind., Inc.	Redwood City, Calif.
80120	Schnitzer Alloy Products	Elizabeth, N.J.	91662	Elco Corp.	Philadelphia, Pa.	0000 N	Nahm-Bros. Spring Co.	San Leandro, Calif.
80130	Times Facsimile Corp.	New York, N.Y.	91737	Gremer Mfg. Co., Inc.	Wakefield, Mass.	0000 P	Ty-Car Mfg. Co., Inc.	Holliston, Mass.
80131	Electronic Industries Association Any brand tube meeting EIA standards	Washington, D.C.	91827	K F Development Co.	Redwood City, Calif.	0000 T	Texas Instruments, Inc. Metals and Controls Div.	Versailles, Ky.
80207	Unimax Switch, Div. of W. L. Maxson Corp.	Wallingford, Conn.	91921	Minneapolis-Honeywell Regulator Co., Micro-Switch Division	Freeport, Ill.	0000 U	Tower Mfg. Corp.	Providence, R.I.
80248	Oxford Electric Corp.	Chicago, Ill.	92196	Universal Metal Products, Inc.	Bassett Puente Calif.	0000 W	Webster Electronics Co. Inc.	New York, N.Y.
80294	Bourns Laboratories, Inc.	Riverside, Calif.	93332	Sylvania Electric Prod. Inc., Semiconductor Div.	Woburn, Mass.	0000 X	Spruce Pine Mica Co.	Spruce Pine, N.C.
80411	Acro Div. of Robertshaw Fulton Controls Co.	Columbus 16, Ohio	93369	Robbins and Myers, Inc.	New York, N.Y.	0000 Y	Midland Mfg. Co. Inc.	Kansas City, Kans.
80486	All Star Products Inc.	Defiance, Ohio	93410	Stevens Mfg. Co., Inc.	Mansfield, Ohio	0000 Z	Willow Leather Products Corp.	Newark, N.J.
80583	Hammerlund Co., Inc.	New York, N.Y.	93983	Insuline-Van Norman Ind., Inc. Electronic Division	Manchester, N.H.	000 A A	British Radio Electronics Ltd.	Washington, D.C.
80640	Stevens, Arnold, Co., Inc.	Boston, Mass.	94144	Raytheon Mfg. Co., Industrial Components Div., Receiving Tube Operation	Quincy, Mass.	000 B B	Precision Instrument Components Co.	Van Nuys, Calif.
81030	International Instruments, Inc.	New Haven, Conn.	94145	Raytheon Mfg. Co., Semiconductor Div., California Street Plant	Newton, Mass.	000 C C	Computer Diode Corp.	Lodi, N.J.
81312	Winchester Electronics Co., Inc.	Norwalk, Conn.	94148	Scientific Radio Products, Inc.	Loveland, Colo.	000 E E	A. Williams Manufacturing Co.	San Jose, Calif.
81415	Wilkor Products, Inc.	Cleveland, Ohio	94154	Tung-Sol Electric, Inc.	Newark, N.J.	000 F F	Carmichael Corrugated Specialties	Richmond, Calif.
81453	Raytheon Mfg. Co., Industrial Components Div., Industr. Tube Operations	Newton, Mass.	94197	Curtiss-Wright Corp., Electronics Div.	East Paterson, N.J.	000 G G	Goshen Die Cutting Service	Goshen, Ind.
81483	International Rectifier Corp.	El Segundo, Calif.	94310	Tru Ohm Prod. Div. of Model Engineering and Mfg. Co.	Chicago, Ill.	000 H H	Rubbercraft Corp.	Torrance, Calif.
81860	Barry Controls, Inc.	Watertown, Mass.	94682	Worcester Pressed Aluminum Corp.	Worcester, Mass.	000 I I	Birtcher Corporation, Industrial Division	Monterey Park, Calif.
82042	Carter Parts Co.	Skokie, Ill.	95236	Allies Products Corp.	Miami, Fla.	000 K K	Amatom	New Rochelle, N.Y.
82142	Jeffers Electronics Division of Speer Carbon Co.	Du Bois, Pa.	95238	Continental Connector Corp.	Woodside, N.Y.	000 L L	Avery Label	Monrovia, Calif.
82170	Allen B. DuMont Labs., Inc.	Clifton, N.J.				000 M M	Rubber Eng. & Development	Hayward, Calif.
82209	Maguire Industries, Inc.	Greenwich, Conn.						
82219	Sylvania Electric Prod. Inc., Electronic Tube Div.	Emporium, Pa.						
82376	Astron Co.	East Newark, N.J.						
82389	Switchcraft, Inc.	Chicago, Ill.						

THE FOLLOWING H-P VENDORS HAVE NO NUMBER ASSIGNED IN THE LATEST SUPPLEMENT TO THE FEDERAL SUPPLY CODE FOR MANUFACTURERS HANDBOOK.

0000 F	Malco Tool and Die	Los Angeles, Calif.
0000 I	Telefunken (c/o American Elite)	New York, N.Y.
0000 M	Western Coil Div. of Automatic Ind., Inc.	Redwood City, Calif.
0000 N	Nahm-Bros. Spring Co.	San Leandro, Calif.
0000 P	Ty-Car Mfg. Co., Inc.	Holliston, Mass.
0000 T	Texas Instruments, Inc. Metals and Controls Div.	Versailles, Ky.
0000 U	Tower Mfg. Corp.	Providence, R.I.
0000 W	Webster Electronics Co. Inc.	New York, N.Y.
0000 X	Spruce Pine Mica Co.	Spruce Pine, N.C.
0000 Y	Midland Mfg. Co. Inc.	Kansas City, Kans.
0000 Z	Willow Leather Products Corp.	Newark, N.J.
000 A A	British Radio Electronics Ltd.	Washington, D.C.
000 B B	Precision Instrument Components Co.	Van Nuys, Calif.
000 C C	Computer Diode Corp.	Lodi, N.J.
000 E E	A. Williams Manufacturing Co.	San Jose, Calif.
000 F F	Carmichael Corrugated Specialties	Richmond, Calif.
000 G G	Goshen Die Cutting Service	Goshen, Ind.
000 H H	Rubbercraft Corp.	Torrance, Calif.
000 I I	Birtcher Corporation, Industrial Division	Monterey Park, Calif.
000 K K	Amatom	New Rochelle, N.Y.
000 L L	Avery Label	Monrovia, Calif.
000 M M	Rubber Eng. & Development	Hayward, Calif.

00C15-23
Revised: 30 March 1962

From: F.S.C. Handbook Supplements
H4-1 Dated February 1962
H4-2 Dated January 1962

WARRANTY CLAIM AND ADJUSTMENT PROCEDURE

for microwave tubes supplied by the
HEWLETT-PACKARD COMPANY
for use in Hewlett-Packard instruments

The procedure described below is for use within the United States. For warranty claims arising outside the U.S.A., before returning the tube, fill out the form on the reverse side and send it with a request for shipping instructions to your nearest Hewlett-Packard Sales and Service Office or to:

(in Western Europe)

Hewlett-Packard S.A.
1217 Meyrin
Geneva, Switzerland
Telephone: (022) 41 54 00
Telex: 2.24.86
Cable: HEWPACKSA
Cable: HEWPACK

(Rest of World)

Hewlett-Packard Co.
International Marketing Dept.
1501 Page Mill Road
Palo Alto, California, 94304, U.S.A.
Telephone: (415) 326-7000
Telex: 033811

Microwave tubes supplied by the Hewlett-Packard Company, either as original or replacement, for use in Hewlett-Packard instruments are actually warranted by the tube manufacturer and not by Hewlett-Packard. However, all warranty claims on tubes obtained from us either as original or replacement will be processed by Hewlett-Packard.

In the event of failure you should purchase a new tube and return your old tube immediately to Hewlett-Packard. Credit allowances will be passed on to you upon receipt of the defective tube.

For your convenience, warranty claims for all microwave tubes supplied by the Hewlett-Packard Company may be made on this single form; merely fill out the information on the reverse side and return this form, along with the defective tube, to your Hewlett-Packard Sales and Service Office or to Hewlett-Packard. Please be sure each space on the form is filled in--lack of complete information may delay processing of your claim. Each tube manufacturer has his own warranty policy. Copies of individual Conditions of Warranty are available from your Hewlett-Packard Sales and Service Office or from the Hewlett-Packard Company.

SHIPPING INSTRUCTIONS

The following instructions are included to aid you in preventing damage in transit. Package your tube carefully-- no allowance can be made on broken tubes.

1. Carefully wrap tube in 1/4-inch thick cellulosic cushioning, cotton batting, or other soft padding material. Cable assemblies and other accessories not rigidly mounted to the tube should be padded and wrapped separately to prevent damage to the tube during shipment.
2. Wrap the above in heavy kraft paper.
3. Pack in a rigid container which is at least 4 inches larger than the tube in each dimension.
4. Surround the tube with at least 2 inches of shock absorbing material. Be certain that the packing is tight all around the tube.
5. Tubes returned from outside the continental United States should be packed in a wooden box.
6. Mark container FRAGILE and ship prepaid via Air freight or Railway Express. Do not ship via Parcel Post or Air Parcel Post since experience has shown that fragile items are more apt to be damaged when shipped by these means.

Note

Tubes with permanent magnets can interfere with magnetic compasses. For air shipment plainly mark container: "MAGNETIZED MATERIAL"

In warranty tubes purchased from Hewlett-Packard may be returned, with a completed warranty Claim Form, to your local Hewlett-Packard Sales and Service Office, or to:

Hewlett-Packard Company
Customer Service Center
333 Logue Avenue
Mountain View, California 94040
USA

Rev 12/16/69

MICROWAVE TUBE WARRANTY CLAIM
INFORMATION FORM

IMPORTANT: Please answer all questions fully -- insufficient information may delay processing of your claim.

DATE: _____

FROM: (Tube Owner)

Company _____

Address _____

Tube type _____

Tube serial No. _____

Tube mfr. _____

Use in HP Model _____

Instrument serial No. _____

Tube is Original () or Replacement ()

Date tube received _____

Date of failure _____

Total hours filament operation _____

SYMPTOMS: (Please describe conditions prior to and at time of failure, along with description of tube's defect, if known) _____

IMPORTANT:
Replacement (new) tube serial No. _____

Signature _____

Title _____

For HP use only
Repair order # _____

**APPENDIX G
BACKDATING
MODEL 626A**

Serial Prefix	Make Changes	Serial Prefix	Make Changes
Serials 176 & below	A thru Q	019-	E thru Q
Serials 201 & below	B thru Q	134-	F thru Q
Serials 261 & below	C thru Q	229-	G thru Q
003-	D thru Q	250-	H thru Q

Serial Prefix	Make Changes	Serial Prefix	Make Changes
609-	I thru Q	976-01461 to 976-01470	M thru Q
651-	J thru Q	976-01471 to 976-01480	N thru Q
651-01561 to 651-01400	K thru Q	976-01481 to 976-01520	O, P, Q
651-01401 to 651-01460	L thru Q	1101A	P, Q
		1202A	Q

CHANGE A

Change paragraph 2-2, page 2-1, to read as follows:

Normally, the Model 626A is shipped from the factory with the power transformers (T1 and T2) wired for 115V 50/60 cycle power line operation. The instrument may be easily converted, however, to operate from a 230V 50/60 cycle power line source by changing the wiring of the primary windings from a parallel to a series arrangement, as shown in the schematic. The conversion procedure is as follows:

1. On T1 and T2, remove the bare wire jumpers between terminals 2A and 5A, and terminals 1A and 4A.
2. Connect new jumpers between terminals 4A and 5A, on T1 and T2.
3. Replace the 2. 5-ampere Slo-Blo line fuse for use with 115-volt power with a 1. 25-ampere Slo-Blo fuse.

Change R74 from 18, 000 ohms to: resistor, fixed, composition, 12, 000 ohms, ±10%, 2 W; -hp- Stock No. 25-23K; Mfr., B, HB 1231.

Change R74 on the schematic to read 12K.

CHANGE B

Page 2 make the following changes:

- V17 heater wire to FL3 should be yellow
- V17 heater-cathode wire to FL4 should be white

Change Modulator and RF Generator Schematic as follows:

Voltage on P7 pin 3 should be -650V

Add the following information on page 4-11 an paragraph 4-9:

-CAUTION-

Before removing the klystron, of the klystron cavity and frequency drive mechanism, you must withdraw the PWR. SET, attenuator from the klystron cavity. Failure to do this will result in a broken power set attenuator. The following steps should be followed to protect the power set attenuator when changing the klystron:

Model 626A

CHANGE B Continued

1. Rotate the PWR. SET control maximum clockwise.
2. In Figure 4-8, locate the POWER SET ATTEN. DRIVE in the upper left hand corner of the picture. Loosen the Allen set screws that hold the large gear in the attenuator drive.
3. Locate the collar on the attenuator drive shaft (parallel with the panel) and gently pull this collar away from the large attenuator drive gear until it stops. The power set attenuator card will now be clear of the klystron cavity and you may proceed with the klystron removal.
4. After the klystron assembly has been installed, slide the attenuator shaft back toward the large drive gear making sure the set screw on the collar is on top.
5. With the PWR. SET knob maximum clockwise, press the large gear and collar together with your fingers and tighten the set screws on the gear.
6. Check the operation of the PWR. SET control to make sure it operates smoothly.

CHANGE C

Parts List:

- Change S1 to switch, toggle HP 310-11.
- Change R117 to resistor, fixed 750K +1%, HP 33-750K.
- Change R118 to resistor, fixed 284K \pm 1%. HP 33-284K.
- Change R121 to resistor, fixed 900K, \pm +1, HP 31-900K.
- Change R122 to resistor, fixed 405K, +1%, HP 33-450K.
- Under miscellaneous change fuseholder to HP 140-16.

CHANGE D

Parts List:

- Delete CR2 through CR15.
- Delete C46 A/B and C47A/B.
- Delete R142.
- Delete R132 through R239.
- Delete R140 and R141.
- Delete RT1, ballast tube.
- Change T1 to HP 910-141.
- Change T2 to HP 910-140.
- Add C2, C3, C13 and C14; capacitor fixed electrolytic, 45 if., 450 v.d.c.w.
- Add SR1 and SR2; Rectifier, metallic HP 212-110.
- Add SR3; Rectifier, metallic HP 212-111.
- Add SR4; Rectifier, metallic HP 212-111.
- Add SR5; Rectifier, metallic HP 212-113.

CHANGE E

Parts List:

- Delete C48.
- Change R115 to HP 210-211.
- Miscellaneous: Mechanical modification in the RF Output connector changes the appearance of the front panel from that shown in the manual. The plastic cover is replaced by a metal captive cap for the flange.

Model 626A

CHANGE F

Figure 5-18:

Change connection on T1 from C3 to C2.

Figure 5-18 and Parts List:

Change R15 to HP 0730-0100, 800K ohms, i1%, 1W.

Change R30 to HP 0727-0244, 516K ohms, +1%, 1/2W.

Figure 5-20 and Parts List:

Change R41 to HP 0773-0009, 66K ohms, +5%, 5W.

Change R52 and R53 to HP 0730-0079, 216.3K ohms, i1%, 1W.

Change R64 to HP 0773-0009 66K ohms, i5%, 5W.

Change R65 to HP 0690-4751, 4.7 Megohm.

Change R79 to HP 0687-4741, 33K ohms, +10%, 1/2W.

Figure 5-22 and Parts List:

Delete R91

Parts List:

Change L3 and L6 to 200ijH, same part number.

Change RT123 to HP 0839-0005 thermistor, WE 170575.

Table 6-2:

Delete reference to HP Part No. 626A-38B.

Add Screwdriver, HP Part No. 626A-38B-1, and Wrench Assembly Tube, HP Part No. 626A-38B-2.

Change HP Part No. 626A-650D to 626A-65A.

Change HP Part No. 626A-65E to 626A-65B.

Change HP Part No. 626A-65F to 626A-65C.

CHANGE G

Figure 5-22 and Parts List:

Change C40 to HP 0150-0012, 0. 01f ±20% 1000 v. d. c. w.

CHANGE H

Table 1-1, Under "Output Range".

Change to read, "- - - SWR less than 2. 5 at +IOdBm; 1.2 at OdBm and lower".

CHANGE I

Figure 5-20 and Parts List:

Delete the asterisk (*) adjacent to R41. This was not a factory selected value.

CHANGE J

Parts List:

Change B1 fan motor to HP 3140-0010.

CHANGE K

Figure 5-18 and Parts List:

Change R131 * to HP 0693-6801, 68* ohms, +10%, 2W.

CHANGE L

Page 2-1, paragraph 2-11:

Delete paragraph 2-12 and replace with the following:

2-12. To operate the Model 626A from a 230-volt +10% source, change the primary windings of T1 and T2 from a parallel to a series arrangement. Refer to the schematic diagram and proceed as follows:

- a. Remove the two bare wire jumpers from the terminals on T1 and T2. These jumpers connect terminal A1 to A4 and A2 to A5 on the primary winding.
- b. Connect a new jumper between terminal A4 and A5.
- c. Change the line fuse to a 1.25 amp slow-blow.

CHANGE L Continued

Page 5-23, Figure 5-18:

Replace existing figure 5-18 with figure 5-18 below:

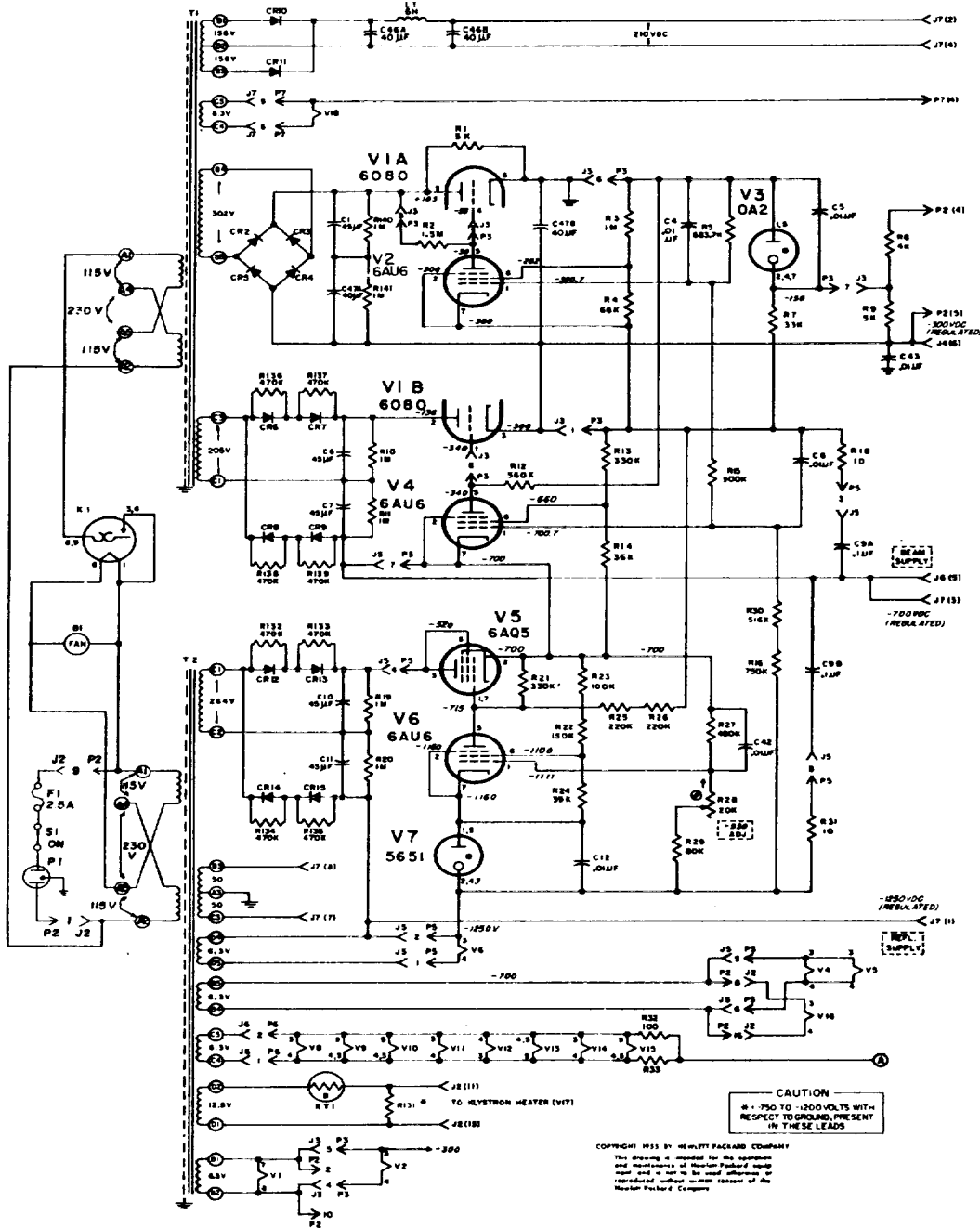

Model 626A

CHANGE L Continued

Parts List:

Delete DS1, glow lamp, HP Part No. 2140-0244.
Add I1, Lamp, incd: 6-8v. type 47, HP 2140-0009.
Delete J1 connector: AC receptacle, 3 pin male, HP Part No. 1251-2357.
Delete R142, R: Fxd, met. flm., 34. 8K ohm, 1%, 1/2W, HP Part No. 9757-0123.
Delete S5, switch: slide 4PDT, HP Part No. 3101-1272.
Change P1, Power Cable to HP 8120-0015. The power cord is not detachable.
Change S1, Push-button switch to HP 3101-0030. Switch, toggle SPST

CHANGE M

Page 6-8, Table 6-1:

Change V11 HP Stock No. and Description to 1941-0003 Tube, electron: 5696.

Page 6-7, Table 6-1:

Delete R126, R127, the HP Stock No. and Description.

Page 6-5, Table 6-1:

Change R54 HP Stock No. and Description to 0687-4731 R: Fxd. comp. 47K ohm 10%, 1/2W.

Page 6-2, Table 6-1:

Change C26 and C30 HP Stock No. and Description to 0140-0003 C: Fxd. Mica 100Opf 10%, 500 udc W.

Page 5-25, Figure 5-20:

Change V11 description to 5696.
Delete R126, R127.
Change R54 description to 47K.
Change C26 and C30 description to 100Opf.

CHANGE N

Page 6-8, Table 6-1:

Change V14 HP Stock No. and Description to 1941-0003 tube, electron: 5696.

Page 6-7, Table 6-1:

Add R126, 127 0687-3951 R: Fxd., comp. 3.9M i10%, 1/2W.

Page 6-5, Table 6-1:

Change R54 HP Stock No. and Description to 0687-1051 R: Fxd., comp. 1 MEG ohm, 10%, 1/2W.

Page 6-5, Table 6-1:

Add R59 & R67 HP Stock No. and Description 0687-1041 R: Fxd. comp.
100K ohm 10%, 1/2W.

Page 5-25, Figure 5-20:

Change V14 description to 5696.
Show R127 3. 9M resistor connected between V14 pins 5, 7 and the junction of R63 and C48.
Show R126 3. 9M resistor connected between V11 pin 5, 7 and the junction of R57 and R60.
Change R54 description to 1M.
Show R59 100K resistor connected between the -300V buss line and V11 pins 5, 7.
Show R67 100K resistor connected between the -300V buss line and V14 pins 5, 7.
Show no connection from V14 pin 2 and pin 5, 7
Show no connection from V11 pin 2 and pin 5, 7

CHANGE O

Change all references in manual, pertaining to Sync Out Pulse Delay, from "5 to 300 microseconds" to "3 to 300 microseconds".

Table 1-1, Sync Out Signal, change to read, "- - - variable 3 to 300 microseconds".

CHANGE P

Parts List and Illustrated Parts Identification:

These instruments manufactured with Blue-Gray Panel and Cabinet parts only.

CHANGE Q

Parts List

Change C35 from HP 0160-3192, 0. 11f. 1200v., to HP 0160-0050, 0. μ f, 400v.

MANUAL IDENTIFICATION

Model Number: 626A
 Date Printed: March, 1972
 Part Number: 00626-90005

This supplement contains important information for correcting manual errors and for adapting the manual to instruments containing improvements made after the printing of the manual.

To use this supplement:

- Make all ERRATA corrections
- Make all appropriate serial number related changes indicated in the tables below.

Serial Prefix or Number	Make Manual Changes	Serial Prefix or Number	Make Manual Changes
1210A01731 to			
01800	1	1410A	1-4
1308A01801 to 01850	1, 2	1542A	1-5
1308A01851 to 01920	1-3	▶ 1607A	1-

▶ NEW ITEM

ERRATA

Page 5-19, paragraph 5-57:
 In step d, change "< 3 microseconds" to "< 5 microseconds".

▶ Page 5-23, Figure 5-18:
 Delete C43.

Page 5-25, Figure 5-20:
 Change R54 to 47K and R58 to 100K.
 Delete R127. Page 6-3, Table 6-1:

▶ Page 6-8, Table 6-1:
 Delete C43.

▶ Page 6-13, Table 6-1:
 Change HP stock number for V9 and V10 to 1932-0027.

▶ Page 6-13, Table 6-2:
 Change 3101-0030 to 3101-1248 Switch, Push-button.

NOTE

Manual change supplements are revised as often as necessary to keep manuals u current and accurate as possible. Hewlett-Packard recommends that you periodically request the latest edition of this supplement. Free copies are available from all HP offices. When requesting copies quote the manual identification information from your supplement, or the model number and print date from the title page of the manual

Model 626A

ERRATA (Contd.)

Page 6-14, Table 6-2:

▶ Change 626A-95A to 00626-6003.

Delete 1400-0084 Fuseholder, and add the following Items In its place.

1400-0090	Washer, neoprene
2110-0465	Cap, fuseholder
2110-0467	Nut, hex
2110-0470	Fluseholder

NOTE

If any part of the old fuseholder (1400-0084) needs replacing all four parts of the new fuseholder must be ordered. The old fuseholder can be identified by a straight solder lug to which the white-black-gray wire attaches. On the new fuseholder the solder lug is at a right angle to the body.

Add 7120-4162 Label, warning, large (3 each) "HAZARDOUS VOLTAGE" (Large).

Add 7120-4163 Label, warning, small (2 each) "HAZARDOUS VOLTAGE" (Small).

Add 7120-4295 Label, warning "HAZARDOUS VOLTAGE ALWAYS PRESENT...."

Add 7120-5087 Label, warning "TO PREVENT ELECTRICAL SHOCK"

Illustrated Parts Identification, page 15:

Change item 1 to 2680-0129 Screw, Machine 10-32 0.312 Inch long, pan head, Pozidriv.

Change item 2 to 2680-0211 Screw, Machine 10-32 0.312 inch long, Flat head, Pozidriv.

CHANGE 1

Page 4-3, Figure 4-5:

Change R43 to 1.23M.

Page 5-25, Figure 5-20:

Change R43 to 1.23M.

Page 6-5, Table 6-1:

Change R43 to 0730-0108 R:FXD, DEP C, 1.23M 1% 1W, 28480, 0730-0108.

Page 6-11, Table 6-2:

Delete 0730-0110.

Add 0730-0108 R:FXD, DEP C, 1.23M 1% 1W, 28480, 0730-0108.

CHANGE 2

Page 6-2, Table 6-1:

Change C36 to 0160-0595, C: FXD PAPER 0.25 UF $\pm 10\%$ 1500 VDCW.

Page 6-3, Table 6-1:

Change C39 to 0160-0593, C:FXD PAPER, 1UF $\pm 10\%$ 600 VDCW.

Page 6-9, Table 6-2:

Delete 0160-0079 and 0160-0088.

Add:

0160-0593, C:FXD PAPER 1 UF $\pm 10\%$ 600 VDCW, 56289, P34315.

0160-0595, C:FXD PAPER 0.25 UF: 10% 1500 VDCW, 56289, P52789.

NOTES

1. When 0160-0593 first replaces 0160-0079, a new mounting bracket, HP Part Number 1400-0512, must also be ordered
2. When 0160-0595 first replaces 0160-0088, a new mounting bracket, HP Part Number 1400-0525 must also be ordered

Model 626A

CHANGE 3

Page 4-5, Figure 4-9:
Change R69 to 75K

Page 5-25, Figure 5-20:
Change R69 to 75K.

Page 6-5, Table 6-1:
Change R69 to 0686-7535, R:FXD COMP 75K OHM 5% 1/2W.

Page 6-9, Table 6-2:
Add 0686-7535, R:FXD COMP 75K OHM 5% 1/2W, 01121, EB 7525, 1, 1.

Page 6-10, Table 6-2:
Delete 0687-5631.

CHANGE 4

Page 4-9, Figure 4-15:
Change R98 to 2500 ohms.

Page 5-27, Figure 5-22:
Change R98 to 2500 ohms.

Page 6-6, Table 6-1:
Change R98 to 2100-0207, R: VAR, CONT, 2.5K OHM 20% MC.

Page 6-12, Table 6-2:
Delete 2100-0025.
Add 2100-0207, R: VAR, CONT, 2.6K OHM, 20% MC.

CHANGE 5

Page 5-23, Figure 5-18:
Change line switch as shown in the following Illustration.

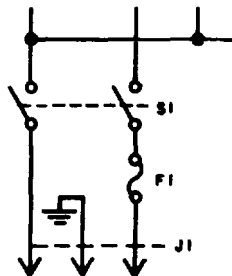

Page 6-7, Table 6-1:
Change S1 to 3101-1395 SWITCH-PB DPDT-DB ALTNG 10.5A 250 VAC

Page 6-13, Table 6-2:
Change 3101-1248 (see Errata) to 3101-1395 SWITCH-PB DPDT-DB ALTO

CHANGE 6

Page 5-25, Figure 5-20:

Change C25 to 100pF.

Change R54 to 100kL.

Change t58 to 47k'1.

Page 6-2, Table 6-1:

Change C25 to 0140-0041 C: fxd, mica 100pF 5% 500 wvdc.

Page 6-5, Table 6-1:

Change R54 to 0687-1041 R: fxd comp 100k ohm 10% 1/2w.

Change R58 to 0687-4731 R: fxd comp 47k ohm 10% 1/2w.

ILLUSTRATED PARTS IDENTIFICATION

MODEL 626A

**SUPER HIGH FREQUENCY
SIGNAL GENERATOR**

Copyright HEWLETT-PACKARD COMPANY 1965
1501 PAGE MILL ROAD. PALO ALTO, CALIFORNIA, U.S.A.

PRINTED: JAN 1965

REF.	STOCK NO.	DESCRIPTION	QTY.
1		See Figures 8 and 9	
2		See Figure 5	
3		See Figure 8	
4		See Figure 8	
5		See Figure 4	
6		See Figure 6	
7		See Figures 2 and 3	
8		See Figure 7	
9		See Figure 10	

REF.	STOCK NO.	DESCRIPTION	QTY.
------	-----------	-------------	------

REF.	STOCK NO.	DESCRIPTION	QTY.
------	-----------	-------------	------

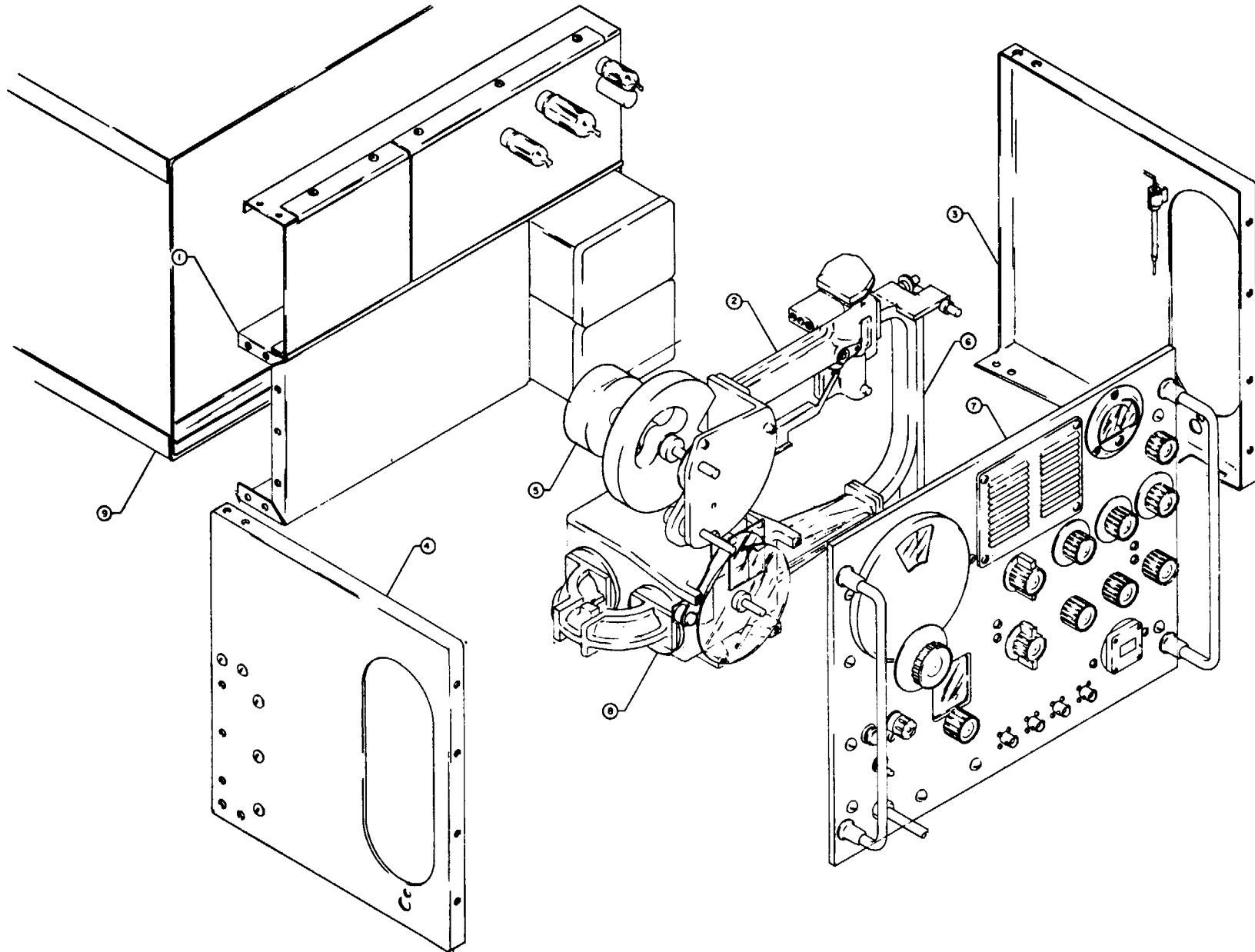

Figure 1. -hp-Model 626A, S.H.F. Signal Generator, General Arrangement

REF.	STOCK NO.	DESCRIPTION	QTY.
1	628A-2	Panel: Cabinet Model	1
2	2190-0034	Washer: Split lock for #10 screw	4
3	2990-0002	Screw: Truss head ss 10-24 thd 3/8 in. lg	19
4	2950-0038	Nut: 11/16 in. wide 1/2-24 thd	1
5	2190-0037	Washer: Int. lock 0.78 o.d.	1
6	3101-0030	Switch: Toggle s.p.s.t.	1
7	2950-0035	Nut: 9/16 in. wide 15/32-thd	1
8	0590-0037	Nut: 13/16 in. wide 11/16-27 thd	1
9	2190-0002	Washer: Int. lock 61/64 in. o.d.	1
10	J382A-17	Mount: Gear	1
11	3030-001	Screw: Allen dr set 8-32 thd 3/16 in. lg	26
12	61B-3AT	Ferrule, Panel handle	4
13	0525-0002	Screw: Round head ss 3-56 thd 3/8 in. lg	16
14	0900-0016	O-Ring: 1/2 in. i.d.	1
15	0590-0012	Nut: .60 in. Dia 15/32-32 thd	1

REF.	STOCK NO.	DESCRIPTION	QTY.
16	2390-0001	Screw: Bind head ss 6-32 thd 1/2 in. lg	1
17	3050-0032	Washer: 3/8 in. o.d. 0.172 in. o.d.	1
18	5000-0202	Dial: Blank 1-3/4 in. dia	3
19	618B-3E	Handle: Panel	2
20	0400-0004	Grommet: Nylon	1
21	8120-0015	Cable: R. F. R-G. -58U per ft	1
22	1400-0084	Fuseholder: Post type 2-5/64 in. lg	1
23	2110-0015	Fuse: Cartridge 2.5 amp 125 volt	1
24	1450-0004	Light: Red indicator 1/2 in. dia	1
25	2140-0009	Lamp: Incandescent clear no. 47 6-8v	1
26	0370-0029	Knob: 1 in. dia, blk 1/4 in. shaft with arrow	3
27	3050-0117	Washer: 1 in o.d. 5/16 in. i.d.	1
28	61B-40D-3	Hub: Frequency dial	1
29	61B-40D-4	Plate: Frequency dial	1
30	2370-0001	Screw: Flat head ss 6-32 thd 1/4 in. lg	4
31	620A-40B	Window: dial	1

REF.	STOCK NO.	DESCRIPTION	QTY.
32	628A-36A-9	Dial: Frequency	1
33	2190-0016	Washer: Int lock 1/2 in. o.d.	8
34	2950-0001	Nut: 1/2 in. wide 3/8-32 thd	8
35	0370-0030	Knob: 1 in. dia, blk 1/4 in. shaft	3
36	628A-3C	Bezel: Air filter	1
37	1120-0037	Meter: 200A dbm	1
38	2280-0005	Screw: Round head br 4-40 thd 5/8 in. lg	3
39	628A-41A	Plate: Panel	1
40	2470-0001	Screw: Bind head br 6-32 thd 1/4 in. lg	4
41	2550-0009	Screw: Bind head ss 8-32 thd 1/2 in. lg	6
42	61B-40D-2	Cover: Freq. dial	1
43	628A-40A	Dial: Vernier	1
44	2200-0010	Screw: Round head ss 4-40 thd 3/4 in. lg.	4
45	0520-0025	Screw: Round head 2-56 thd 1/8 in. lg	3
46	0370-0035	Knob: 3/4 in. Dia, blk 1/4 in. Shaft	2
47	0370-0028	Knob: 1 in. dia, blk 1/4 in. shaft	2

General Arrangement

TM 11-6625-2910-14
Model 626A

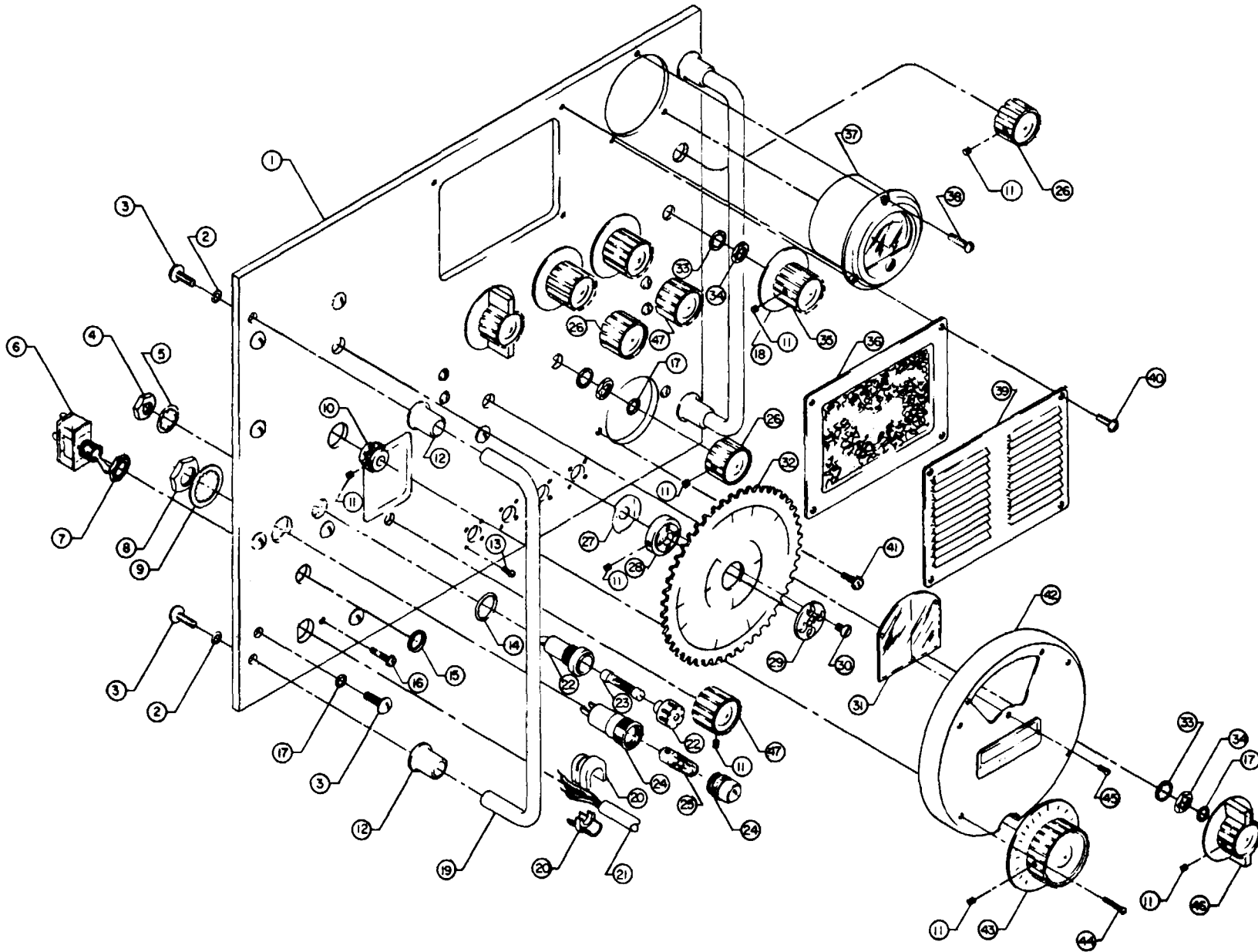

Figure 2. -hp- Model 626A, S. H. F. Signal Generator, Control Panel, Front View

REF.	STOCK NO.	DESCRIPTION	QTY.
1	00626-60018	Panel: Cabinet Model	1
	00626-60019	Panel: Rack Model	
2	2190-0016	Washer: Int. lock 1/2 in. o.d.	15
3		See Operating and Service Manual	
4	1410-0003	Bushing: Threaded 3/8-32 thd 1/2in lg	4
5	5000-0206	Washer: Spring 9/16 in. dia	4
6	5020-0233	Collar: 1/4 in. shaft 1/2 in. dia	3
7	3030-0001	Screw: Allen dr set 8-32 thd 3/16 in. 0g	14
8	2360-0002	Screw: Round head ss 6-32 thd 1/4 in. 4;	1
9	1500-0002	Yoke: Coupler 1/4in.	
10	1360-0011	Strip: 1 Terminal	1
11	5020-0319	Shaft: 1/4 in. dia 1-3/16 in. lg	1
12	2360-0007	Screw: Phillips ss 6-32 thd 1/2 in. lg	2
13	628A-41B	Insulator: Modulator	1
14	2360-0005	Screw: Round head ss 632 thd 3/8in. lg	13
15	21900-0007	Washer: Int. lock for #6 screw	6
16	2190-0018	Washer: Split lock for #6 screw	9
17		See Operating and Service Manual	

REF.	STOCK NO.	DESCRIPTION	QTY.
18	1200-0053	Socket: 7 Pin tube printed circuit mtg	1
19	1200-0059	Socket: 9 Pin tube shield base printed circuit mtg	1
20	2950-0033	Nut: 1/2 in. wide 3/8-32 thd	7
21	2950-0001	Nut: 1/2 in. wide 3/8-32 thd	11
22	628A-65C	Board: Modulator	1
23	5020-0238	Head: Coupler 3/4 in. dia	1
24	3050-0080	Washer: Bakelite 1/4 in. dia	1
25	5020-0341	Shaft: 1/4 in. ss 1-5/8 in. lg	1
26	5040-0212	Insulator: Coupler 1 in. dia	3
27		See Operating and Service Manual	
28	2550-0009	Screw: Bind head ss 8-32 thd 1/2 in. lg	1
29	0590-0035	Nut: For locking bushing	2
30	0590-0036	Bushing: Locking	1
31	1210-0006	Bracket: Capacitor mtg	2
32	628A-41C	Board: Pot mtg	1
33	2200-0005	Screw: Round head ss 4-40 thd 5/16 in. lg	4
34	2190-0004	Washer: Int lock for #4 screw	4
35	2390-0009	Screw: Bind head ss 6-32 thd 3/8 in. lg	2

REF.	STOCK NO.	DESCRIPTION	QTY.
36	628A-12C	Bracket Right	1
37	2190-0005	Washer: Ext lock for #4 screw	8
38	2260-0001	Nut: 1/4 in. wide 4-40 thd ss	8
39	2420-0003	Nut: 1/4 in. wide 6-32 thd ss	4
40	2190-0008	Washer: Ext lock for #6 screw	2
41	0360-0016	Lug: Terminal 3/4 in. lg	
42	2550-0007	Screw: Bind head ss 8-32 thd 3/8 in. lg	3
43		See Operating and Service Manual	
44	628A-12D	Bracket Right	1
45	2190-0009	Washer: Int. lock for #8 screw	2
46	0360-0005	Lug: Terminal 11/16 in. lg	1
47	628A-41D	Insulator: Capacitor	1
48		See Operating and Service Manual	
49		See Operating and Service Manual	
50		See Operating and Service Manual	
51	1210-0003	Bracket: Capacitor mtg	1
52	2200-0008	Screw: Round head ss 4-40 thd 7/16 in. lg	4
53	628A-65C-2	Board: Thermistor	1

Control Panel, Rear View

TM 11-6625-2910-14
Model 626A

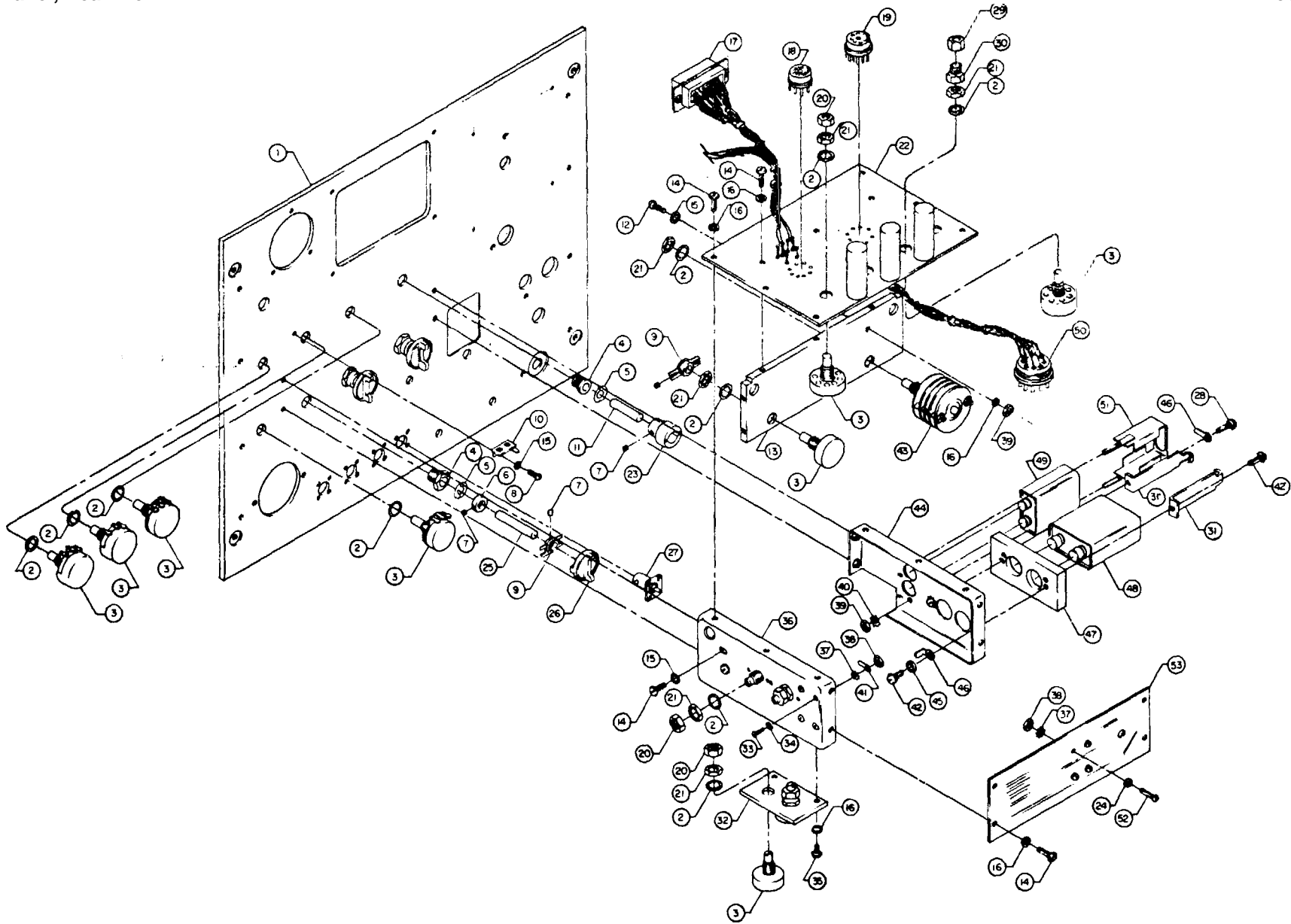

Figure 3. -hp- Model A, S.H.F. Signal Generator, control Panel, Rear view

REF.	STOCK NO.	DESCRIPTION	QTY.
1	2360-0018	Screw: Round head ss 6-32 thd 1-3/8 in. Lg	1
2		See Operating and Service Manual	
3	3030-0005	Screw: Allen dr set 8-32 thd 1/8 in. lg	5
4	2190-0007	Washer: Int lock for # 6 screw	3
5	0380-0014	Spacer: 1-3/16 in. Lg ¼ in. o.d.	1
6	3030-0001	Screw: Allen dr set 8-32 thd 3/16 in. lg	7
7	628A-36A- 22	Drive: Coupling	1
8	628A-36A- 5	Cam: Microswitch	1
9	5020-0389	Washer: Spring	3
10	628A-36A- 13	Hub: Cam	1
11	2360-0016	Screw: Round head ss 6-32 the 1-1/4 in. lg	2
12	628A-36Q- 21	Washer	1
13	2420-0001	Nut; 5/16 in. wide ss 6-32 thd ½ in. lg	1
14	2990-0002	Screw: Truss head ss 10-24 thd ½ in. lg	1
15	2190-0011	Washer: Int lock for # 10 screw	1

REF.	STOCK NO.	DESCRIPTION	QTY.
16	1410-0017	Bearing: Ball	2
17	3050-0019	Washer: ½ in. o.d.	1
18	5020-0248	Gear: Offset tooth	1
19	3102-0002	Lever: Switch actuator	1
20	628A-36A- 30	Shaft	1
21	628A-36A- 23	Cam: Drive	1
22	J382A-17	Mount: Gear	1
23	3050-0032	Washer: 5/16 in. o.d. 0.190 in. i.d. brass	11
24	1410-0007	Bearing: Ball ½ in. o.d. 3/16 in. i.d.	2
25	0570-0022	Screw: 3/8 in. lg	1
26	3030-0033	Screw: Allen dr set 6-32 thd 3/165 in. lg	2
27	628A-36A- 6	Gear: Stop	1
28	628A-36A- 28	Sleeve	1
29	0380-0018	Spacer: ¼ in. lg ¼ in. o.d.	2
30	628A-36A- 27	Eccentric	1
31	628A-36A- 1	Chassis	1
32	628A-36A- 29	Clamp	1
33	628A-36A- 13	Hub: Cam	1

REF.	STOCK NO.	DESCRIPTION	QTY.
34	3050-0014	Washer: 3/8 in. o.d. 0.26 in. i.d. bronze	1
35	626A-77A- 2	Follower: Cam	1
36	1460-0022	Spring: Tension 1/8 o.d. 1-1/2 in. lg	2
37	0360-0036	Lug: Terminal	2
38	1410-0004	Bearing: Ball 5/8 in. o.d. ¼ in. i.d.	3
39	3050-0017	Washer: 3/8 in. o.d. 0.26 in. i.d. bronze	3
40	0510-0052	Ring: Grip for 1/8 in. shaft	1
41	2470-0001	Screw: Bind head br 6-32 thd ¼ in. lg	2
42	1410-0015	Bearing: Ball 5/8 in. o.d. ¼ in. i.d.	2
43	1480-0001	Pin: Cotter ½ in. lg	1
44	628A-36A- 14	Bushing: Eccentric	1
45	628A-36A- 14	Bracket: Cam follower	1
46	628A-36A- 14	Shaft: Cam	1
47	628A-36A- 14	Shaft: Cam roller	1
48	0510-0040	Ring: Grip for 5/16 in. shaft	1
49	628A-36A- 14	Shaft: Dial	1
50	0510-0005	Ring: Retaining for ¼ in. shaft	1

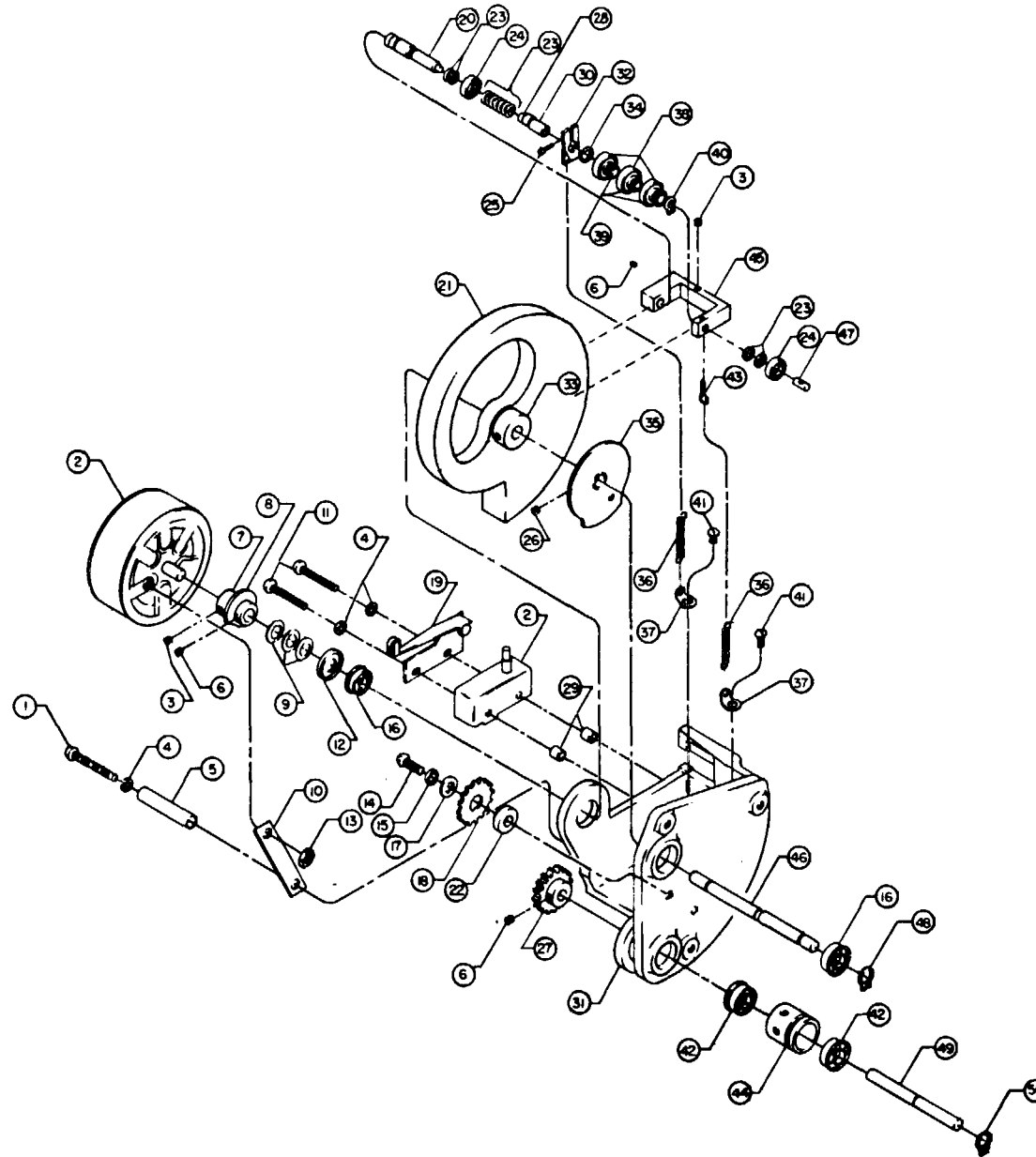

Figure 4. -hp- Model 626A, S. H. F. Signal Generator, Frequency Drive Assembly

REF.	STOCK NO.	DESCRIPTION	QTY.
1	2200-0010	Screw: Round head ss 4-40 thd ¾ in. lg	1
2	626A-77A- 2	Follower: Cam	1
3	626A-77A 4	Arm: Lever	1
4	0510-0005	Ring: Retaining for ¼ in. shaft	1
5	3050-0017	Washer: 3/8 in. o.d. 0.26 in. i.d. bronze	3
6	2260-0001	Nut: ¼ in. wide 4-40 thd ss	2
7	2190-0004	Washer: Int. Lock for #4 screw	2
8	626A-77A- 3	Nut: Elastic	1
9	2200-0004	Screw: 4-40 thd	2
10	0520-0001	Screw: 2-56 thd	4
11	0510-0011	Ring: Retaining	1
12	2210-0004	Screw: Flat head ss 4-40 thd ½ in. lg	1
13	626A-77A- 5	Hub: Lever arm	1
14	3030-0026	Screw: Cap	1
15	26A-77C-1	Holder: #2	1
16	628A-32A- 3	Load: Coupler	2

REF.	STOCK NO.	DESCRIPTION	QTY.
17	626A-37A	Shaft: Lever arm	1
18	626A-59A- 10	Plate: Bearing	1
19	3050-0014	Washer: 3/8 in. o.d. 0.26 in. i.d. bronze	2
20	3030-0001	Screw: Allen dr. Set 8-32 thd 3/16 in. lg	1
21	0570-0022	Screw: 1-72 thd	2
22	3050-0010	Washer: 5/16 in. o.d.	4
23	626A-77E- 2	Holder: Load	1
24	2200-0009	Screw: Round head ss 4-40 thd ½ in. lg	1
25	0510-0039	Ring: Retaining for ½. in hsg	1
26	3030-0033	Screw: Allen dr. Set 6-32 thd 3/16 in. lg	2
27	1460-0036	Spring: Compression 6 turns x 9/32 in. lg	1
28	626A-77A- 8	Spring: End plate	1
29	626A-59A- 9	Load: Plunger	1
30	626A-59A- 3	Plunger Assy	1
31	3030-0016	Screw: Allen dr cap 6-32 thd ½ in. lg	8

REF.	STOCK NO.	DESCRIPTION	QTY.
32	0570-0023	Screw: 0-80 thd	2
33	0590-0026	Nut: 3/32 in. wide 0-80 thd br	2
34	626A-77A- 7	Pin: Suppressor	1
35	626A-77A- 6	Pin: Guide	1
36	0570-0007	Screw: Fil head br 0-80 thd 3/16 in. lg	1
37	626A-77E- 1	Load: ¼ wave	1
38	626A-59A- 1	Casting	1
39	626A-59A- 2	Cap: Tube	1
40	3030-0003	Screw: Allen dr set cap 6-32 thd 3/8 in. lg	12
41	626A-77B- 2	Load: ¾ wave	1
42	626A-77B- 3	Holder: #1	1
43	3030-0028	Screw: Allen dr set cap 6-32 thd ¼ in. lg	1
44	3030-0030	Screw: Allen dr set cap 6-32 thd 1 in. lg	2
45	626A-77B- 1	Screw: Lock	1
46		See Operating and Service Manual	

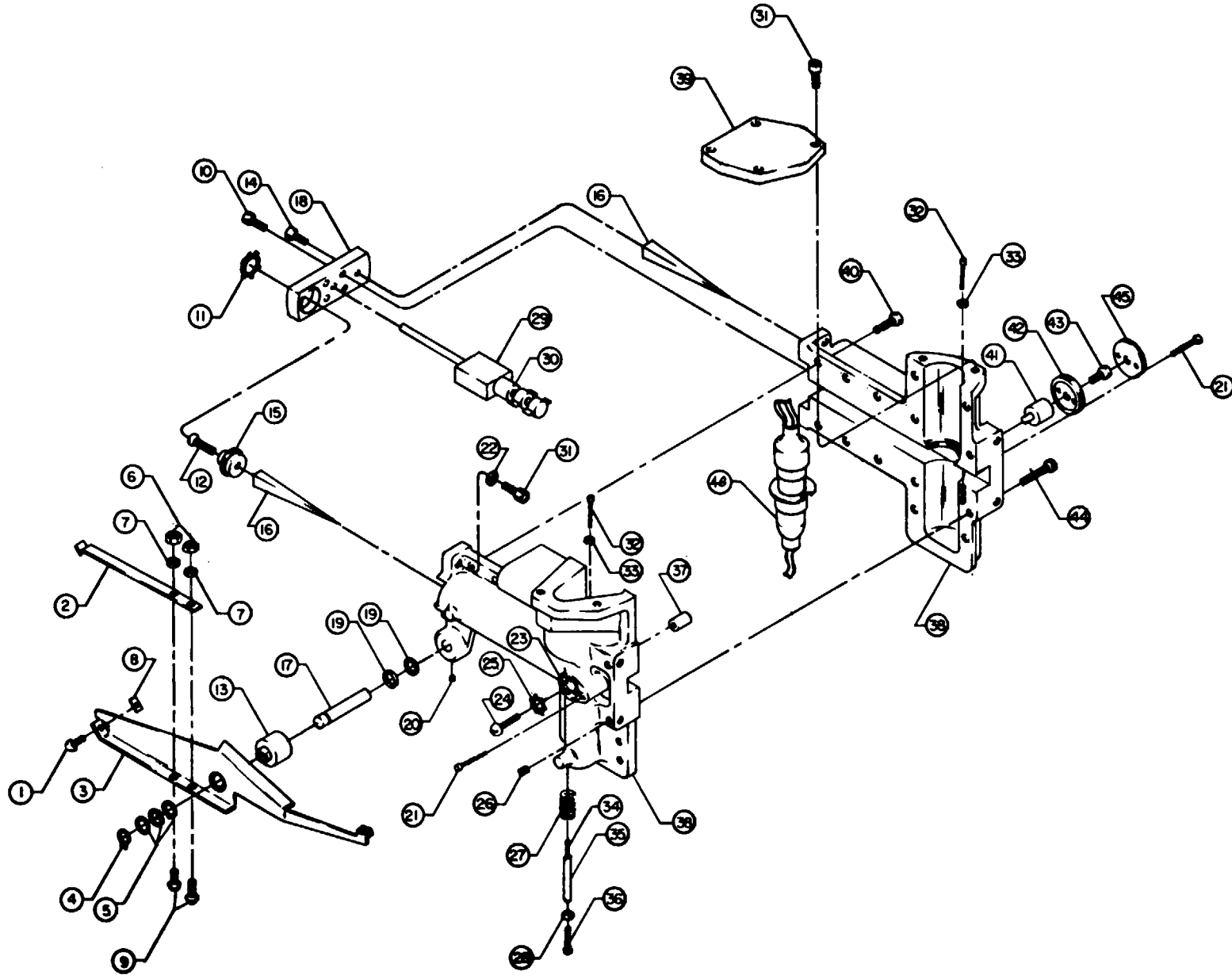

Figure 5. -hp- Model 62A, S. H. F. Signal Generator, Cavity Assembly

REF.	STOCK NO.	DESCRIPTION	QTY.
1	3050-0103	Washer: 9/16 in. o.d. ¼ in. i.d. ss	1
2	628A-32A 4	Shaft: Pinion	1
3	5000-0206	WASHER: Spring 9/16 in. lg	1
4	626A-34B- 1	Tube: Screwdriver	1
5	5020-0233	Collar: ¼ in. shaft ½ in. dia	1
6	3050-0032	Washer: 5/16 in. o.d. 0.190 in. i.d. bras	4 1
7	61B-27	Filter Assembly	
8	3030-0001	Screw: Allen dr set 8-32 thd 3/16 in. lg	2
9	626A-32A- 1	Coupler	1

REF.	STOCK NO.	DESCRIPTION	QTY.
10	2200-0003	Screw: Round head ss 4-40 thd ¼ in. lg	1
11	3030-0016	Screw: Allen head ss 4-40 thd ½ in. lg	8
12	29550-0001	Nut: ½ in. wide 3/8-32 thd br	1
13	2190-0016	Washer: Int lock ½ in. o.d.	1
14	2210-0004	Screw: Flat head ss 4-40 thd ½ in. lg	1
15	626A-32A- 2	Block: End	1
16	626A-32A- 3	Load: Coupler	1
17	0510-0053	Ring: Grip for 3/16 in. shaft	1
18	2420-0001	Nut: 5/16 in. wide ss 6-32 thd w/lock	4

REF.	STOCK NO.	DESCRIPTION	QTY.
19	626A-27A	Filter	1
20	626A-28	Mount: Thermistor	1
21	3030-0013	Screw: Allen dr cap 6-32 thd ¼ in. lg	4
22	628A-24C	Pinion: Power set	1
23	1480-0008	Pin: 1/16 in. dia ½ in. lg	2
24	628A-32A- 6	Shaft: Bevel gear	
25	626A-37B	Shaft	1
26	3030-0060	Screw: Allen head set 2-56 thd	2
27	3030-0007	Screw: Allen dr cap 4-40 thd 1/8 in. lg	2
28	626A-71A	Coupler: Power set	1
29	628A-24D	Gear: Bevel	1

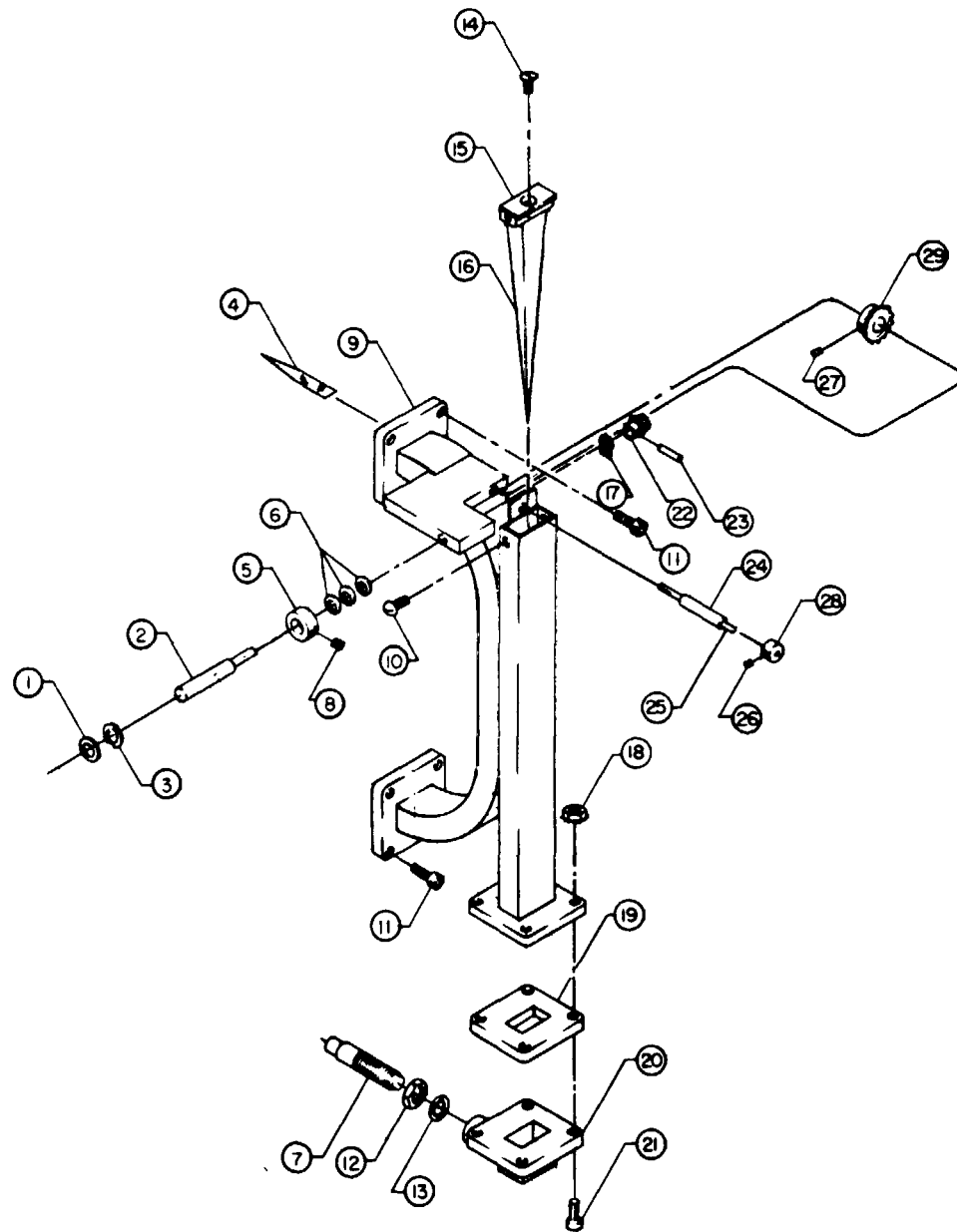

Figure 6. -hp- Model 626A, S.H. F. Signal Generator, Directional Coupler Assembly

REF.	STOCK NO.	DESCRIPTION	QTY.
1	2360-0012	Screw: Round head ss 6-32 thd 7/8 in. lg	4
2	2390-0001	Screw: Bind head ss 6-32 thd ½ in. lg	27
3	2360-0008	Screw: Round head ss 6-32 thd ½ in. lg	12
4	1480-0063	Pin: Dowel ¼ in. lg	2
5	626A-34A-2	Connector 180°	1
6	626A-34A-14	Card: Bent	2
7	2360-0008	Screw: Round head ss 6-32 thd 7/8 in. lg	8
8	2190-0007	Washer: Int lock for #6 screw	8
9	1480-0015	Pin: dowel ¼ in. dia 3/8 in lg	4
10	626A-34A-16	Adapter	2
11	626A-34A-21	Insert: Attenuator	2
12	1410-0021	Bearing: Ball 2-1/4 in. o.d. 1.813 i.d.	4
13	626A-34A-3	Center: Section	2
14	0360-0005	Lug: terminal 11/16 in. lg	4
15	626A-34A-5	Cover: Attenuator	1
16	8160-0009	Braid: R.F. ¼ in. dia alum	A/R
17	1460-0022	Spring: Tension 1/8 in. o.d. 1-½ in. lg	2
18	626A-34A-12	Card: Center	2
19	2460-0001	Screw: Phillips br 6-32 thd ¼ in. lg	2
20	3030-0022	Screw: Allen dr set 6-32 thd 1"8 in. lg	1

REF.	STOCK NO.	DESCRIPTION	QTY.
21	628A-34A-19	Bracket: Flag mounting	1
22	3050-0017	Washer: 3/8 in. o.d. 0.26 i.d. bronze	1
23	628A-34A-28	Ring: Retaining	4
24	628A-34A-6	flag: Assembly	1
25	X382A-5	Shaft: Flag	1
26	X382A-4	Spring: Flag	1
27	2370-0007	Screw: Flat head ss 6-32 thd 1 in. lg	2
28	0361-0032	Eyelet: Flat fl type .084 o.d.	2
29	9300-0015	Spring: Braided nylon 45 lb test	A/R
30	X885-29	Window	1
31	2390-0007	Screw: Bind head ss 6-32 thd 5/16 in. lg	2
32	626A-34A-16	Adapter	2
33	0900-0008	O-Ring: 1.188 i.d. 1.438 o.d.	2
34	3050-0015	Washer: 5/8 in. o.d.	4
35	8160-0008	Braid: R.F. ¼ in. dia alum	A/R
36	3030-0003	Screw: Allen dr cap 6-32 thd 3/8 in. lg	2
37	628A-34A-7	Shaft: Lock	1
38	5020-0233	Collar: ¼ in. shaft ½ in. dia	2
39	5000-0206	Washer: Spring 9/16 in. dia	2
40	628A-34A-11	Dial: Attenuator	1
41	0520-0009	Screw: Flat head ss 2-56 thd ¼ in. lg	2
42	X382A-18	Hub: Dial	1

REF.	STOCK NO.	DESCRIPTION	QTY.
43	3030-0021	Screw: Allen dr set 8-32 thd 3/16 in. lg	2
44	2460-0003	Screw: Phillips br 6-32 thd 5/16 in. lg	2
45	0380-0011	Spacer: ¾ in. lg ¼ in. o.d.	2
46	628A-34A-29	Shield	1
47	2420-0003	Nut: ¼ in. wide 6-32 thd	2
48	2390-0009	Screw: Bind head ss 6-32 thd 3/8 in. lg	2
49	0380-0003	Spacer 1/8 in. lg ¼ in. o.d.	2
50	628A-34A-31	{Pulley Assembly	1
51	626A-34A-4	Housing: Attenuator	1
52	1410-0015	Bearing: Ball 5/8 in. o.d. ¼ in. i.d.	2
53	0510-0005	Ring: Retaining for ¼ in. shaft	2
54	X382A-36	Gear: Stop	1
55	3050-0019	Washer: Brass ½ in o.d. 2 in. i.d.	4
56	J382A-4	End: Section	1
57	5020-0248	Gear: Offset tooth 1.218 in. dia	1
58	2190-0011	Washer: Int lock for #10 screw	1
59	2920-0003	Screw: Round head ss-10-24 thd 5/8 in. lg	1
60	628A-34A-1	Shaft: Worm	1
61	626A-34A-17	Mount: Bearing	2
62	626A-34A-22	Choke: End section	1
63	626A-34A-13	Card: End	2
64	626A-34A-23	End: Section	2

Attenuator Assembly

TM 11-6625-2910-14
Model 626A

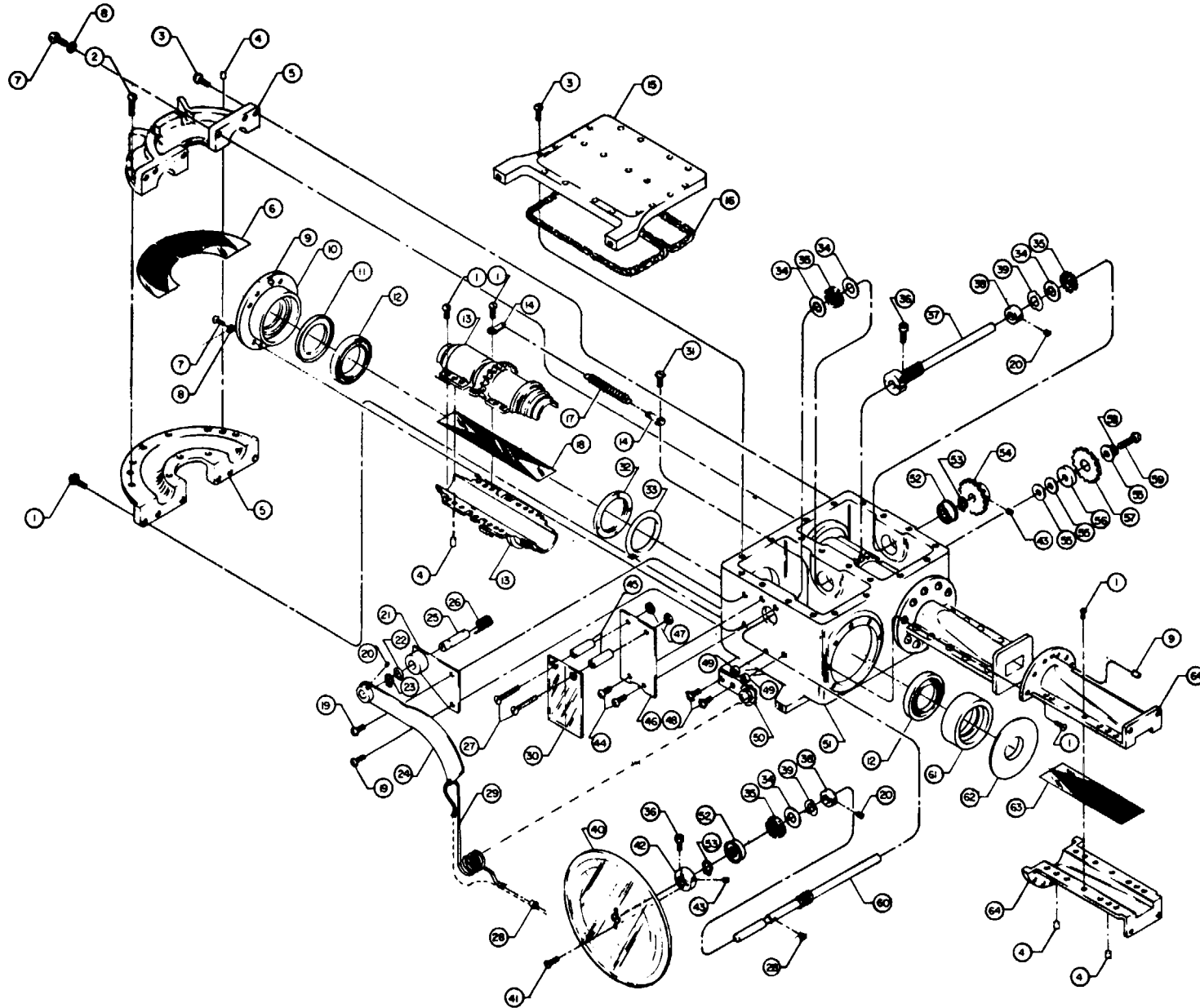

Figure 7. -hp- Model 626A, S. H. F. Signal Generator, Attenuator Assembly

REF.	STOCK NO.	DESCRIPTION	QTY.
1	2990-0001	Screw: Truss head ss 10-24 thd 3/8 in. lg	11
2	2930-0004	Screw: Flat head ss 10-24 thd 1/2 in. lg	3
3	2370-0002	Screw: Flat head ss 6-32 thd 3/8 in. lg	4
4	628A-1AL	Gusset: Left	1
5	2900-0002	Screw: Truss head 10-24 thd 1/2 in. lg	1
6	250-0007	Screw: Bind head ss 8-32 thd 3/8 in. lg	5
7	1251-0026	Connector: Male 8 pin	4
8	2980-0002	Nut: 3/8 in. wide 10-24 thd w/lock	1
9	628A-12N	Bracket	1
10	628A-12G	Bracket	1
11	1200-0005	Socket: Octal tube	4
12	1400-0033	clamp: Tube 1-1/4 in. dia	1
13	626A-65E	board Assy: Voltage regulator	1
14	1400-0032	Clamp: Tube 1-5/8 in. dia	1
15	2420-0001	Nut: 5/16 in. wide ss 6-32 thd w/lock	7
16	12550-0075	Connector: BNC	3

REF.	STOCK NO.	DESCRIPTION	QTY.
17	626A-65D	Attenuator Assy: Power set	1
18	1200-0053	Socket: 7 pin tube printed circuit mtg	11
19	628A-12F	Bracket	1
20	1200-0035	Socket: 11 pin tube	1
21	1200-0008	Socket: 9 pin tube	1
22	3050-0100	Washer: 7/16 in. o.d. 0.147 i.d. brass	2
23	0380-0008	Spacer: 1/2 in. lg 1/4 in. o.d.	2
24	2360-0005	Screw: Round head ss 6-32 thd 3/8 in. lg	2
25	628A-12P	Bracket	1
26	2360-0018	Screw: Round head ss 6-32 thd 1-1/2 in. lg	2
27	628A-1	Chassis	1
28	628A-65D	Board Assy: Circuit	1
29	2190-0005	Washer: Ext lock for #4 screw	2
30	1200-0062	Socket: 9 pin tube mtg printed circuit	4
31	2260-0001	Nut: 1/4 in. wide 4-40 thd ss	2
32	2190-0004	Washer: Int lock for #4 screw	2

REF.	STOCK NO.	DESCRIPTION	QTY.
33	0380-0014	Spacer: 1-3/16 in. lg 1/4 in. o.d.	1
34	3100-0121	Switch: Rotary	1
35	628A-12K	Bracket	1
36	3030-0020	Screw: Allen dr set 8-32 thd 3/16 in. lg	2
37	628A-1AR	Gusset: Right	1
38	2190-0016	Washer: Int lock 0.185 in o.d.	1
39	2950-0001	Nut: 1/2 in. wide 3/8-32 thd br	1
40	55020-0233	Collar	1
41	626A-38A	Wrench: Spanner	1
42	1400-0010	Clip: Fuse 0.406 in. lg x .375 in w	2
43	1400-0011	Clip: Fuse 0.438 in. lg x 0.75 in h -	1
44	1400-0044	Clip	1
45	626A-38B- 1	Screwdriver:	1
46	626A-38B- 2	Wrench	1

Chassis, Front View

TM 11-6625-2910-14
Model 626A

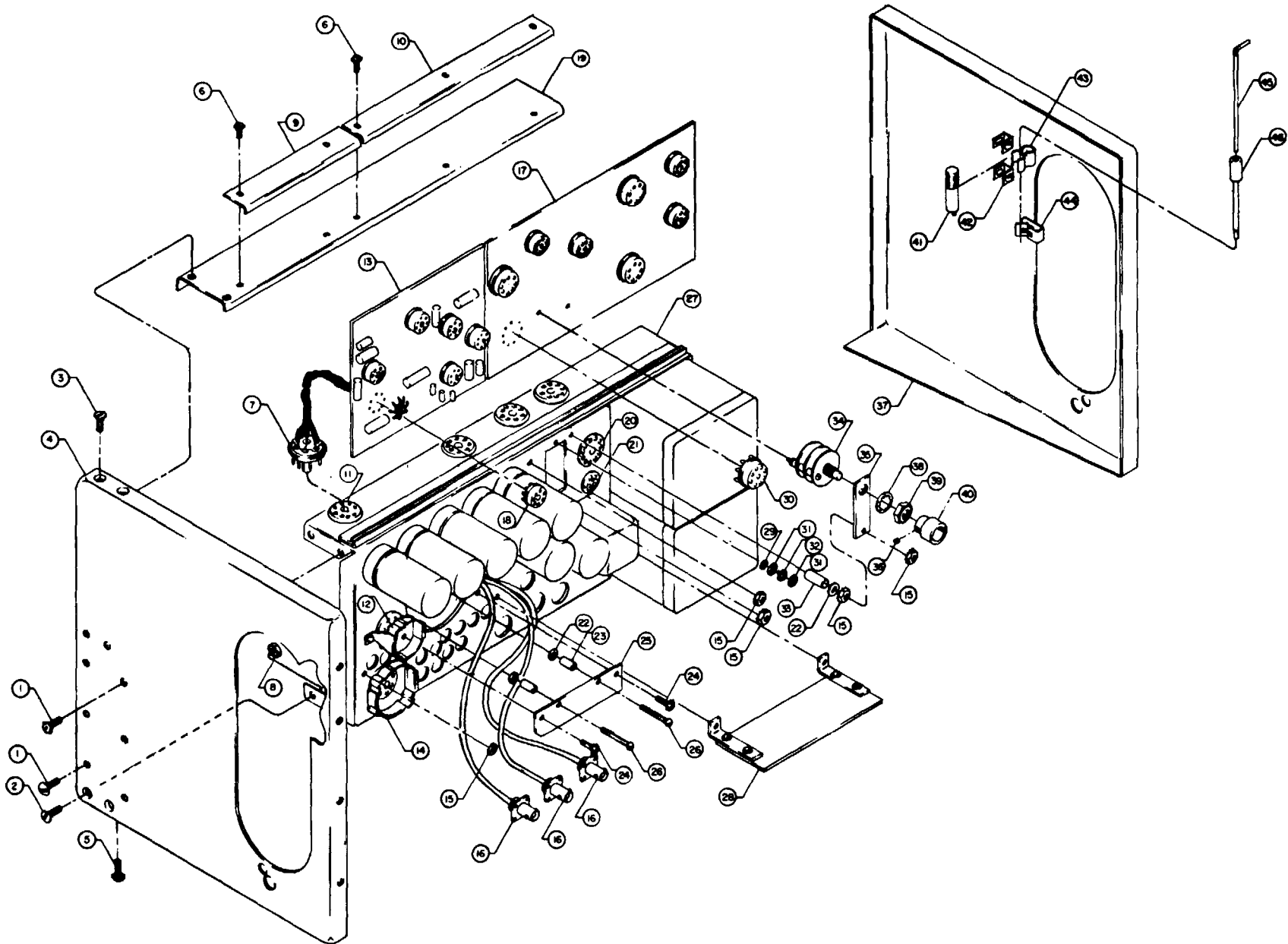

Figure 8. -hp- Model 626A, S.H. F. Signal Generator, Chassis Front View

REF.	STOCK NO.	DESCRIPTION	QTY.
1	628A-1	Chassis	1
2	2190-0034	Washer: Int lock for #4 screw	7
3	2740-0002	Nut: 5/16 in. wide 10-32 thd ss	7
4	1400-0031	Clamp: Cable 3/8 in. dia nylon	1
5	3050-0002	Washer: 7/16 in. o.d. 0.203 in. i.d. steel	1
6	2740-0003	Nut: 3/8 in. Wide 10-32 thd w/lock	1
7	2420-0001	Nut: 5/16 in. Wide ss 6-32 thd w/lock	4

REF.	STOCK NO.	DESCRIPTION	QTY.
8		See Operating and Service Manual	
9	2360-0020	Screw: Round head ss 6-32 thd 2 in. lg	3
10	0360-0012	Strip: 1 terminal	1
11	1200-0005	Socket: Octal tube	6
12	2360-0005	Screw: Round head ss 6-32 thd 3/8 in. lg	2
13	2440-0007	Screw: round head br 6-32 thd 2-1/2 in. lg	2
14	3030-0001	Screw: Allen dr set 8-32 thd 3/16 in. lg	2

REF.	STOCK NO.	DESCRIPTION	QTY.
15	2360-0013	Screw: Round head ss 6-32 thd 1 in. lg	2
16	3160-0012	Fan blade: 4 blades 4.5 in. dia	1
17	0360-00151	Strip: 3 terminal 2 in. 1 gnd	1
18	1520-0001	Plate: Capacitor mtg 1-17/32 x 2-3/16 in.	2
19	2190-0021	Washer: Int lock for #4 screw	5
20	2950-0042	Nut: 1 in. wide 3/4-20 thd br	5

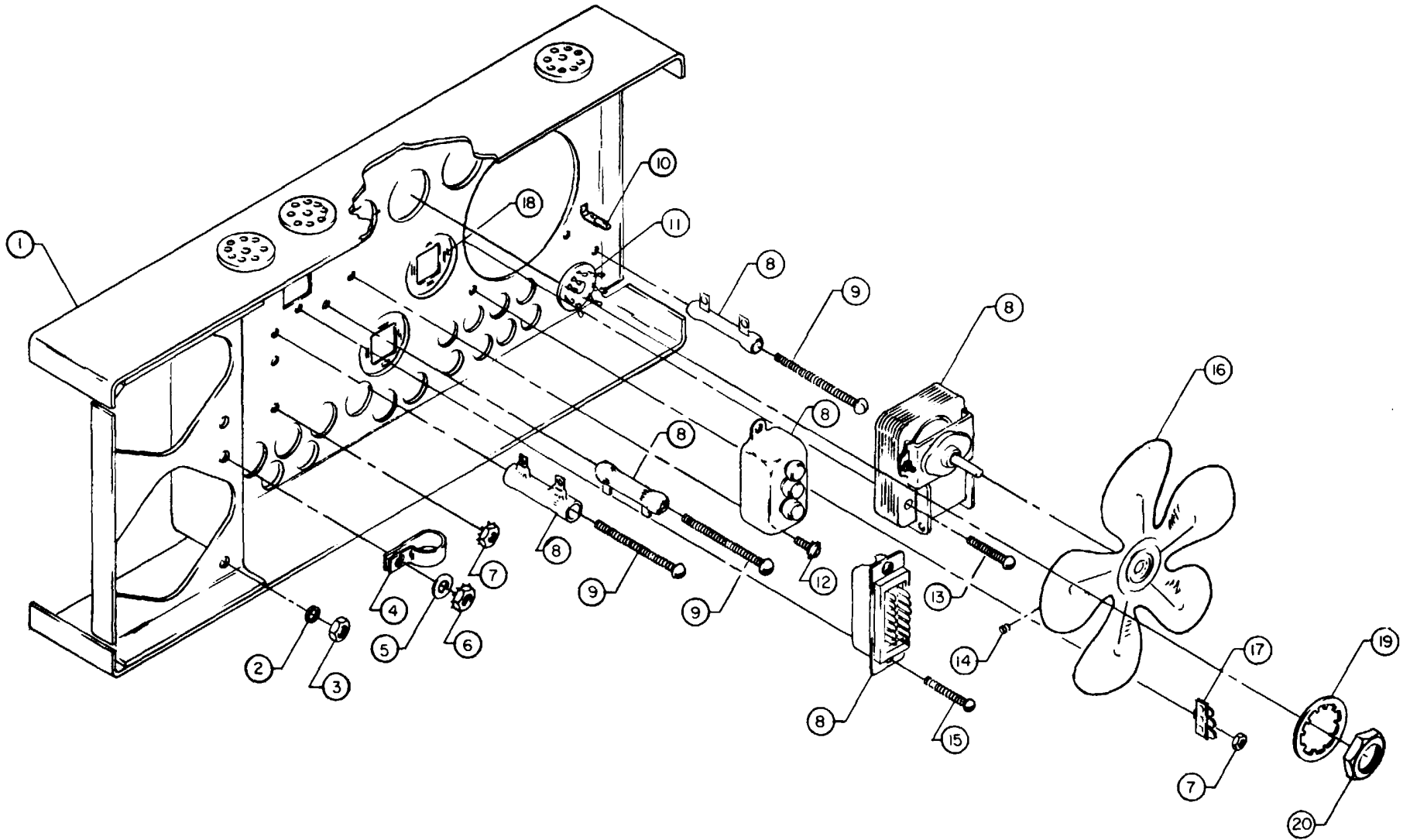

Figure 9. -hp- Model 626A, S.H. F. Signal Generator, Chassis, Rear View

REF.	STOCK NO.	DESCRIPTION	QTY.
1	628A-44A	Dust: Cover	1

REF.	STOCK NO.	DESCRIPTION	QTY.
------	-----------	-------------	------

REF.	STOCK NO.	DESCRIPTION	QTY.
------	-----------	-------------	------

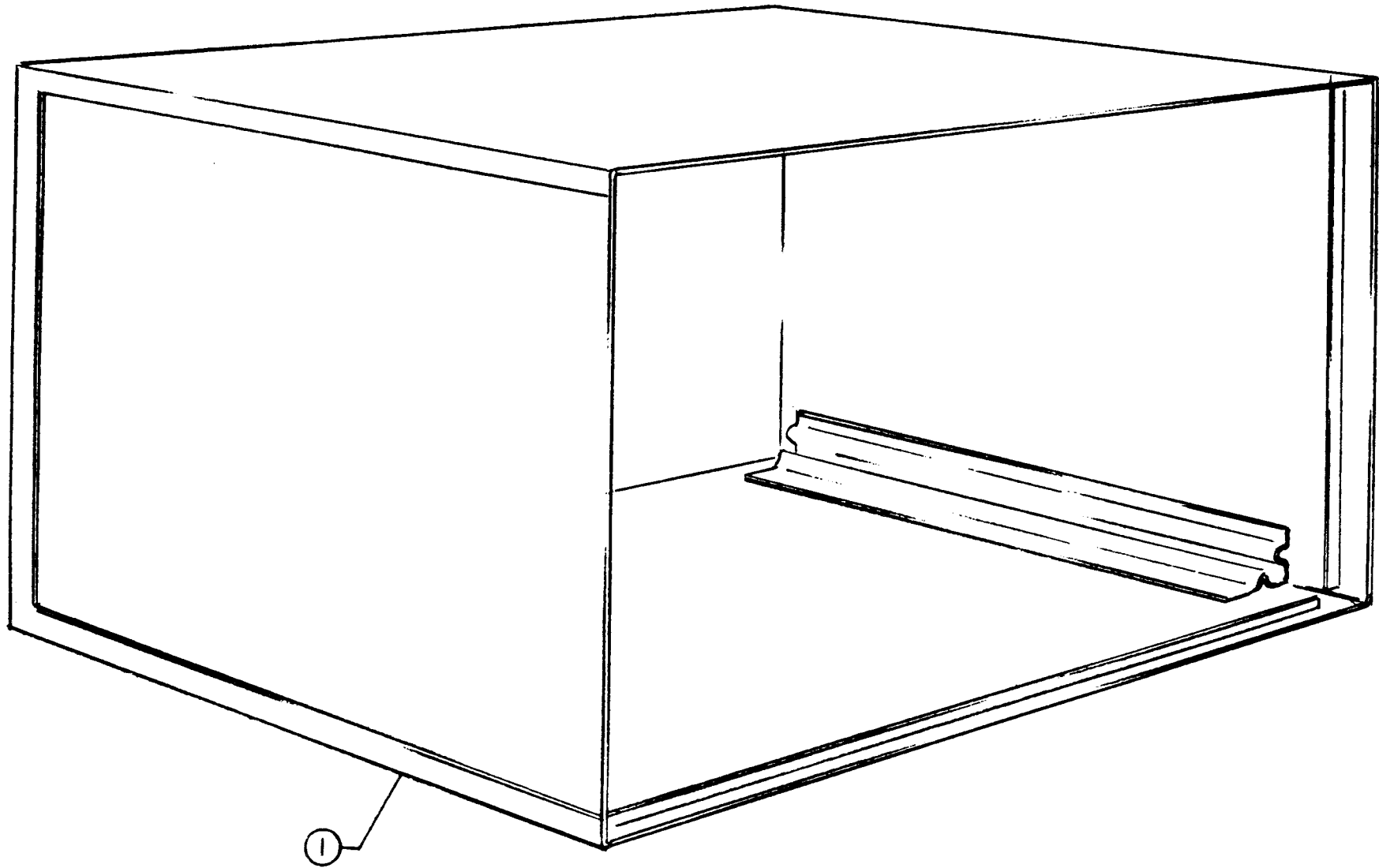

Figure 10. -hp-Model 626A, S. H. F. Signal Generator, Cabinet

By Order of the Secretary of the Army:

BERNARD W. ROGERS
General, United States Army
Chief of Staff

Official:

J. C. PENNINGTON
Brigadier General, United States Army
The Adjutant General

Distribution:

Active Army:

TSG (1)	USAERDAW (1)
USAARENBD (1)	Army Dep (1) except
USAINSCOM (2)	LBAD (10)
TRADOC (2)	TOAD (14)
DARCOM (1)	SHAD (3)
TECOM (2)	USA Dep (1)
OS Maj Comd (2)	Sig Sec USA Dep (1)
USACC (2)	Units org under fol TOE:
HISA (Ft Monmouth) (26)	(1 cy each unit)
Armies (1)	29-134
USASIGS (10)	29-136
Svc Colleges (1)	32-52
Fort Huachuca (5)	32-57
Ft Richardson (CERCOM Ofc) (10)	Units org under fol TOE:
Fort Carson (5)	(2 cys each unit)
Fort Gillem (10)	29-207
WSMR (1)	29-610
USAERDAA (1)	
ARNG & USAR: None	

For explanation of abbreviations used, see AR 310-50.

☆US GOVERNMENT PRINTING OFFICE 1984 0- 445-859

RECOMMENDED CHANGES TO EQUIPMENT TECHNICAL PUBLICATIONS



THEN... JOT DOWN THE DOPE ABOUT IT ON THIS FORM, CAREFULLY TEAR IT OUT, FOLD IT AND DROP IT IN THE MAIL!

SOMETHING WRONG WITH THIS PUBLICATION?

FROM: (PRINT YOUR UNIT'S COMPLETE ADDRESS)

DATE SENT

PUBLICATION NUMBER

PUBLICATION DATE

PUBLICATION TITLE

BE EXACT... PIN-POINT WHERE IT IS

IN THIS SPACE TELL WHAT IS WRONG AND WHAT SHOULD BE DONE ABOUT IT:

PAGE NO.	PARA-GRAPH	FIGURE NO.	TABLE NO.
----------	------------	------------	-----------

TEAR ALONG PERFORATED LINE

PRINTED NAME, GRADE OR TITLE, AND TELEPHONE NUMBER

SIGN HERE:

DA FORM 2028-2 JUL 79

PREVIOUS EDITIONS ARE OBSOLETE.

P.S.—IF YOUR OUTFIT WANTS TO KNOW ABOUT YOUR RECOMMENDATION MAKE A CARBON COPY OF THIS AND GIVE IT TO YOUR HEADQUARTERS.

PIN: 035306-0000